



Broadband Pulsed Infrared Light Sources

- Broadband IR light sources from 2-20 μm
- Consistent Pulsed Operation
- Large Temperature Modulation
- Many Package and Window options
- Evaluation Kit for Rapid Prototyping
- Highly stable
- Long life







FLIR ICx Photonics offers a unique class of electrically pulsed, high intensity infrared radiators for gas analysis, spectroscopy, calibration and tactical identify friend or foe (IFF) applications. These radiators feature a low thermal-mass filament tailored for high emissivity. The filament is fabricated using a patented process such that it supplies bright IR power output while operating much cooler than alternatives. This lower temperature operation reduces the chance of igniting combustible gasses, improves power efficiency, reduces heating of the optics and detectors, and prevents illumination in the SWIR bands. These IR sources are typically pulsed at rates from $\frac{1}{2}$ to 10 Hz with several hundred degrees of temperature modulation.

For demonstration and system design, FLIR provides an Evaluation Kit that includes the light source of your choosing. The Evaluation Kit drive card produces a flat-topped current pulse of adjustable amplitude, length, and frequency that can be run with the pre-programmed settings, or can be connected to a PC for user control via included Windows[™] software.

The table below provides the specifications for each of our broadband IR light sources. If you do not see a product that meets your criteria, please contact us as we may be able to provide a custom solution that meets your needs. Also, we have a line of narrowband IR light sources which use MEMS technology. Because of their spectral tuning, these are extremely efficient devices suitable for battery powered applications. Please see datasheet: TunIR 3-5 and 8-12.

These emitters are end of life. Remaining inventory at Boston Electronics is shown in red. Limited quantities remain in stock as of 7/8/18.

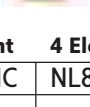
SPECIFICATIONS, PART NUMBERS, and WINDOW OPTIONS:

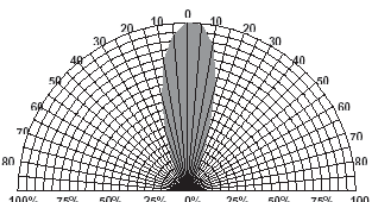
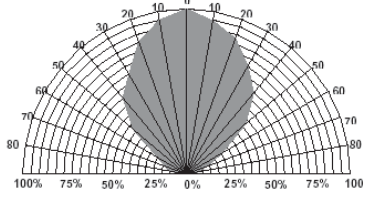
	Parabola	TO-8	Multi-Element		TO-5	TO-46
						
Windowless	reflectIR-P1N	NL8LNC	NL82LNC	NL84LNC	NL5LNC	NL46LNX
Sapphire 2 to 5.25 μm	reflectIR-P1S	NM8ASC	NM82ASC	NM84ASC	NM5NSC	N/A
Germanium 7 to 12 μm	N/A	N/A	n/a	n/a	NL5NGC	N/A
Calcium Flouride 2 to 9.5 μm	reflectIR-P1C	NL8ACC	NL82ACC	NL84ACC	NL5NCC	N/A
Rated Temperature	750 °C					
Minimum Resistance	1.4 Ohms	2.8	1.3 per Element		2.5	0.4
Maximum Resistance	2.0 Ohms	4.5	1.7 per Element		3.7	1.0
Maximum Input Power	1.7 W	2.2 W	1.6 W per Element		2.0 W	1.1 W
Modulation Speed	Constant - 30HZ; 100% modulation <5hz					
Output Radiation Pattern*	<p>30 degrees</p> 		<p>95 degrees</p> 			
<p>* Full angle for 50% of peak power</p>						

Custom variations and tighter specification versions are also available.

PULSED OPERATION

Although capable of running at duty cycles of up to 100 % (DC) most users run the filaments with duty cycles of less than 50%. Square-waveform constant current or constant voltage drive schemes are the simplest and most cost effective means of powering the sources. For constant current drives, the power delivered to the source

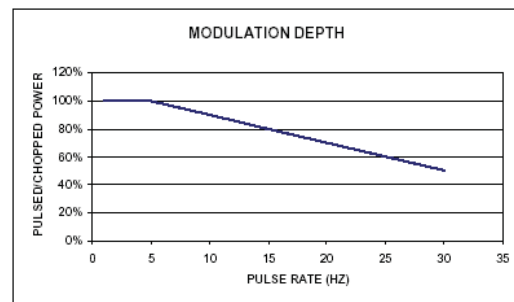

goes as $I^2 \times R$. As the source heats up, its resistance increases slightly, causing the power delivered to the source to increase during the "ON" portion of a pulse. For constant voltage drives, delivered power goes as V^2/R ; therefore the power delivered to the source tends to decrease slightly during the length of a pulse. Other drive schemes can also be employed; constant power or DC for example.

Owing to the extremely low thermal mass of pulsIR emitters, shot-to-shot stability is directly related to drive circuit stability. Variations in drive pulses will translate into variations in output. To determine this we used a liquid nitrogen cooled InSb detector available in our laboratory for detecting energy in the 2-5 μm range. The pulsIR source was driven with a constant-voltage drive circuit that ensures pulse-to-pulse repeatability (standard deviation) of 5.3×10^{-4} . Measurements of the InSb detector reading from 16 seconds of 10 Hz operation was measured to have a comparable standard deviation of 6.8×10^{-4} .

SOURCE LIFETIME

The following graph shows the results (to date) from an ongoing extended life test experiment using an ICx Photonics NM8ASC source. The source is being driven by a constant current drive board at 1 Hz, 30% duty cycle at an approximate temperature of 650°C. Two pyroelectric detectors are monitoring the source output at two distinct wavelengths. In the following chart, the circles show the source output at 4.29 microns (CO_2) while the diamonds show the output at 3.9 microns (reference). The detectors are mounted about four inches from the front face of the source and a dry nitrogen purge is used to prevent water vapor and carbon dioxide in the lab air from affecting the measurement. The temperature in the lab is not very well controlled however, and much of the variation (specifically the bump at ~2000 hours) is due to room temperature swings.

The definition of failure, and thus the definition of lifetime, is very subjective as each system has unique sensitivity to drift (largely related to the A/D bandwidth). We have encountered several applications which define failure as >15% drift from the original power level, so we will adopt this definition for the purposes of this computation. The graph below shows that the median signal level from the 3.9 and 4.29 μm detectors is roughly 4 volts; the linear regression fits to the raw data indicate that both of

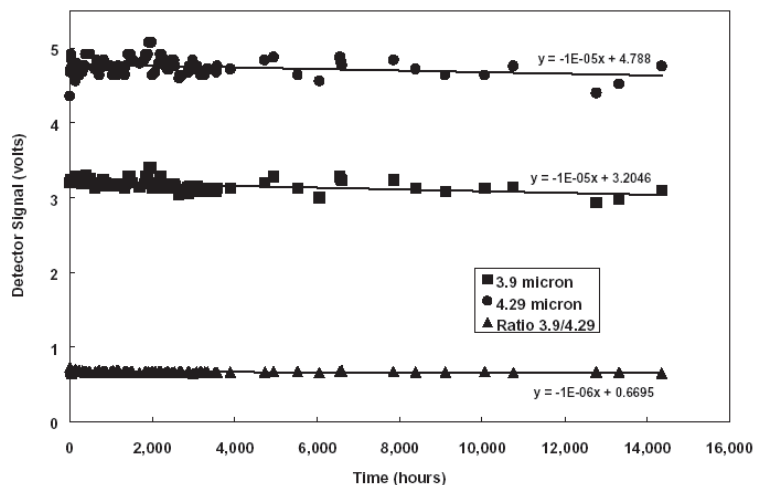

these signals are decreasing at a rate of 1×10^{-5} volts/hour. With our assumed signal drift tolerance of 15% and 4 volt signal level, we require a 0.6 volt signal change to signal failure of the light source $[0.15 \times 4]$. With our measured rate of change being 1×10^{-5} volts/hour it will take approximately **7 years** of continuous operation to obtain a 15% signal change $[(0.6v)/(1 \times 10^{-5}v/hr)/(8760hrs/yr)]$. Since many systems utilize the ratio of the gas measurement to a reference, they are sensitive not to signal changes, but to change in the ratio of the two signals. With a measured slope of 1×10^{-6} volts/hour and a 0.75 volt signal the same computation yields a lifetime of **13 years**. Since all of the known filament degradation mechanisms are temperature dependent, the time to 15% failure is strongly dependent upon operating temperature or electrical power applied. Therefore, caution should be used in extrapolating these results to your application.

REFLECTIR PACKAGE DIMENSIONS

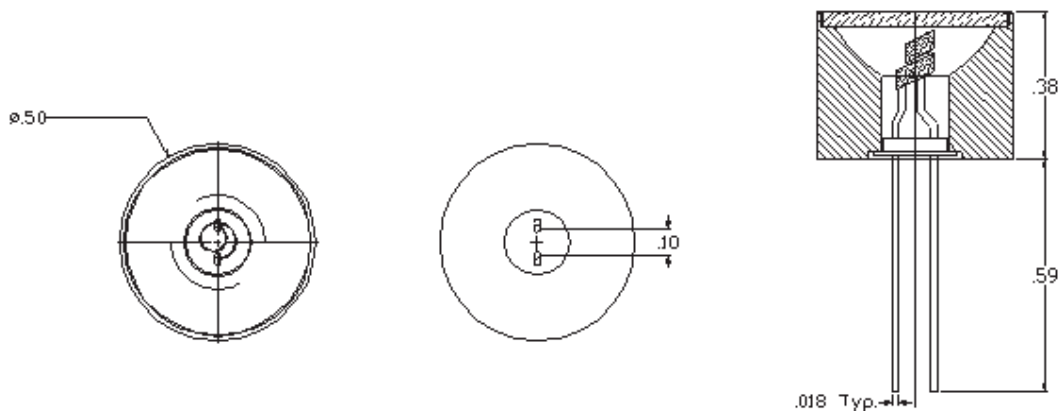

TO-8 PACKAGE DIMENSIONS

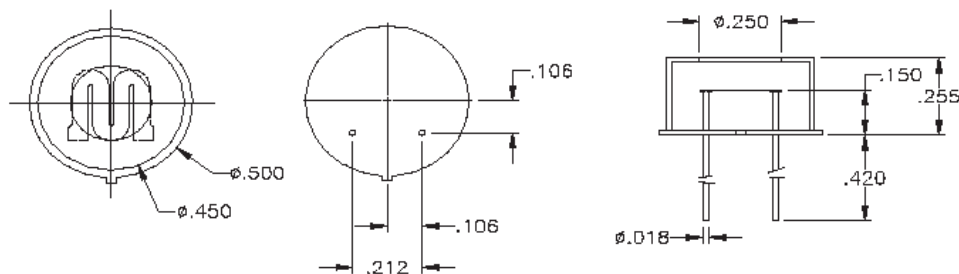

MULTI-ELEMENT PACKAGE DIMENSIONS

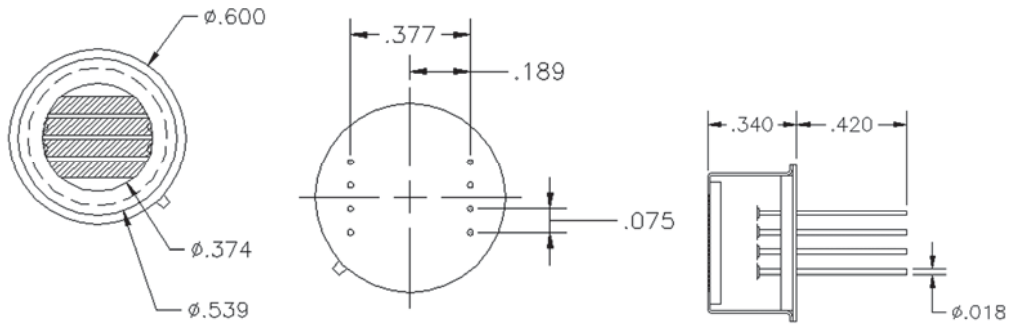

TO-5 PACKAGE DIMENSIONS

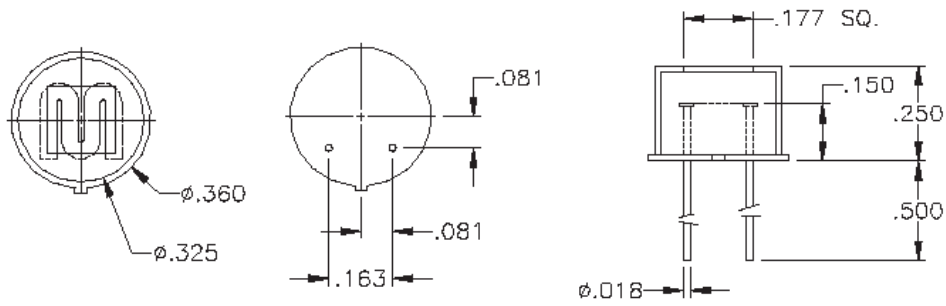

TO-46 PACKAGE DIMENSIONS

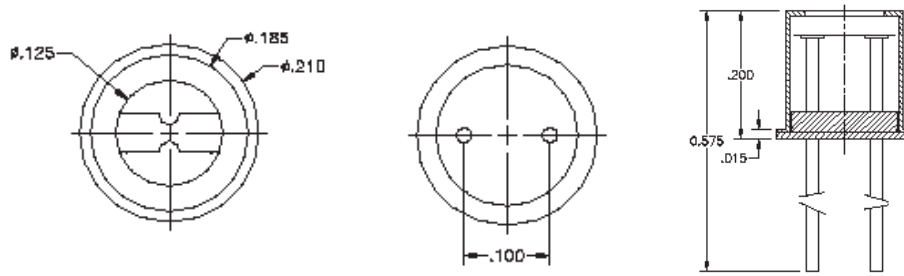

reflectIR - P1N

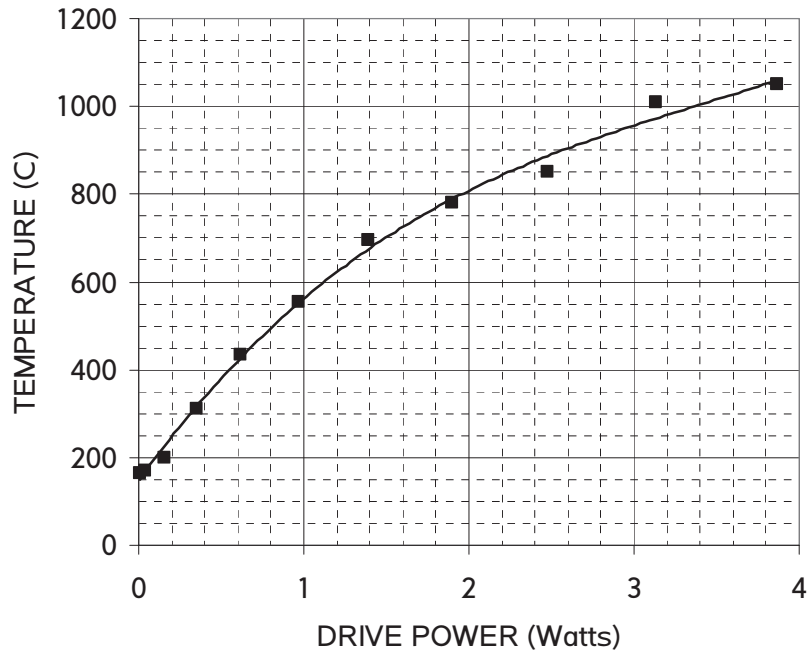

NL8LNC

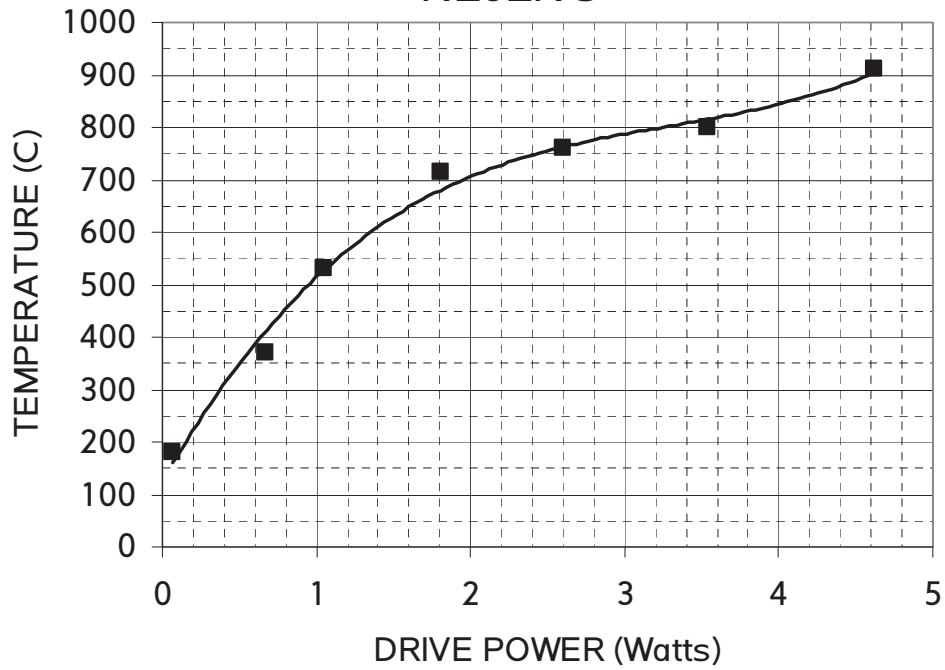

NL5LNC

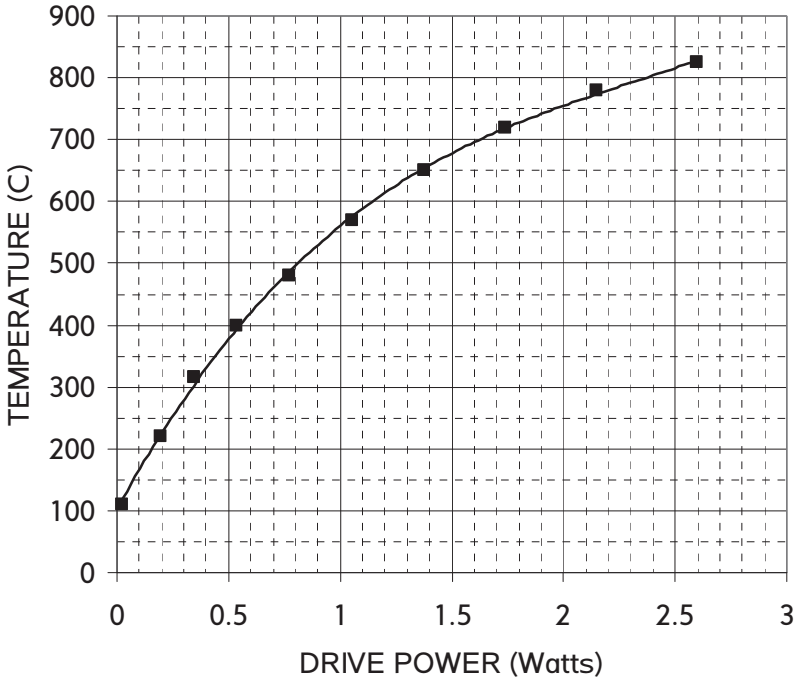

NL46LNX

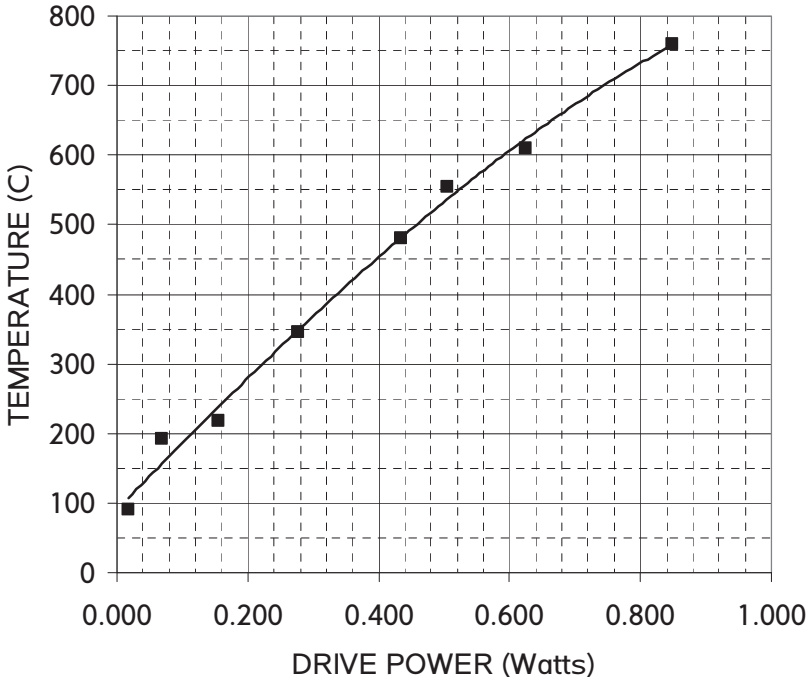

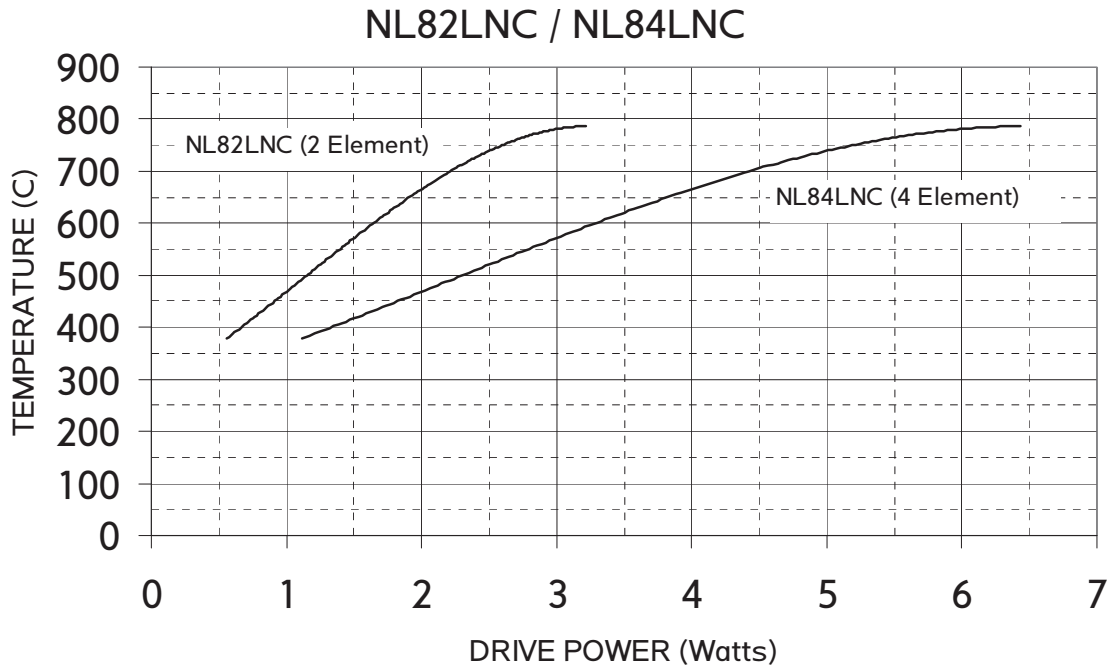

(617)566-3821; fax (617)731-0935; irsource@boselec.com