

Room Temperature Tunable Quantum Cascade IR Lasers

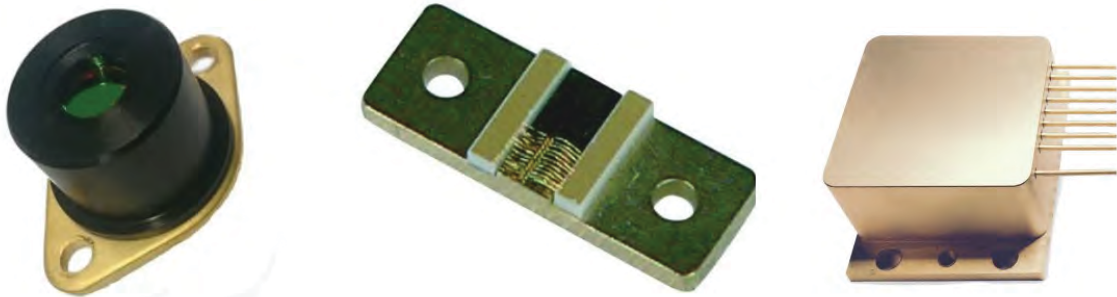

Readily available CW and Pulsed:

- Single Mode DFBs – devices between 4.2 – 16.6 μm
- Fabry-Perot – suitable for external cavity use including devices EC-tunable over 300cm^{-1}
- Built to order: $\sim 4 - >200 \mu\text{m}$

Alpes #sb9 at different temps with different drive voltages

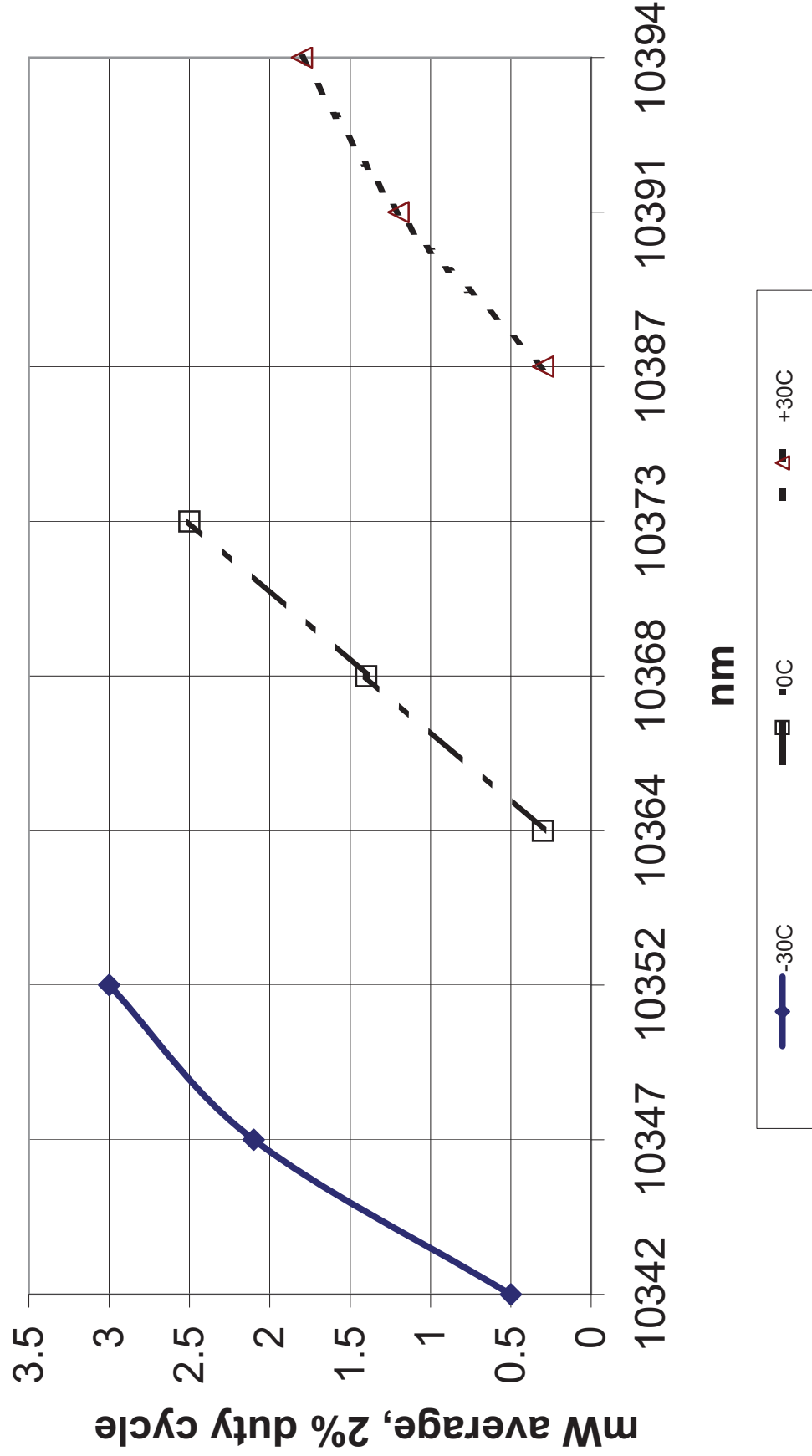

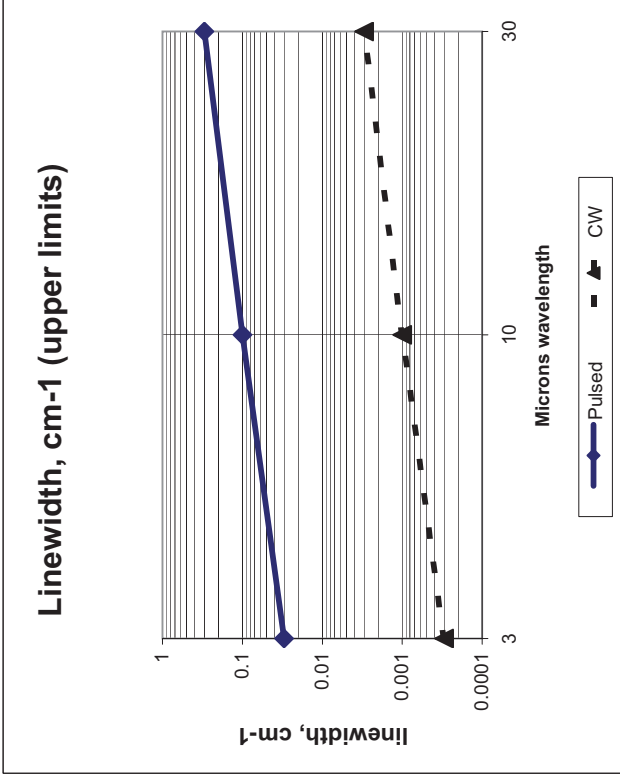
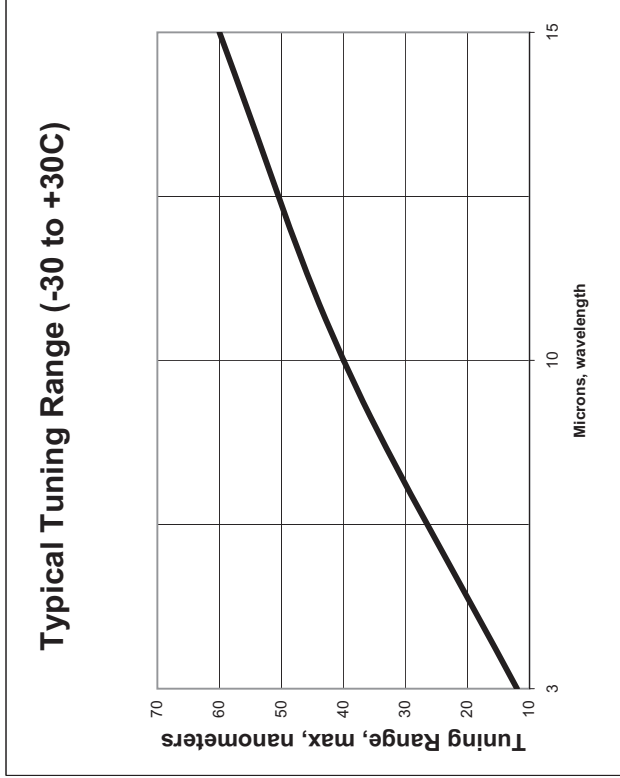
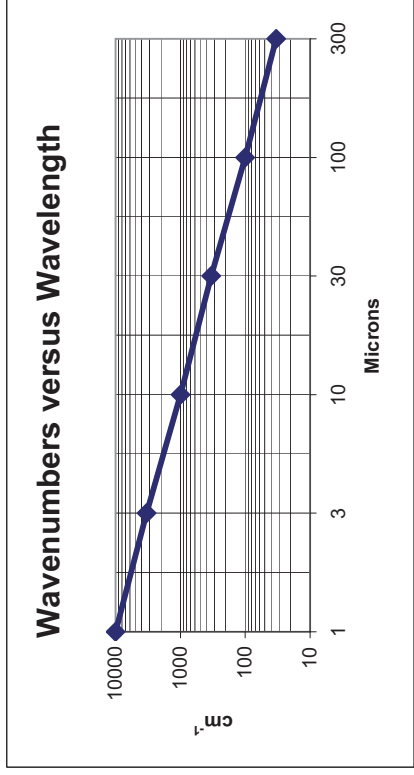
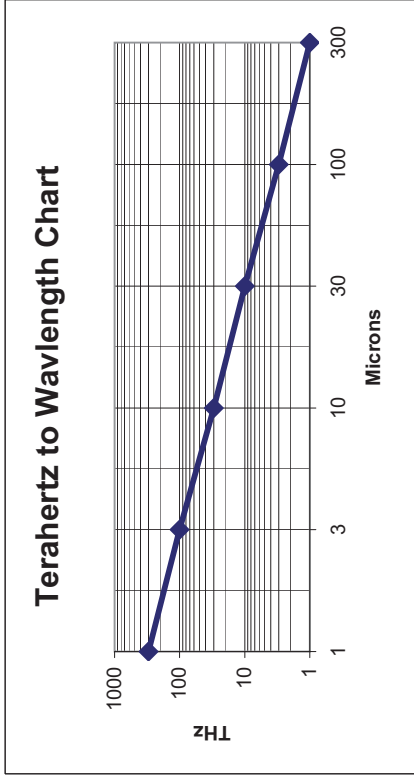

Some useful numbers and some typical results.

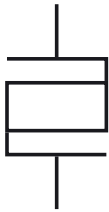

High Power Sources

Alpes Lasers introduces its new high power sources. These Quantum Cascade Lasers have a minimum average power of 1W and more than 9W of peak power. Available in a collimated HHL package with a dedicated driver, these lasers can be used for free-space optical communications, energy deposition, illumination and IR countermeasures.

Electro-optical Characteristics

QUANTITY	ACRONYM	MIN	TYP.	MAX	UNIT	NOTE
Min. average power	MAP	1.0	1.2	1.5	W	1
Peak power	PP	1	3.0	9.0	W	2
Output spectrum	-	-	MM	-	-	3
Spectral width	SW	50	100	150	cm ⁻¹	
Duty cycle	DC	0	30	100	%	4
Central wavelength	CWL	2300	2040	1500	cm ⁻¹	5
Wall-plug efficiency	WPE	10	-	-	%	6
Beam quality	M ²	1.5	2.0	3.0	-	7
Divergence	MD	-	-	6	mrاد	8
Pointing error	MPE	-	-	6	mrاد	8
Pulse width	PW	20	200	CW	ns	9
Beam diameter	BD	-	4	-	mm	10
Rise/fall time requirements	RFT	-	10	15	ns	11
	Packaging	HHL	-	-	-	12
Package size LxWxH		33x45x19			mm ³	12
TEC current	TECI	1.5	2.0	3.0	A	13
TEC voltage	TECV	9.0	12.0	18.0	V	13
Heatsink cooling capacity		25	35	65	W	
	Driver	-	S-2	-	-	14
Pulse width	PW	30	200	CW	ns	15
Rise/fall time	RFT	5	6	8	ns	16
Package & driver size LxWxH		135x45x22			mm ³	17
Lead time		6	8	26	weeks	18

Key features

- High power
- Collimated source
- High beam quality
- Multi-mode spectrum
- Swiss made

Key benefits

- Free-space optical communication
- Energy deposition
- Illumination
- IR countermeasures



CLASS 4 LASER PRODUCT

The typical data are taken with 2040 cm⁻¹ laser with typical Peltier current (TECI) cooling with 20°C water cooled heatsink. These specifications may be changed without further notice.

- This power is attained in pulse mode with about 30% DC. Lower and higher DC operation of the device may exhibit slightly less average power.
- The typical PP is obtained in the max power conditions i.e. 30% DC. The PP reaches its lowest value for CW operation and is maximum at lower DC but does not reach higher than max value even for extremely low DC. It is to be noted that this is also the case for very short pulses, the absolute max ratings for the laser current given in the device datasheet may not be exceeded even for short period of time.
- The output spectrum is Multi Mode (MM). This comes from the existence of several modes in the longitudinal direction, however there is only one mode in the lateral direction.
- The device may operate up to Continuous Wave condition (CW) but its maximum average power output is attained around the typical DC conditions.
- The presently available devices are centered around 2040 cm⁻¹, devices ranging from min to max indicated value may be ordered with up to 26 weeks lead-time, please inquire and will be available off stock within 2015.
- This value is obtained at max power conditions.
- Standard value, this specification may be tightened on request.
- Is defined as the FWHM along the fast axis.
- 200 ns is optimum as it provides a good compromise between the time taken to start and stop laser operation where heat is dissipated mostly uselessly and the heating occurring during laser operation. Deviations to this pulse length will thus reduce overall emission performances.
- Measured at the window of the HHL.
- Using longer rise or fall time may impair the performances of the laser by overheating the device in conditions where it cannot emit light thus losing efficiency and output power.
- Overall dimensions, excluding 20 mm pins. Other configurations may be adapted, please inquire.
- The typical values are obtained in nominal conditions, deviations to these conditions towards cooler environment will reduce the cooling requirement and increase them for higher temperature conditions. A heat dissipation capacity of 10 W/K is recommended to ensure the heatsink temperature does not degrade significantly the cooling capacity.
- The device is not yet on the shelf but will be introduced Q2 2015
- Values at 80% of the amplitude. The device is capable of addressing arbitrary modulation patterns required by your applications. The patterns may be programmed in the driver or supplied from a logic control.
- Values for 20% to 80% of the amplitude. The RFT cannot be set but the shorter being the better, it suits well the laser needs.
- The driver must be screwed directly to the HHL pins to reduce the pulse transmission length. The performances are not guaranteed if the driver is not attached directly to the HHL.
- Leadtime for other Central Wavelength than 2040 cm⁻¹ up to 26 weeks, please inquire.

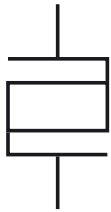

High Power Sources

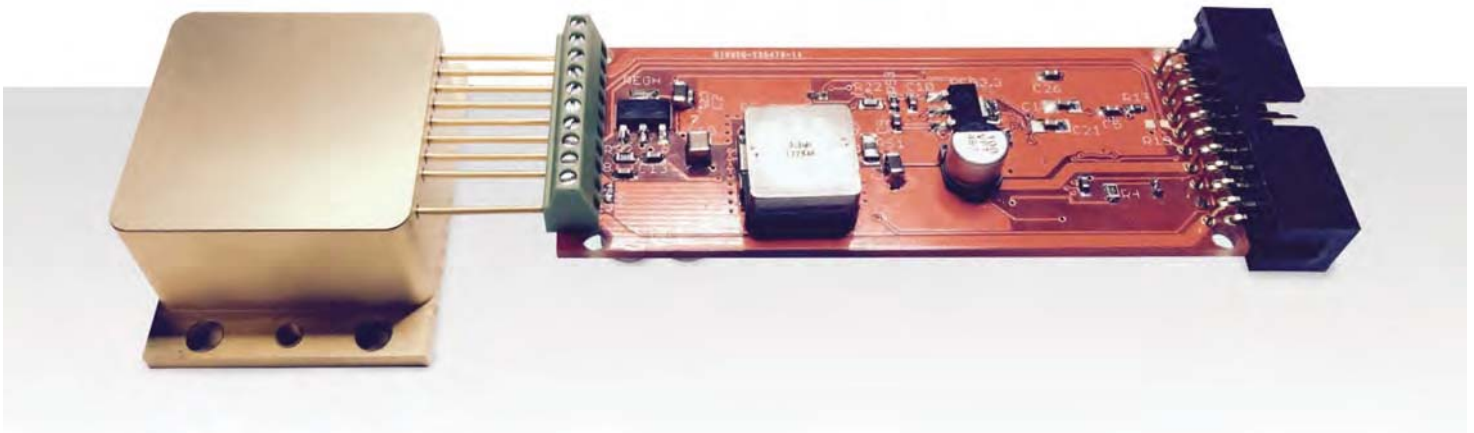

Currently available
at 4.9 μm

—
other wavelengths
available soon!

Pulse sequence can be
programmed internally
or externally controlled
through TTL signals.

—
Overcurrent and overheating protection included.
Temperature controller not included.

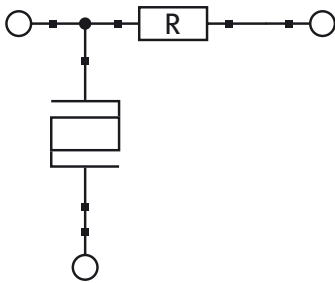

Extended Tuning DFB Source

Alpes Lasers introduces a new class of Extended Tuning DFB, the QC-ET. These QC-ET use a dual current control to extend the mode-hop free tuning to more than 0.4% of the central wavelength ($>6 \text{ cm}^{-1}$ at 1270 cm^{-1}). While the first laser input allows direct intensity modulation in the same manner as standard DFB lasers, the integrated heater current I_T allows to offset the wavelength much faster than the temperature change of the heatsink temperature would do.

Electro-optical Characteristics

QUANTITY	ACRONYM	MIN	TYP.	MAX	UNIT	NOTE
Average power	P	1	–	100	mW	1
Min power tuning range	MPTR	5	6.5	10	cm^{-1}	2
Duty cycle	DC	0	100	100	%	3
Central wavelength	CWL	2325	1270	900	cm^{-1}	4
Laser current	I_L	50	400	600	mA	5
Tuning current	I_T	0	600	1000	mA	6
[Laser] Operation Temperature	T_{opt}	0	10	30	C	7
Operation Temperature	T_{op}	-55	15	30	C	8
Max tuning range @ 1kHz	T-1kHz	3	4	5	cm^{-1}	9
Max tuning range @ 10kHz	T-10kHz	1.5	2	2.5	cm^{-1}	10
Max tuning range @ 100kHz	T-100kHz	0.2	0.4	0.6	cm^{-1}	11
Electrical tuning bandwidth	ETB	2	5	10	kHz	12
Full tuning range	FTR	5	10	15	cm^{-1}	13
Full relative tuning range	FRTR	0.4	0.8	1.2	%	14
	Packaging HHL	–	–	–	–	15
Package size LxWxH		33x45x19			mm^3	15
TEC current	TECI	1.5	2.0	3.0	A	16
TEC voltage	TECV	9.0	12.0	18.0	V	16
Heatsink cooling capacity	–	25	35	65	W	

Key features

- Wavelength and power independent control
- Standard DFB tuning
- Extended tuning at constant heat-sink temperature

Key benefits

- Increased wavelength scanning span fully electrically (Increased electrical wavelength scan)
- Wavelength dither and ramps as in conventional DFB
- DFB wavelength reproducibility
- DFB linewidth and noise



CLASS 3B LASER PRODUCT

Data presented are valid across the spectral range where QC lasers can be manufactured and the typical values are given for a 1275 cm^{-1} laser. These specifications may be changed without further notice.

- Power varies due to the simultaneous change in laser current and wavelength control current necessary to access the full tuning range.
- The MPTR is defined as the attainable wavelength range in which the minimal power of 1 mW is obtained.
- The devices typically operate CW but any type of Laser current modulation is possible within the maximum ratings.
- The extended tuning technology can be applied at any QCL attainable wavelength, please enquire for the lead-time of your wavelength of choice. Presently devices at 1275 cm^{-1} are available at the indicated lead-time.
- The laser current is not changed compared to conventional DFB lasers.
- The electrical tuning current acts as a heat-sink heater control, any current below the max can be used.
- The laser operation temperature may be limited if the heatsinking conditions provided to the package are not sufficient. Higher temperatures are possible but the tuning range may be reduced.
- Operation at higher heat-sink temperatures may cause reduced laser performances.
- The T-1kHz is measured at constant laser current and with a heater modulation of 1 kHz and are given for a 1275 cm^{-1} laser.
- The T-10 kHz is measured at constant laser current and with a heater modulation of 10 kHz and are given for a 1275 cm^{-1} laser.
- The T-100 kHz is measured at constant laser current and with a heater modulation of 100 kHz and are given for a 1275 cm^{-1} laser.
- The ETB is the frequency at which the FM modulation obtained by the electrical tuning is reduced by 3dB.
- From the onset of lasing at Top to the wavelength at max Laser (I_L) and max Tuner (I_T) current. This quantity strongly depends on wavelength as the tuning factor is proportional to the central wavelength. The values here are given for a device at 1275 cm^{-1} .
- The FRTR provides the proportionality between the FTR and the CWL with $\text{FRTR} = \text{CWL} \cdot \text{FTR}$. This value varies for individual devices according to min max specifications.
- Overall dimensions, excluding 20 mm pins. Other configurations may be adapted, please enquire.
- The typical values are obtained in nominal conditions, deviations to these conditions towards cooler environment will reduce the cooling requirement and increase them for higher temperature conditions. A heat dissipation capacity of 10 W/K is recommended to ensure the heatsink temperature does not degrade significantly the cooling capacity.

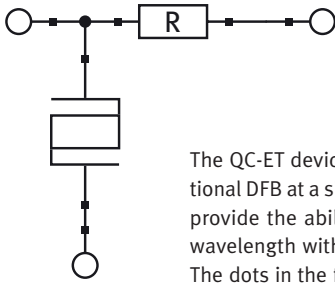

Extended Tuning DFB Source

The QC-ET devices provide a larger tuning than a conventional DFB at a single heat-sink temperature. These devices provide the ability to tune fully electrically the emission wavelength without changing the heat-sink temperature. The dots in the figure show the power at a given emission wavelength and heat-sink temperature for the device used as a conventional DFB i.e. without wavelength current tuning I_T . The shadowed area shows the attainable wavelength and power region for various tuner current (I_T). This area is attainable without changing the heat-sink temperature, widely increasing the speed at which a region of the spectrum may be scanned. Using proper ramps for the laser and tuner current the whole region may be explored at once with speeds in the 100 Hz to kHz range.

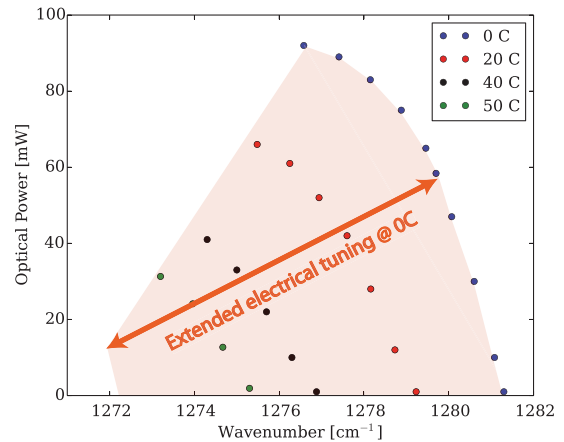

Example of wide scanning of a N_2O gas cell, with fast I_T scans and independent I_T values.

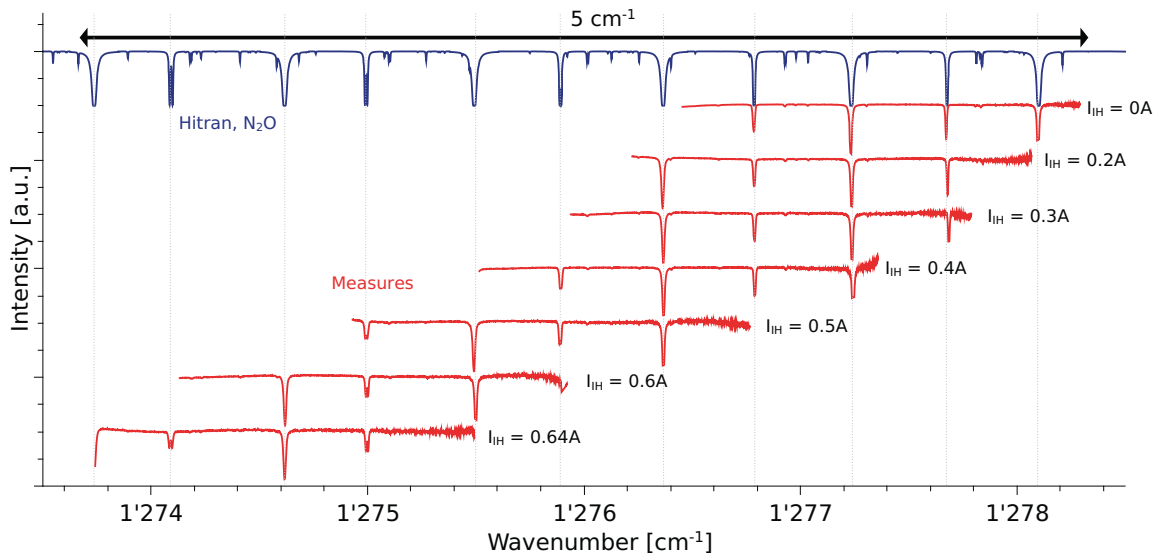

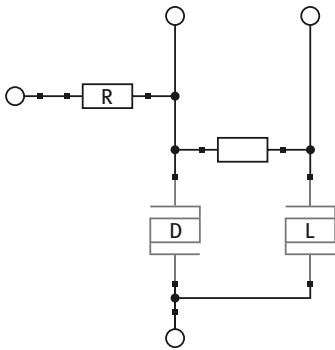

Extended tuning DFB-QCL AM/FM modulator

Alpes Lasers introduces a new class of extended tuning DFB quantum cascade lasers (QC-ET) with AM/FM modulator. Contrarily to standard DFB lasers, these lasers use independent inputs to control the wavelength and amplitude of the emitted light, enabling true AM and FM modulation with minimal cross-talk.

Electro-optical Characteristics

QUANTITY	ACRONYM	MIN	TYP.	MAX	UNIT	NOTE
Average power	P	1	10	-	mW	1
Min power tuning range	MPTR	5	6.5	10	cm ⁻¹	2
Duty cycle	DC	0	-	100	%	3
Central wavelength	CWL	900	1275	2500	cm ⁻¹	4
FM modulation BW	FMB	1	2	5	kHz	5
AM crosstalk	AMC	-	-13	-10	dB	6
AM modulation BW	AMB	8	10	-	MHz	7
FM crosstalk	FMC	-	-	0.05	cm ⁻¹	8
Packaging	HHL	-	-	-	-	9
Operation temperature	T _{op}	-55	15	30	°C	10
[Laser] Operation temperature	T _{opt}	0	10	50	°C	11
TEC current	TECI	0	1	2.5	A	12
TEC Voltage	TECV	0	5	11	V	12
Heatsink cooling capacity		25	35	65	W	
Package size LxWxH		33x45x19			mm ³	13
Lead time		6	8	26	weeks	14

Key features

- Wavelength and power independent control
- Standard DFB tuning
- Extended tuning at constant heat-sink temperature
- Additional separate power control
- Cross-talk compensation

Key benefits

- Increased wavelength scanning span fully electrically (Increased electrical tuning)
- Wavelength dither and ramps as in conventional DFB
- DFB wavelength reproducibility
- DFB linewidth and noise
- Pure AM & FM modulation



CLASS 3B LASER PRODUCT

Data presented are valid across the spectral range where QC lasers can be manufactured and the typical values are given for a 1275 cm⁻¹ laser. These specifications may be changed without further notice.

1. Measured in CW operation
2. Within the MPTR the max power may not be achieved but only a min power of 1mW.
3. Operation is typically CW but pulsed operation is possible however single mode operation may not be guaranteed for short pulses or at the beginning of the pulse i.e. the first 100 ns.
4. Off the shelf wavelength is 1270 cm⁻¹, up to 6 month lead time may required for other wavelength.
5. 3 dB cut off frequency.
6. dB ratio of the residual amplitude modulation with 1 cm⁻¹ Peak to Peak FM modulation amplitude.
7. 3 dB cut off frequency
8. Wavelength change when the amplifier current is modified and the seed current stable (i.e. cross-talk).
9. Other configuration may be developed, please enquire.
10. Higher temperatures may be possible however the performances will be reduced.
11. May not be attainable if the heat-sink performances are not sufficient i.e. a dissipation capability of less than 10W/K.
12. The typical values are obtained in nominal conditions, deviations to these conditions towards cooler environment will reduce the cooling requirement and increase them for higher temperature conditions. A heat dissipation capacity of 10 W/K is recommended
13. Overall dimensions, excluding 20 mm pins. Other configurations may be adapted, please inquire.
14. Off the shelf wavelength is 1270 cm⁻¹, up to 6 month lead time may required for other wavelength.

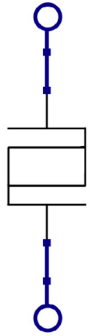

Frequency Comb Quantum Cascade Laser

Optical Frequency Combs are devices emitting light on a wide spectrum consisting of equidistant peaks in frequency space. The distance between these peaks being fixed, typically given by the pulse repetition rate of a train of ultrashort pulses, they can be used as rulers in the frequency domain for Frequency Comb Spectroscopy.

Electro-Optical Characteristics

SPECIFICATIONS	ACRONYM	MIN	TYP.	MAX	UNIT	NOTE
Central Wavelength	CWL	–	7.95	–	µm	1
Output Power	P	100	150	200	mW	2
Optical Frequency Span	OFS	50	60	70	cm-1	3
Number of Comb Teeth	N	100	120	140	–	4
Intermode Beat Frequency	IF	14.67	14.77	14.87	GHz	5
Operating current	I _{op}	600	800	1000	mA	6
Operation Temperature	T _{op}	-20	0	20	°C	7
Operation mode	–	–	CW	–	–	8
Delivery time	–	–	8	–	weeks	9
Dissipated Power	–	6	8	10	W	10

Key Features

- Compact and robust device
- Emission in the mid-IR molecular fingerprint region
- Power per comb tooth in the mW range
- FM modulated output with constant output power
- Direct generation of MWIR and LWIR radiation with high wall-plug efficiency
- Can be packaged in HHL or LLH housing

Key Applications

- Dual-comb spectroscopy
- Metrology
- Chemical sensing



CLASS 3B LASER PRODUCT

These specifications may be changed without further notice.

1. Frequency Comb Technology can be applied at any QCL available wavelength, please enquire for the lead time of your wavelength of choice. Presently lasers around 7.95 microns are available.
2. The output power varies with temperature and from one laser to another.
3. The optical frequency span will vary with the current and temperature.
4. Detailed in device's datasheet.
5. For a standard 3 mm long laser.
6. DC
7. Depends on each specific devices. It may be limited towards higher temperatures.
8. Frequency Combs are only stable in CW operation
9. At Reception of Order or specified in the quotation.
10. By the chip, if packaged, the total dissipation may be larger.

In the mid-infrared range, Quantum Cascade Lasers with specifically engineered optical dispersion have been shown to emit broad and powerful optical frequency combs (OFC). As for ultrashort-pulse lasers, the mode spacing of QCL combs is given by cavity length. However, in the case of QCLs, the periodic modulation in the time-domain is of the FM, not AM, type and the output power is constant.

The wide and flat gain spectrum of Broad Gain Lasers make them suitable for operation as Frequency Combs. As the operating range where comb operation can occur is very sensitive to the fine structure of the heterostructure, each QCL-Comb is tested and qualified.

The QCL comb is a stand alone device as it integrates the pump laser and the microcavity in its waveguide contrarily to other comb technologies. This makes it a very compact comb source. Being based on QCL technology, comb devices can be manufactured over all the MWIR and LWIR.

Dual-comb spectroscopy relies on two OFCs, a sample and a local oscillator (LO) comb, with slightly different comb spacings. The heterodyne beat spectrum of two such combs consists of equally spaced peaks mapping the lasers' optical spectra in the RF domain.

While a similar technique has also been demonstrated using standard Fabry-Perot QCLs, the much narrower intermode beat linewidth of QCLs operating in the comb regime allows to stack a much larger number of beat notes within the RF bandwidth of the optical detector, resulting in higher resolution and/or broader spectral bandwidth.

QCL-based dual-comb spectroscopy offers the possibility to acquire high-resolution spectra over a wide spectral range of several tens of cm^{-1} in a very short acquisition time of the order of μs , i.e. in quasi real time. This technique combines the advantages of DFB-QCLs, i.e. narrow linewidth and mode-hop-free tuning, with the large wavelength coverage of external cavity QCLs.)

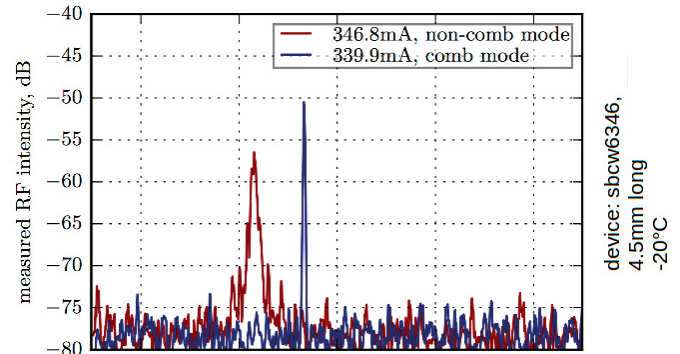

RF Spectrum of a Frequency Comb laser showing comb operation at an operating current of 339 mA

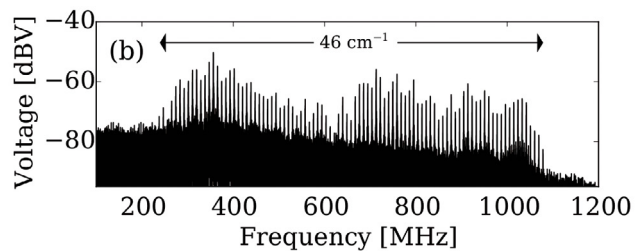
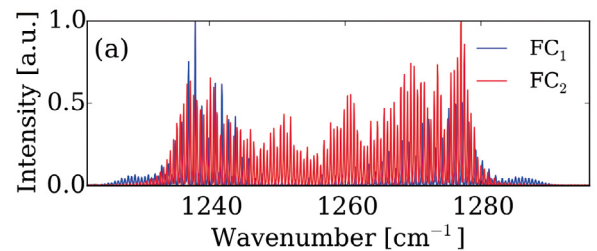

Top: Overlapping optical spectra of two typical Frequency Comb Lasers. Bottom: Muheterodyne beating spectrum of two combs, the spectrum spans 46 cm^{-1} and has a FWHM of 400 kHz

Source: Y. Bidaux et al., Plasmon-enhanced waveguide for dispersion compensation in mid-infrared quantum cascade laser frequency combs, Optics Letter page 1604, vol. 42, no 8, 2017

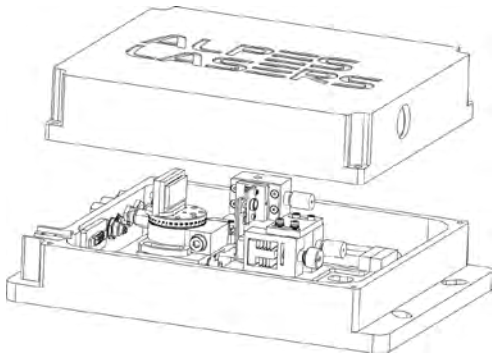

External Cavity Laser Kit

Alpes Lasers introduces the External Cavity Laser Kit. The kit contains a mount for a QCL chip and a grating on a rotation mount to allow for wavelength selection, a driver and a temperature controller. The optical output is a single-beam of light whose wavelength can be selected within a typical range of $\sim 200 \text{ cm}^{-1}$, a considerable advantage over the typical DFB range of 10 cm^{-1} .

The kit can be fitted with any FP or broad gain laser available from Alpes lasers, see on the table on the other side

Electro-optical Characteristics

SPECIFICATIONS	ACRONYM	MIN	TYP.	MAX	UNIT	NOTE
Spectral Linewidth	SL	-	1	2	cm^{-1}	1
Gapless tuning range	GTR	50	200	300	cm^{-1}	2
Grating period	GP	100	-	300	mm^{-1}	3
Sweep rate	SR	2700	-	13200	cm^{-1}/s	4
Spectral Accuracy / Repeatability	SA	0	0.5	2	cm^{-1}	5
Maximum peak power	MPP	40	100	400	mW	6
Average power	P	1	5	20	mW	7
Power stability	PS	-	-	5	%	
Pulse width	PW	20	300	CW	ns	8
Pulse repetition frequency	PRF	-	0.17	1	MHz	9
Duty cycle	DC	0.1	5	100	%	10
Beam quality	M^2	1.2	1.5	2.0	-	
Beam diameter	D	-	-	4	mm	
Beam divergence	Div	-	-	6	mrad	
Pointing stability	PS	-	-	6	mrad	
Operation temperature	Top	0	20	30	$^{\circ}\text{C}$	11
Cooling	-	Passive	Water	-	-	12
TEC current	TECI	-	-	5	A	
TEC voltage	TECV	-	-	6	V	
Dimensions	LxWxH	308	220	100	mm^3	13
Delivery time				12	weeks	

Key Features

- Large scanning range
- Pulsed operation (CW in some cases)
- Modular
- Highly Customizable
- Graphical interface
- REST API (Web)
- Direct access to all systems possible

Key Applications

- System development
- Teaching
- Gain material validation



CLASS 3B LASER PRODUCT

These specifications may be changed without further notice.

1. May be degraded in case of sub-optimal alignment.
2. These values may not be achieved by all gain media, the actual values for tuning range, peak power and average power are dependent on the selected gain medium.
3. The optimal grating for the selected chip will be included in the ECLK. If the user needs to operate the kit with chips of incompatible wavelength ranges it is possible to purchase additional gratings.
4. The values for a specific configuration will depend on wavelength and grating selected.
5. As the system does not contain a wavelength reference, the accuracy is fixed by the calibration that must be obtained from an external reference such as an FTIR or a Wavemeter. The numbers given take only into account the repeatability.
6. Tuning range, peak power and average power are dependent on the selected gain chip, the values given here are typical for most chips.
7. Tuning range, peak power and average power are dependent on the selected gain chip, the values given here are typical for most chips.
8. Not all chips are capable of CW operation. 300 ns is the typical test pulse length used when qualifying the kit.
9. 170 kHz is the typical prf used for qualification tests of the kit.
10. Not all chips are capable of CW operation. 5% is the typical duty cycle used for qualification tests of the kit.
11. Cold temperatures require water cooling. Temperatures below the dew point require a purging of the cavity.
12. Performances will depend on cooling options chosen. At low duty cycle typically passive cooling is sufficient. Beware that when operating below the dew point, purging is necessary.
13. This comprises only the Optical engine. The electronics comes additional.

Available FP and Broad gain lasers

LASER	TUNING FROM	TUNING TO	AVG. POWER AT OPTIMUM FREQUENCY
BG-4-3-5	< 1970 cm^{-1}	> 2270 cm^{-1}	> 2 mW
BG-5-6	< 1655 cm^{-1}	> 1860 cm^{-1}	> 10 mW
BG-6-7	< 1380 cm^{-1}	> 1540 cm^{-1}	> 1 mW
BG-7-8	< 1160 cm^{-1}	> 1420 cm^{-1}	> 2 mW
BG-11-14	< 800 cm^{-1}	> 885 cm^{-1}	> 1 mW
P-FP-6	< 1610 cm^{-1}	> 1650 cm^{-1}	> 8 mW
P-FP-9	< 1069 cm^{-1}	> 1141 cm^{-1}	> 5 mW
CW-FP-9	< 1070 cm^{-1}	> 1120 cm^{-1}	> 7 mW

[click to view these data online](#)

Alpes Laser's line of External Cavity Laser Kit (ECLK) is designed for single-mode operation with wide spectral tunability. The ECLK consists of a quantum cascade laser (QCL) gain chip, a grating-tuned extended optical cavity in Littrow configuration, driver electronics and control software. The kit is delivered assembled and may require alignment before use. Alignment documentation and training course are available. Additional gain chips with different wavelength coverage and/or output power can be purchased from Alpes Lasers and installed in the instrument by the user. The ECLK is compatible with the Alpes Lasers line of Broad Gain QCLs which tune over up to 25% of their center wavelength.

The system is entirely documented and open. It can easily be modified and customized for a specific purpose. The system comes with a controller providing a Web based graphical user interface allowing to access all the functionalities of the system. In addition for automation, or integration into a broader experiment control program, a REST API is made available to instruct the controller of the tasks to execute. It is also possible to operate without the controller and send commands directly to the various elements of the ECLK such as the rotation motor or the laser driver or the temperature controller.



ECLK outside



ECLK inside

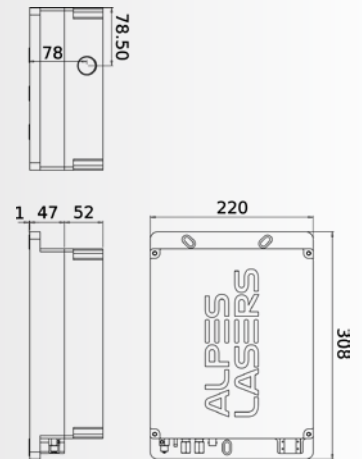

ECLK Main Dimensions

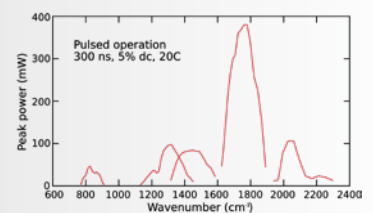

Tuning of available BG chips in ECLK

ALPES LASERS

How to tune a QCL*

Olivier Landry - Alpes Lasers

November 14, 2013

1 Short Pulses for narrow linewidth

The emitted wavelength of a DFB laser is given by the spacing of its Bragg grating, which is affected by temperature. In the case of a pulsed lasers, the sudden onset of electrical dissipation will increase the temperature during the pulse, which will create chirp. We give here some information on this behaviour.

At turn-on, this effect changes the emitted wavelength. The tuning rate is approximately 14 ppm/ns at the outset of the pulse and slows down rapidly after a few ns; the exact rates varying from one laser to another. It follows that, to obtain a narrow linewidth on a slow detector, the pulse length must be kept to a minimum.

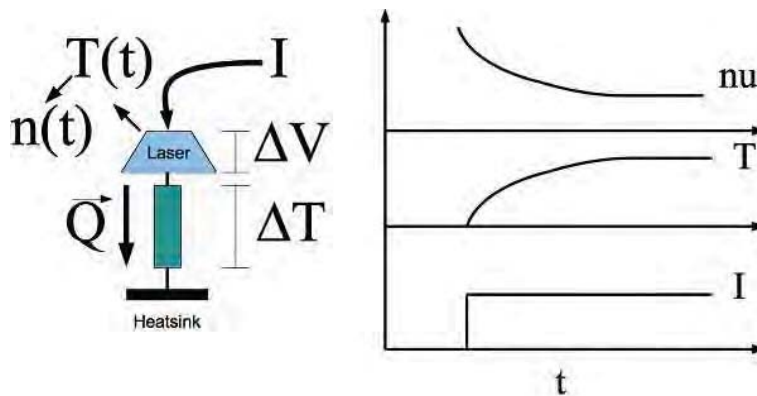

Figure 1: Behaviour at turn-on

The pulsed laser from Alpes Lasers are normally tested on their datasheet using a 50 ns pulse, which results in a noticeable linewidth shown on the datasheet spectra.

A shorter pulse can be used to reduce this linewidth. Using the QCL pulser provided by Alpes Lasers, pulses as short as 22 ns can be created. Dedicated electronics may be able to achieve even shorter pulses. However the non-linear electrical behaviour of QCL make the typical rise and fall-time of the pulse on the order of 8 ns, making very short pulses difficult to achieve.

As a final note, the effective linewidth can also seem to depend on the amplitude of the pulse. This is because there is typically an overshoot at the beginning of a pulse; this is especially pronounced at low

⁰CORID:6881_ArchiveAL-87886

amplitude and very short pulses. It may therefore seem as though a pulse is very short, while it is in fact below threshold, with only a short overshoot being above threshold. An increase in amplitude will then show the true length of the current pulse. You can see on figure 2 a typical shape for a short pulse: the actual spectral behaviour will vary depending on the location of the threshold with respect to the shoulder appearing after 7.9 ns.

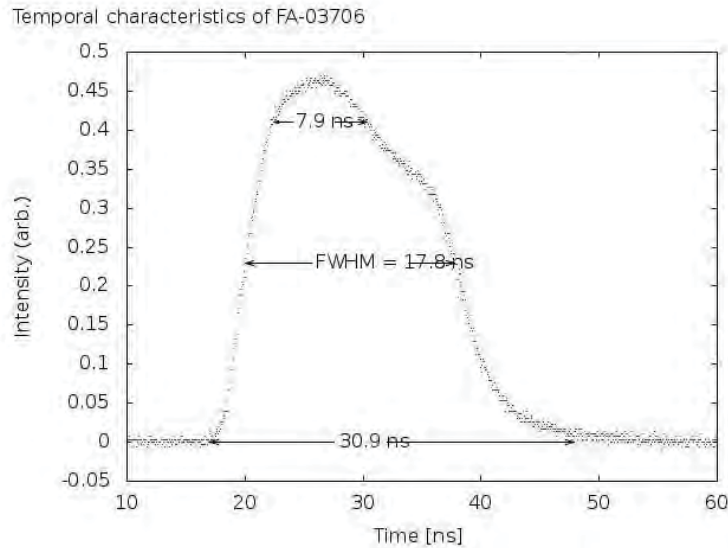

Figure 2: Typical light curve

2 Intra Pulse Modulation

The emitted wavelength of a DFB laser is given by the spacing of its Bragg grating, which is affected by temperature. In the case of a pulsed lasers, the sudden onset of electrical dissipation will increase the temperature during the pulse, which will create chirp. In the Intra-pulse modulation scheme, this chirp is resolved with a fast detector in order to scan through an absorption line.

The final resolution of this method depends on the scanning rate (which depends on the laser) and the detectors integration time. The scanning range can extend up to 2.5 cm⁻¹.

For more information, we refer you to this article published in the Journal of the Optical Society of America B:

http://www.alpeslasers.ch/fichier/papiers/interpulse_modulation_josab_20_8_1761.pdf

Typically, this method is used with pulses length ranging from 200 ns to 1 us. Not every laser chip can withstand such pulses! If you want to use the intra-pulse method, be certain to mention it in your request for quotation. Extra tests can be performed to ensure the suitability of a particular laser for this method.

3 Intermittent CW modulation scheme

One particular interest of quantum cascade lasers is their narrow intrinsic linewidths (down to <1kHz). To achieve a low effective linewidth, however, the driving scheme is important.

Three common driving schemes are inter-pulse modulation, intra-pulse modulation and CW modulation. They are described in more details elsewhere but each comes with their limitation:

short pulse schemes requires either fast current drivers (in the inter-pulse scheme) or fast detectors (in the intra-pulse scheme) to avoid the chirping inherent in pulsed lasers. CW modulation is more demanding on the laser itself and requires large heat dissipation.

We describe here a new scheme, dubbed Intermittent Continuous Wave (ICW) modulation, which allows one to perform spectroscopy with slow detectors and drivers while using lasers in TO-3 cans, which are less expensive than the LLH and HHL housing of true CW lasers.

This scheme was developed in collaboration with the Air Pollution / Environmental Technology group of EMPA.

3.1 Modulation schemes overview

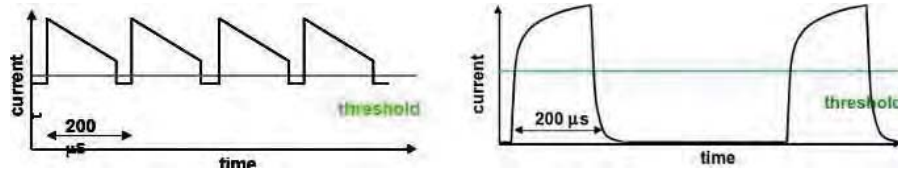

Figure 3: Driving scheme comparison

The image on the top-left shows a typical CW modulation scheme. The driving current is modulated in a saw-tooth pattern to create a frequency modulation over a 200 μs period, which is then followed by a short period below threshold and a repetition. This scheme allows for a slow frequency scanning: if the scanning range is 1 cm⁻¹, then a detector with a 1 μs time resolution will yield a spectral resolution of 0.005 cm⁻¹. The small current excursion ensures limited thermal effects.

Such CW modulation can be used with cooled lasers, for example in a HHL housing. However there are situations where the high footprint and power consumption required for running the laser in a constant-on mode are too high to be sustained.

The ICW scheme, shown on the top-right, diminishes the average dissipation in the laser by dropping the current to zero between pulses, and keeping a longer pause between pulses to allow the cooling down of the laser. Doing that, the overall dissipation is limited and the laser can be used in a TO-3 housing. The thermal excursion is larger which results in a faster transient tuning.

3.2 Requirements

ICW lasers must be lasers that would be capable of running in CW mode given enough cooling power. The ICW mode can be applied to any CW laser in a LLH or HHL housing. In addition, the ICW mode can be applied to a similar chip mounted in a TO-3 housing, but in this case a pure CW mode is not generally possible.

3.3 Ramps

The tuning rate can be controlled by applying a ramp to the current shape. In this case, the first 40 μs of the output is still discarded. Following that, the tuning rate can be increased or decreased by applying a current ramp to increase or decrease the thermal load on the active region of the laser. In this way, the total tuning range within a single pulse can reach up to 2 cm⁻¹.

The following pictures show again typical results. Each lasers will be individually tested.

3.4 Parameter Dependency

The overall tuning is almost entirely independent of submount temperature, but is dependent on duty cycle. Figure 5 shows relative tuning for different temperatures and inter-pulse separation for an identical pulse length.

The tuning endpoints and the tuning rate are both dependent upon the duty cycle. Figure 6 shows absolute tuning with respect to duty cycle. As the pulse-to-pulse separation becomes smaller, the behaviour approaches the monochromatic CW result.

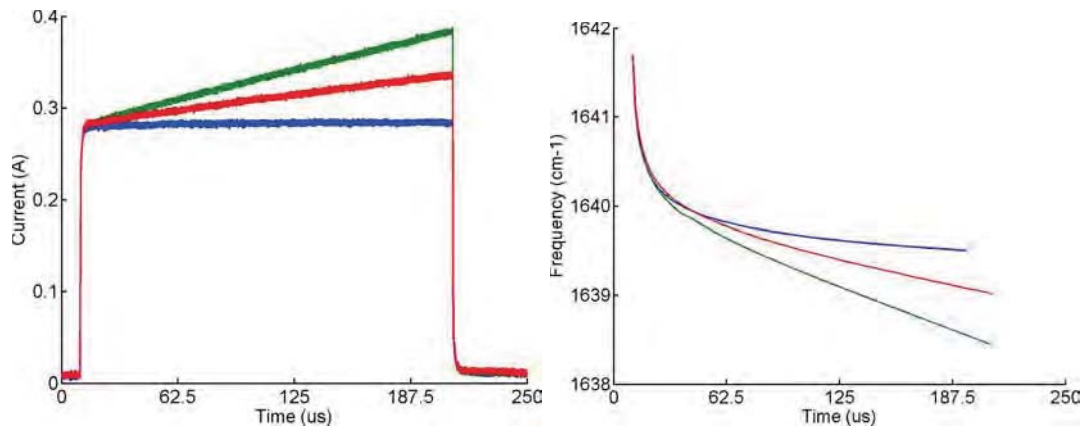

Figure 4: Effects of ramping

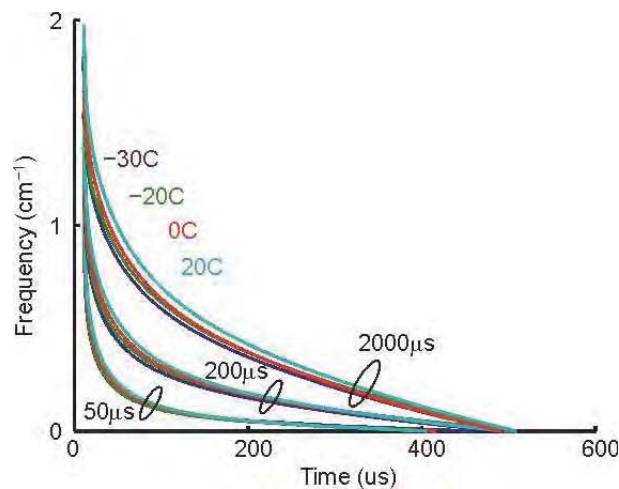

Figure 5: Temperature dependency

3.5 Hardware solutions

Square and sawtooth pulses can be created using programmable CW laser drivers. If you own such a driver you are welcome to use it and we will help you to find the best laser for such an application.

Alpes Lasers is also currently developing a driver fully dedicated to running lasers in the slow-chirp mode. We expect to be able to take orders for such drivers in 2014 - stay posted! Datasheets and Laser evaluation

Every CW laser mounted on NS mounts can be used in slow-chirp mode in a HHL or LLH housing. The datasheets shown on this website only reflects their performance in pure CW mode. If you enquire about these lasers, please precise the mode in which you intend to use them.

Since the long current pulse works by heating the laser, it is safe to assume wavelengths available in CW mode will also be available in ICW mode but with the base temperature being colder by about $10\text{Å}^\circ\text{C}$. The exact temperature shift will be affected by the current used in the laser and the duty cycle. The range available is typically greater than 1.0 cm^{-1} . A specific slow-chirp mode test under your conditions can be performed prior to shipping.

Lasers on NS mounts cannot be mounted in a TO-3 housing. Therefore for a TO-3 laser, please enquire directly by sending us an email at info@alpeslasers.ch

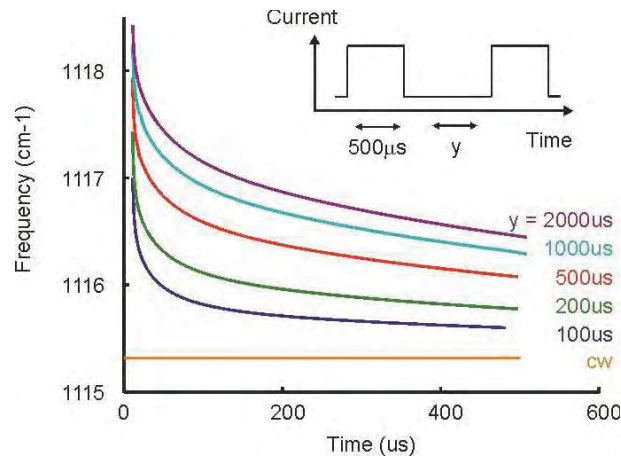

Figure 6: Duty Cycle dependency

4 Bias-T tuning

Since tuning of a QC laser is performed by changing the temperature of the active zone, a small sub-threshold DC bias current can be used to control the emission wavelength of pulsed laser via its heating effect. The LDD driver is equipped to accept a dual input, and this mode of operation is described in more details in Appendix B.3 of the Manual. If you have a gas cell available, you can also follow the sample start-up procedure.

Some of the first reported gas detection experiments were performed using the bias-T tuning method; such as for example the N₂O and CH₄ detection experiment reported in the 1998 Optics Letter available here:

http://www.alpeslasers.ch/fichier/papiers/tildas_ol_23_3_1998.pdf

4.1 Sample Start-up Procedure

To start:

1. Start the laser. A good temp to dial in at first is $\approx 15^{\circ}\text{C}$ so that any moisture inside the package does not condense on the laser chip. Use current settings as indicated in the Alpes test data. You should see energy if you monitor output with a detector.
2. Change the temp to one that should allow the highest frequency (shortest wavelength) of interest.
3. Reset the current to settings appropriate for that temp and wavelength and then reduce it a little bit further, but not below threshold (so you still see energy on the detector)
4. Put a gas cell between laser and detector and verify that you can still see the laser energy on the detector. Write down the value of the amplitude of the detector signal.
5. Turn on the bias T current to a low value (maybe 0.001A) and record the detector signal; repeat at 0.001A increments of bias-T current recording values for each increment until you have reached 0.060 A or some other value that has been discussed/agreed with Alpes.

What the above procedure has done is to generate a spectral scan of the laser over a wavelength region defined by the scan rate of the laser versus current (cm-1/A, a basic property of the laser). A 60 mA range might be equivalent to 1.2 cm-1 of wavelength change in the laser. If your starting point (temp, current) was right, you should see the line of interest in the data when plotted. If not, try again with new temp/pulse current. Continue to optimize the temp and drive parameters:

- Adjust the pulse length lower and higher and repeat the scan; thus learn about the effect of these parameters on power and laser linewidth; explore these to optimize the measurement

- If possible, repeat the measurement with a gas cell with the target gas at low pressure (1 Torr). This will narrow the line greatly and allow you to consider the apparent spectral resolution of the laser itself under the drive conditions and to learn whether the driver has any ringing or double pulsing (which will make the line width seem higher).

In the end you will have calibrated and optimized the laser spectrally as a function of temp and current and the values you have discovered will be much more precise than the values in the data supplied by Alpes (because there can be disagreements in calibration of current or temperature and because Alpes data is at a few discrete settings and your data is with your equipment against your target gas). You can use these optimized values to acquire your real gas data.

5 Direct CW modulation

A CW laser will settle to a fixed wavelength after a transient time of 10 ms; therefore you can modulate the laser with a signal slower than 100 Hz and expect the output wavelength to faithfully follow the input current with the relation measured in its datasheet.

CW lasers can also be modulated more quickly. The emitted power will follow the current amplitude faithfully at high speeds; for reference you can see this paper describing a free-space link functioning at 330 MHz:

http://www.alpeslasers.ch/fichier/papiers/blaser_el_37_778_2001.pdf

However the wavelength modulation being a thermal effect, it will be suppressed at speeds exceeding 1 MHz, and will decrease monotonously between 100 Hz and 1 MHz. Graph 7 shows data for an amplitude a specific laser; the exact values will vary from one laser to the next.

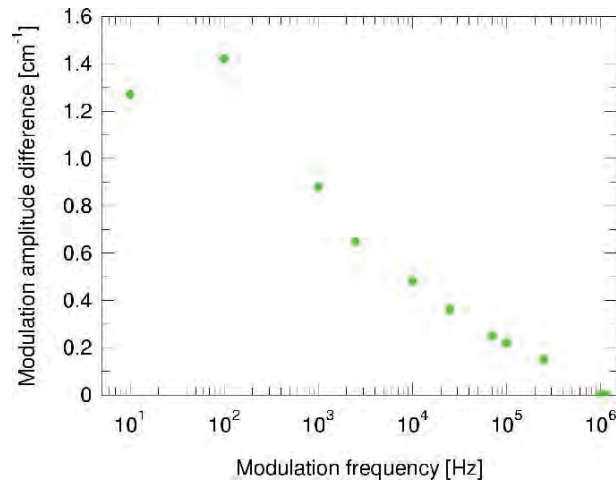

Figure 7: Modulation speed effect

Starter Kit

- Entirely manually controllable
- Modular system, devices can be selected or replaced by user
- High temperature operation range -30°C..70°C
- Exchangeable laser sub mount
- Anti Reflection Coated (3.5 to 12 μm) ZnSe window on laser housing
- Monitoring of laser voltage, current, pulse frequency and duty cycle.
- Pulse rate from 0 to 2 MHz
- PT100 temperature sensor, 4 wire measurement
- Internal/External temperature setting
- Monitor-output for real temperature
- Laser overheat-protection by Interlock-system
- Numerous options available (length of the low-impedance line, TC on rack,...)
- Numerous Starter Kits already installed in majors universities and R&D labs all over the world since several years



Quantum Cascade Lasers

- Wide range of wavelengths from 4 to 17 μm
- Operation at room-temperature
- Mono-mode and tunable emission
- Narrow linewidth
- High optical power up to 300 mW
- High reliability and lifetime
- Available on die or mounted on different sub mounts
- Fully independent and individually tested device
- Small size



Available wavelength (other wavelengths available on our web site)

Wavelength [μm]	Wavenumber [cm-1]	Application(s)
4.86	2058	CO ₂ , CO
4.87	2055	CO ₂ , CO
5.25	1904	NO, H ₂ O
5.45	1835	NO
6.13	1631	NO ₂
6.28	1592	NO ₂ , NH ₃
7.43	1345	SO ₂ , H ₂ S, CH ₄
7.62	1313	N ₂ O, CH ₄ , H ₂ S
7.85	1274	H ₂ O, CH ₄ , N ₂ O, C ₂ H ₂ , H ₂ S
7.87	1270	H ₂ O, CH ₄ , N ₂ O, C ₂ H ₂ , H ₂ S
9.71	1030	O ₃
10.38	963	NH ₃
11.49	870	CH ₃ Cl



LN2-P-FP-QCL-136 TeraHertz Quantum Cascade Laser

Far Infrared
Pulsed
Multimode
Cryogenic Temperature
136 cm⁻¹



LN2 dewar

Optical and Electrical Characteristics

Parameter	Min	Typical	Max	Units
Wavenumber range	140	136	133	cm ⁻¹
Wavelength range	71	73	75	μm
Frequency range	4.22	4.11	4	THz
Operation temperature	-	77	-	K
Threshold current	-	1.45	-	A
Operation current	1.45	-	2	A
Peak output power	-	2	-	mW

Example: LI Curves and Spectra of LN2-P-FP-QCL-136

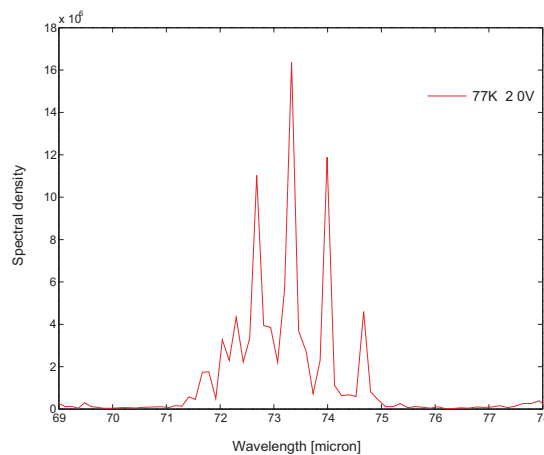
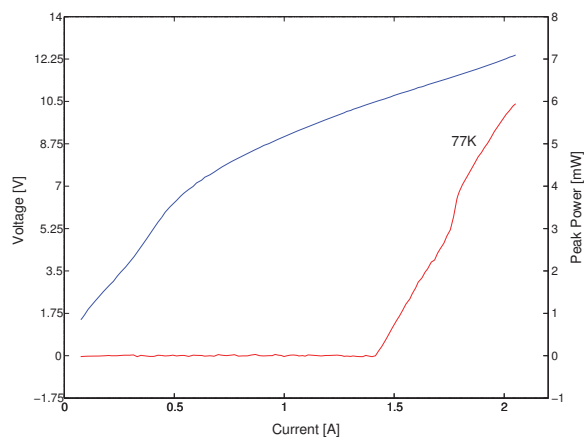

Closed Cycle TeraHertz Source

A portable, plug-in-the-wall, cryogenic-liquid free source of THz light by Alpes Lasers.



- Dimensions : 200 x 250 x 350 mm
- Weight: 17 Kg
- Max. total power consumption: 300W
- Cool-down time to operation ready (65K): 15 minutes
- Minimum operation temperature – cold side: 65K
- Acoustic noise: < 30dB

Dual laser inside. Different spectra available.

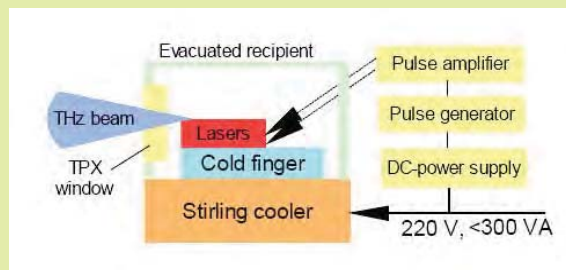
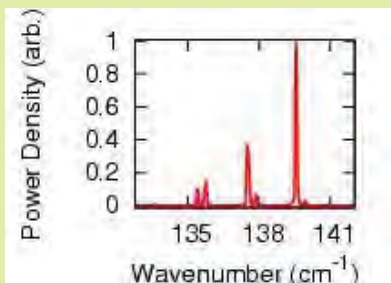

Availability

Emission range				Peak power	CW	Max CW power
[Thz]		[cm ⁻¹]				
1.2	1.6	40	53	>300 μW	Yes	100 μW
1.2	1.6	40	53	>100 μW	No	
1.2	1.6	40	53	>10 μW	No	
2.2	2.6	73	86	>5 mW	No	
2.8	3.6	92	122	>1 mW	No	

Imaging capabilities:
e.g. 100 μm wire in black PE pouch.



Alpes Lasers SA
Passage Max Meuron 1-3
Case Postale 1766
CH-2001 Neuchâtel

Tel: +41 (0)32 729 95 10
Fax: +41 (0)32 721 36 19

<http://www.alpeslasers.ch>
info@alpeslasers.ch



PRODUCTS

Distributed Feedback Laser (Single mode)

- Operation in pulsed mode
- Two different mountings available:
 - TH mounting (bolt down) Size: 20 x 6 x 3.2 mm³
 - SB mounting (clamp-holder) Size: 19 x 7 x 2 mm³
- Room temperature operation
- Output power:
 - Average: 2 - 10 mW
 - Peak: 100 - 500 mW
- Beam divergence (full angle):
 - 60° perpendicular
 - 40° parallel

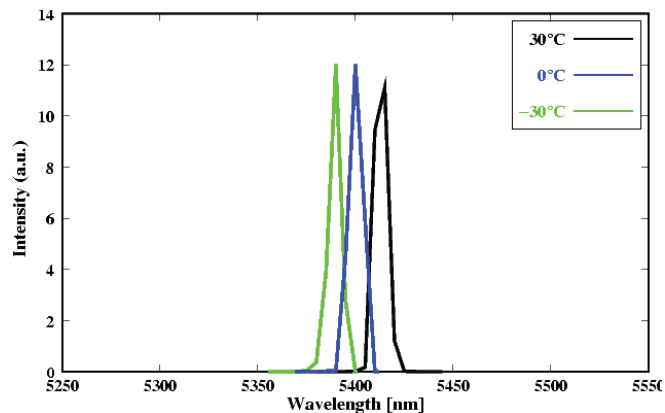
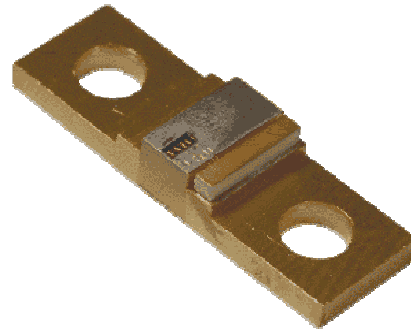

Available wavelengths:

5.3 - 6.0 μm and 10.0 - 10.5 μm

Lead time 2-8 weeks

Fabry-Perot Laser (Multimode)

- Operation in pulsed mode
- Two different mountings available:
 - TH mounting (bolt down)
Size: 20 x 6 x 3.2 mm³
 - SB mounting (clamp-holder)
Size: 19 x 7 x 2 mm³
- Room temperature operation
- Output power:
 - Average: 2 - 10 mW
 - Peak: 100 - 500 mW
- Beam divergence (full angle):
 - 60° perpendicular
 - 40° parallel

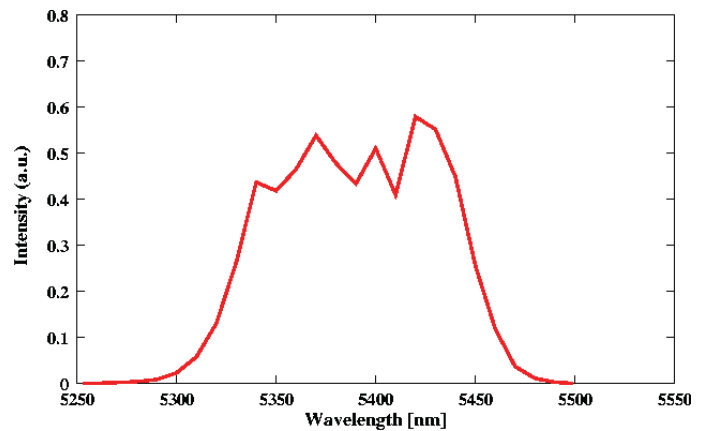
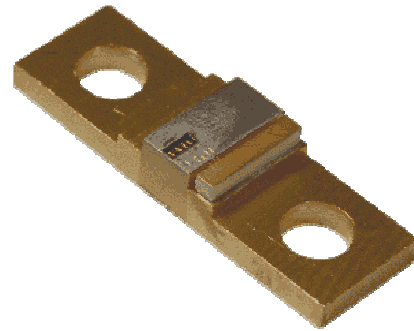

Lead time 2-8 weeks

Available wavelengths:

5.0 - 6.2 μm and 8.5 - 10.5 μm

Starter kit

Equipment for operating Distributed-Feedback-Laser and Fabry-Perot-Laser.

Overview:

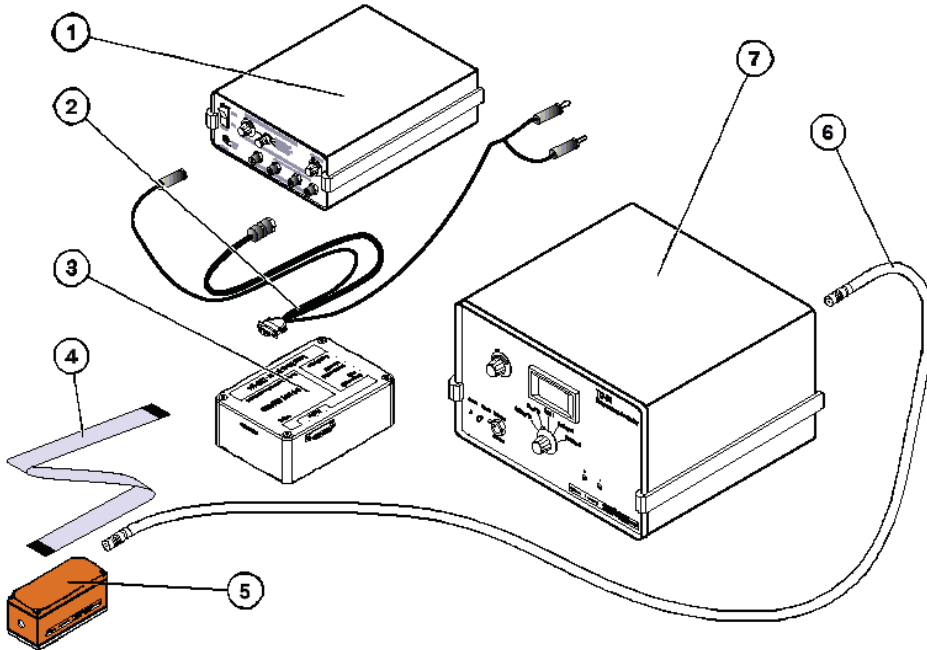

This kit contains: (1) Pulse generator, (2) connector cable to (3) pulse switcher, (4) low impedance line conducting pulses to (5) laboratory laser housing. Power supply of internal cooling elements via (6) connector cable by (7) temperature controller.

Lead Time 2 weeks

How to get started:

Just place the laser into the thermally stabilized Laboratory Laser Housing and connect your own external DC-power supply (30V, 1A..50V, 2A; depending on the laser).

Laboratory Laser Housing - LLH

- Peltier cooled laser-stage inside, minimal temperature $<-30^{\circ}\text{C}$
- Laser power supply by low impedance line from [LDD](#)
- Anti Reflection Coated (3.5 to 12 μm) ZnSe window.
- Exchangeable laser sub mount.
- Direct voltage measurement on the laser connection, AC coupled.
- PT-100 or NTC temperature measurement.
- Needs air or water-cooling.
- Temperature stabilization and power supply by [TC51](#)
 - Size: 10cm x 5cm x 5cm



Low impedance line

- Length: 0.5m

Lead time 2 weeks

Laser Diode Driver - LDD100

- Peak Current up to 15 Amps
- Voltage up to 50 Volts
- Low impedance connection to [LLH](#)
- 12 V DC power supply, provided by [pulse generator](#)
- TTL 50 Ohm input
- Monitor: laser voltage, current, pulse frequency & duty cycle.
- Rise/fall time 10 ns
- Pulse duration min 10ns (with attenuation), flat from 20ns to DC
- Pulse repetition rate 0 to 1 MHz (possible to 2 MHz, but not linear)
- Size: 15cm x 6cm x 9 cm



Lead time 2 weeks



LDD supply cable

- Length: 2.0m

Lead time 2 weeks

Pulse Generator - TPG128

- Two TTL 50 Ohm output
- Synchronization output
- Rise/fall time < 10 ns
- Pulse duration 20 to 200 ns
- Pulse repetition rate 10 kHz to 5 MHz
- Gate input
- Power supply 220V, 50-60 Hz
- This unit drives the LDD (duty cycle up to 20%)
- Size: 22cm x 7cm x 13.5cm



Lead time 2 weeks

Temperature Controller - TC51

- Temperature range: -35°C .. +65°C
- PT100 temperature sensor
- Internal/External temperature setting
- Monitor-output for real temperature
- Laser overheat-protection by Interlock-system
- This unit stabilizes temperature of laser in LLH



- Size: 11.5cm x 22cm x 27.5cm



Connector cable TC51 - LLH

- Length: 1.3m
- provides current for Peltier elements and connects Pt-100 sensor to [TC-51](#)

Lead time 2 weeks



S-2 QCL Pulser

The S-2 QCL Pulser is designed to provide fast, high impedance current pulses to non-linear current driven devices such as quantum cascade lasers. The generated pulses have a rise time between 5 and 15 ns.



The S-2 driver is controlled directly through a computer terminal when the S-2 is connected by a serial or USB cable. Drivers for [Mac OS X](#), [Linux](#) or [Windows](#) computers are available.

If the software requires to upgrade the firmware, you can use the firmware upgrader for [Mac OS X](#), [Windows](#) or for [Linux](#) to upgrade to the latest version.

If your computer does not recognize the USB-RS 232 converter, you can find a driver [here](#); most computers should recognize the converter without a specific installation.

S-2 Pulser Specifications

Max. Repetition Rate	1 MHz
Pulse Width	20ns to CW in 20 ns increment
Max Output Voltage	25V
Voltage Setting Resolution	5 mV
Current Measurement Resolution	2 mA
Max. Current Output	8 A peak, 2.5 A average
Output Voltage Modulation	1 kHz
Bandwidth	1 kHz
Input Voltage	8-20V
Power Supply (included)	18V/40W
External Modulation/Trigger	included
Overcurrent Protection	included



Low impedance High Current Pulser

The S-3 High Power Pulse Generator is designed to drive devices requiring short or long pulses of high current with a non-linear response, including optical devices such as high power quantum cascade lasers, infrared laser diodes, LEDs or electronic devices such as Gunn diodes or high speeds transistors and rectifiers.

Specifications

QUANTITY	MIN	TYP	MAX	UNIT	NOTE
Max Pulse Repetition Frequency	–	–	1	MHz	
Low impedance head size	88	42	22	mm ³	
Voltage setting/measurement resolution	–	5	–	mV	
DC bias Tee max current	–	30	–	mA	
DC bias Tee current resolution	–	10	–	µA	
Analog input resolution	–	1	–	mV	
DC bias Tee current slew rate	–	–	3	A/s	
Amplitude slew rate	–	20	–	V/s	
Analog input range	0	–	3.3	V	
Trigger Level			TTL		
Gate Level			TTL		
Maximum peak current	–	–	8	A	1
Maximum voltage	–	–	25	V	2
Maximum average current	–	–	3	A	3
Pulse width	20	–	DC	ns	4
Pulse width minimum increment	–	20	–	ns	5
Pulse repetition period resolution	–	–	20	ns	6
Rise time	2.5	5	–	ns	7
Fall time	2.5	5	–	ns	8
Current measurement resolution	–	2	–	mA	9
Pulser box size	200	220	130	mm ³	10

Key Features

- Small footprint low impedance head
- Convenient access to all signals
- Up to 8A peak/3A average current
- Voltage compliance: 25 V
- Computer control of output voltage
- Computer or TTL control of pulse sequence
- Stand alone operation possible once programmed

Key Applications

- Lab driver for pulsed QCLs
- Multi purpose low impedance driver
- Driver for highly non-linear loads
- Laser Range Finding
- High power short rise time applications

These specifications may be changed without further notice.

1. Please inquire about higher current versions.
2. Limited by capacitors
3. Limited by heat extraction
4. Strictly speaking, from 20 ns to 1.3 ms in 20 ns increments, then up to 85 s with larger increments, and CW
5. Up to 1.3 ms for internal modulation and for externally modulated operation, any pulse length and frequency will be reproduced identically to the source.
6. Periods from 1000 to 1310700 ns with 20 ns resolution; periods up to 85 s with lower resolutions (multiples of 20 ns).
7. This is mostly defined by the load; the values given are for AL's HHL and LLH packages with proper cabling; with inductive loads the rise time can be much worse than 5 ns
8. See the note for the rise time
9. Beware that for pulse length below 300 ns the value is overestimated and indicative only. The quantity is measured every pulse and averaged over multiple measurements providing a refresh rate of 10Hz.
10. Including connectors

The S-3 is a good replacement for the obsolete Keysight/Agilent 8114A or the AV-107 from Avtech and provides additional features. The S-3 offers many programmable options and can be programmed from a computer through its USB port but once this done, if you plan to use the device continuously, you can just have it start at turn on and do not need any computer command to turn it on for full stand-alone operation.

The device can operate as a slave, reproducing a control pulse or its internal clock can be used to produce pulses or trains of pulses in most relevant configuration.

The device contains an external enable/disable TTL control that allows full operation in Quasi-CW mode of a QCL, Laser Diode or any load.

The device contains an internal DC bias Tee allowing to add a DC dither in between the pulses to create a DC additional dissipation. This is controlled independently from the pulse current. This is particularly useful for pulsed QCLs to adjust wavelength without changing pulse current or heat sink temperature.





High power and single frequency quantum cascade lasers for chemical sensing

Stéphane Blaser

final version: <http://www.alpeslasers.ch/Conference-papers/QCLworkshop03.pdf>



Collaborators

Alpes Lasers

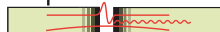

Yargo Bonetti
Lubos Hvozda
Antoine Muller
Guillaume Vandeputte
Hege Andersen



This work was done in collaboration
with the University of Neuchâtel

Marcella Giovannini
Nicolas Hoyler
Mattias Beck
Jérôme Faist

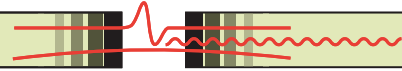

Outline

- Company profile
 - Introduction - state of the art
 - High power Fabry-Pérot devices
 - Applications
 - Distributed-feedback lasers
 - High power pulsed DFB devices
 - >77K operating continuous-wave DFB devices
 - Reliability
 - Production
-

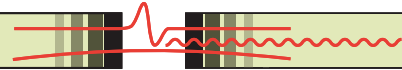

Company profile

- Founded August 1998 as a spin-off company from the University of Neuchâtel
 - incorporated as a SA under swiss law with a capital of 100 kCHF)
- Founders
 - Jérôme Faist
 - Antoine Muller
 - Mattias Beck
- Employees (September 2003)
 - 8 persons (6 full-time)



Installed at Maximilien-de-Meuron 1-3,
2000 Neuchâtel since April 2002

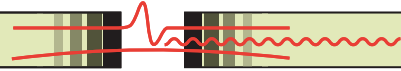

Company profile

- > 30 man-years experience
- 7 patents on QCL technologies

- > 150 devices sold
- > 50 customers

- turnover 2003: > 1.3 MCHF
- average growth rate: 100% / year

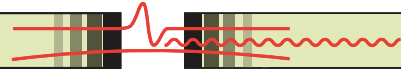

Quantum cascade lasers

Interband vs intersubband

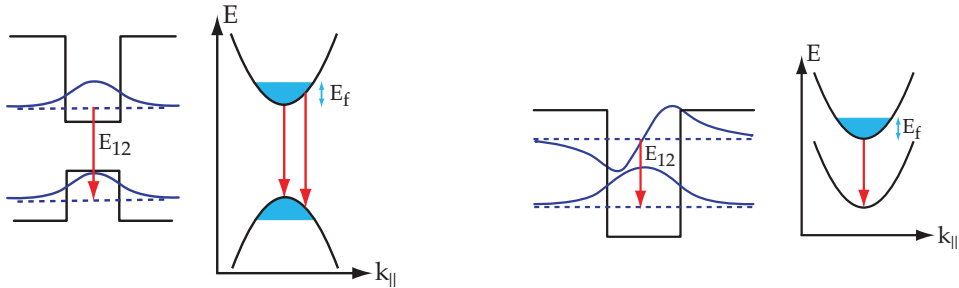

- **Interband transition**

- bipolar
- photon energy limited by bandgap E_g of material
- Telecom, CD, DVD,...

- **Intersubband transition**

- unipolar, narrow gain
- photon energy depends on layer thickness and can be tailored

Quantum cascade lasers

- **Cascade**

- each e- emits N photons

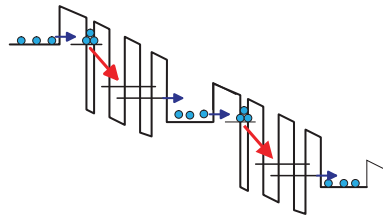

- **Active region / injector**

- active region \rightarrow population inversion which must be engineered
- injector \rightarrow avoid fields domains and cools down the electrons

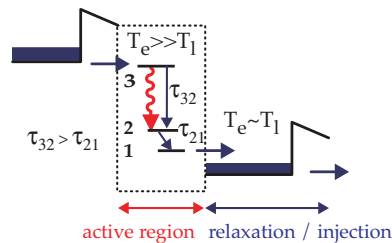

- **MBE**

- growth of thin layers
- sharp interfaces

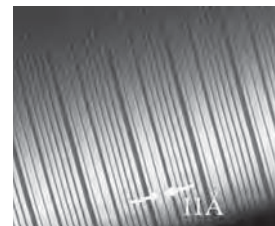

State of the art: QCL performances

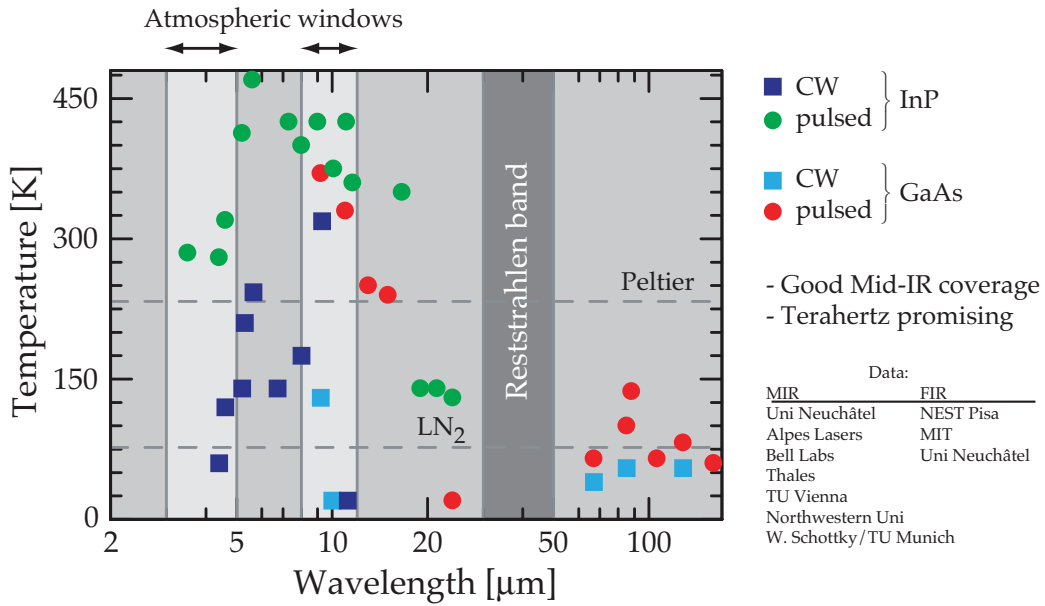

Designs

Double-phonon resonance:

(patent n° wo 02/23686A1)

- 4QW active region with 3 coupled lower state
- lower states separated by one phonon energy each
- keeps good injection efficiency of the 3QW design

Hofstetter *et al.* APL **78**, 396 (2001).

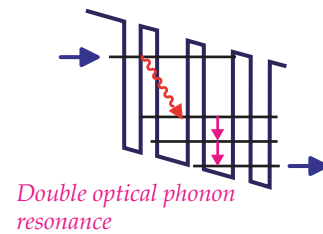

Bound-to-continuum:

(patent n° wo 02/019485A1)

- transition from a bound state to a miniband
- combines injection and extraction efficiency
- broad gain curve -> good long-wavelength and high temperature operation

J. Faist *et al.* APL **78**, 147 (2001).

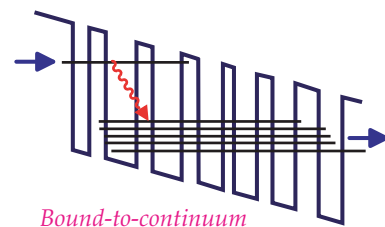

Two-phonon structure at 8 μm

Based on two-phonon resonances design

InGaAs/InAlAs-based heterostructure with $\Delta E_c = 0.52\text{eV}$

Grown by MBE on InP substrate

35 periods

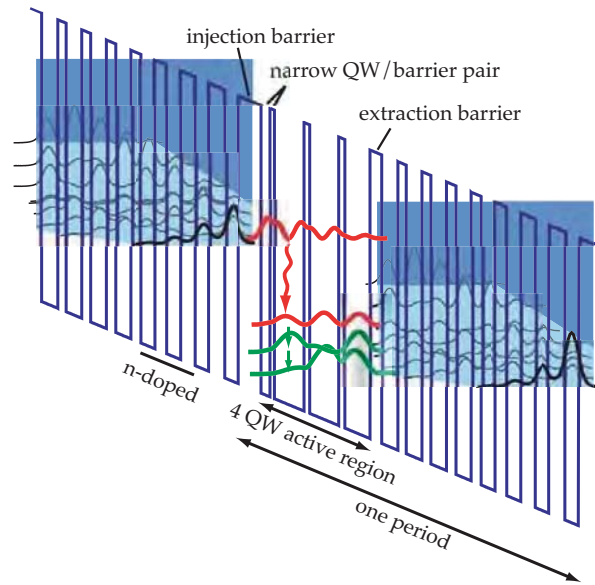

41, 16, 8, 53, 10, 52, 11, 45, 21, 29, 15, 28, 16, 28, 17, 27, 18, 25, 21, 25, 26, 24, 29, 24

High average power FP QCL

RT-HP-FP-150-1266

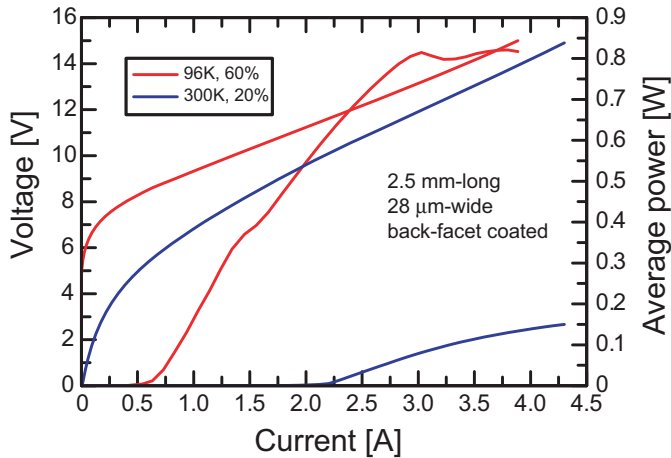

Characteristics

$\lambda = 7.9 \mu\text{m}$

@300K: Average power:
 $P = 150 \text{ mW}$
 threshold current:
 $I_{th} = 2.1 \text{ A}$ ($j_{th} = 3.0 \text{ kA/cm}^2$)

@96K : $P = 0.82 \text{ W}$ (60% dc)
 $I_{th} = 0.51 \text{ A}$ ($j_{th} = 0.75 \text{ kA/cm}^2$)
 CW: $P = 300 \text{ mW}$
 $(j_{th} = 0.78 \text{ kA/cm}^2)$

Array of lasers

DUAL-RT-HP-FP-40-1266

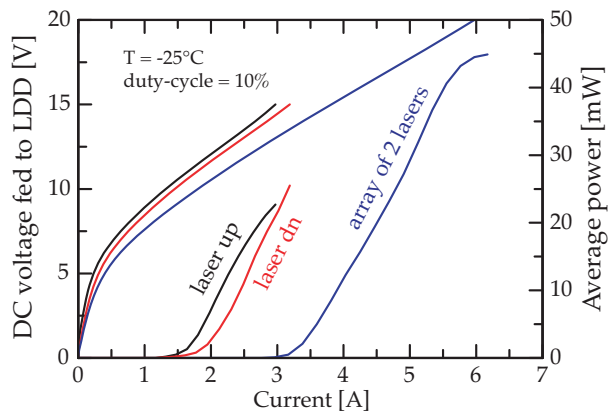

Characteristics

both lasers: 1.5 mm-long, 28 μm-wide
 $\lambda \approx 7.9 \mu\text{m}$
 T = -25°C, duty-cyle = 10%

laser	Average power	I_{th} [A]	J_{th} [kA/cm ²]
up	25.4 mW	1.8	4.29
dn	22.6 mW	1.6	3.81
array	44.9 mW	3.4	4.05

- Total power $\approx 90\%$ (P_1+P_2)
- Total threshold current $\approx I_1+I_2$

Applications

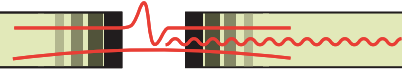

Applications: telecom

• Telecommunications

- Free-space optical data transmission for the last mile (high speed with no need for licence and better operation in fog, compared to $\lambda = 1.55 \mu\text{m}$)

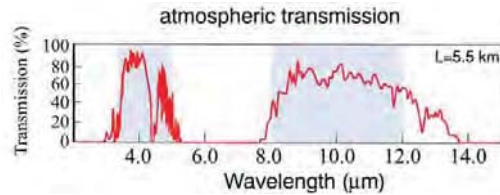
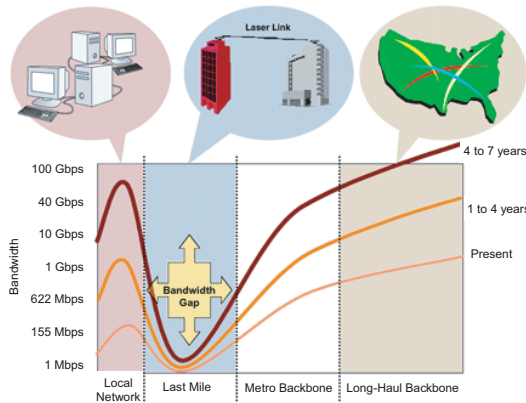

R. Martini et al., IEE Elect. Lett. 37 (11), p. 1290, 2001.
S. Blaser et al., IEE Elect. Lett. 37 (12), p. 778, 2001.

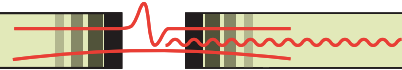

Main application: chemical sensing by optical spectroscopy

Detection techniques already demonstrated using QCL:

- photo-acoustic
 - B. Paldus et al., Opt. Lett. 24 (3), p.178, 1999.
 - D. Hofstetter et al., Opt. Lett. 26 (12), p. 887, 2001.
 - M. Nägele et al., Analytical Sciences 17 (4), p. 497, 2001.
- TILDAS
 - M. Zahniser et al. (Aerodyne Research), TDLS'03.
- cavity ringdown
 - B. Paldus et al., Opt. Lett. 25 (9), p. 666, 2000.
- absorption spectroscopy
 - A. Kosterev et al., Appl. Phys. B 75 (2-3), p. 351, 2002.
- heterodyne detection scheme
 - D. Weidmann et al., Opt. Lett. 29 (9), p. 704, 2003.
- cavity enhanced spectroscopy
 - D. Bear et al. (Los Gatos Research), TDLS'03.

Some needs:

high-power laser

single mode

continuous-wave

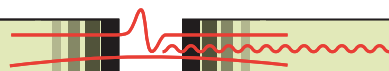

Application fields

- Chemical sensing or trace gas measurements
 - process development
 - environmental science
 - forensic science
 - process gas control
 - liquid detection spectroscopy
- Medical diagnostics
 - breath analyzer
 - glucose dosage
- Remote sensing
 - leak detection
 - exhaust plume measurement
 - combat gas detection

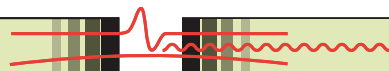

Simultaneous 3-gas measurements with dual-laser QCL instrument

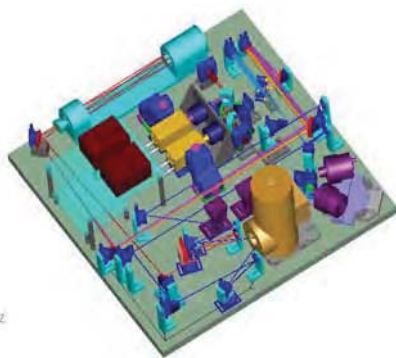

Two QC-lasers from Alpes:
2 to 6 gases (CH_4 , N_2O , NH_3)
56 m cell path length
Detector options

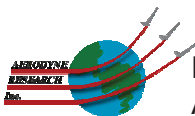
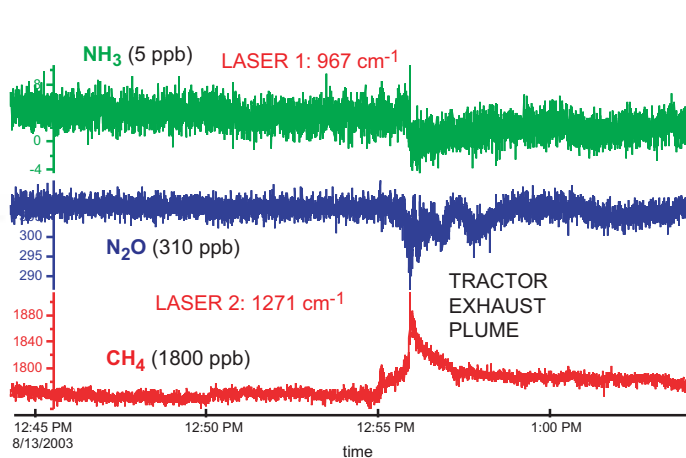

M. Zahniser et al.,
Aerodyne Research Inc., Billerica (USA)

Spectrum covered by Alpes Lasers dfb QCLs

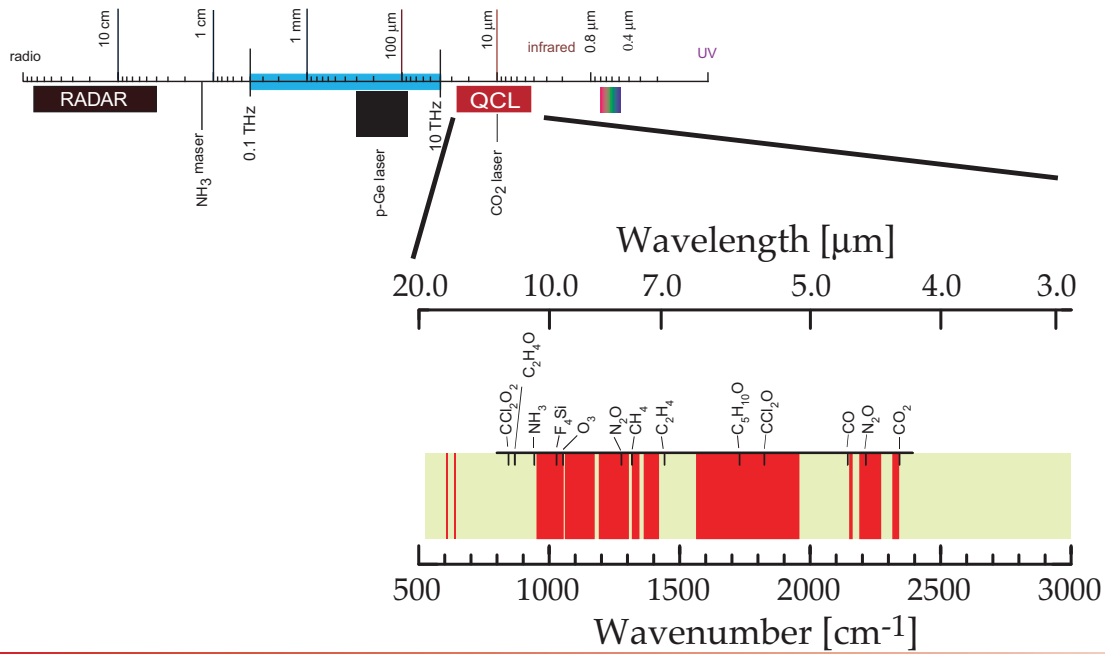

Single-mode operation: distributed-feedback QCLs

How does a DFB work?

Fabry-Pérot laser:

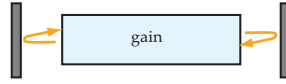

Amplified light bounces in the cavity

DFB:

periodic grating => waves coupling
=> high wavelength selectivity



complex-coupled DFB:

- lasing mode closest to the stopband
- stopband \approx coupling strength

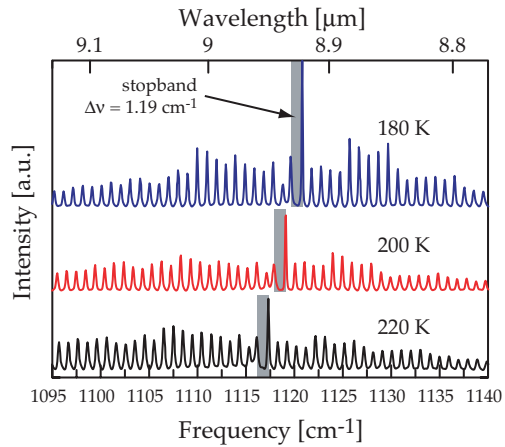

Distributed-feedback technologies

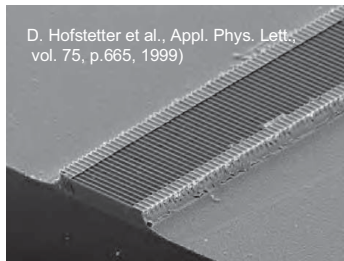

Grating on the surface (open-top)

- one MBE run (no MOCVD)
- high peak power (large stripes) but low average power
- optical losses due to metalization

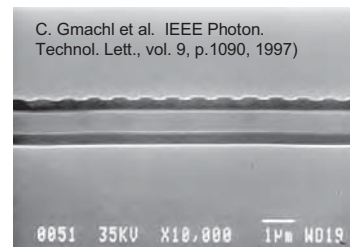

Grating close to active region

- lower thermal resistance (high duty / high temperature)
- high average power
- higher overlap, smaller losses
- jct dn mounting possible
- needs MOCVD regrowth

High average power DFB QCL

RT-HP-DFB-20-1200

Distributed feedback QC laser at 8.35μm with InP top cladding

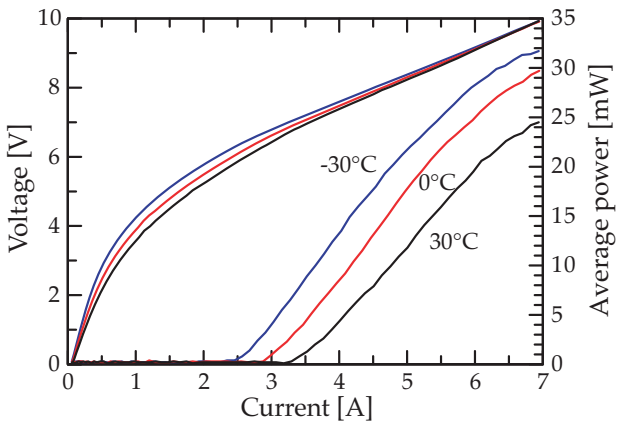

Characteristics

3mm-long, 28μm-wide laser
 $\lambda \approx 8.35 \mu\text{m}$

@-30°C: Average power (2% dc):
 P = 32 mW (1.6 W peak power)
 threshold current:
 $I_{th} = 2.44 \text{ A}$ ($j_{th} = 2.9 \text{ kA/cm}^2$)

@30°C : P = 25 mW (1.25W peak power)
 $I_{th} = 3.2 \text{ A}$ ($j_{th} = 3.8 \text{ kA/cm}^2$)

High average power DFB QCL

RT-HP-DFB-20-1200

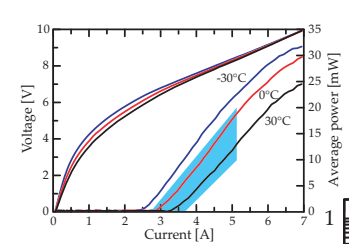

Characteristics

Entire tuning range:
 $\Delta\nu = 5.7 \text{ cm}^{-1}$ at 1197 cm^{-1} (0.47%)
 (1195.2 cm^{-1} (8.367 μm) at 30°C to 1200.9 cm^{-1} (8.327 μm) at -30°C)

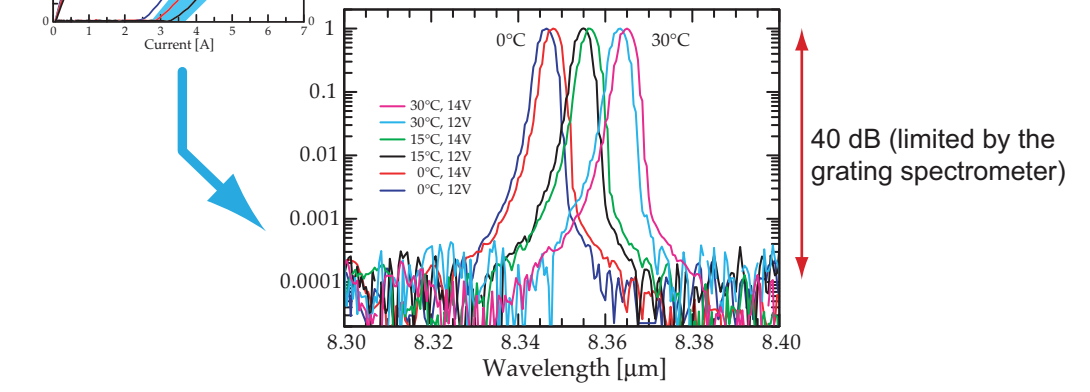

Long-wavelength ($\lambda \approx 16.4 \mu\text{m}$) B2C DFB QCL

RT-P-DFB-1-608

Laser based on a bound to continuum design, $\lambda \approx 16.4 \mu\text{m}$
 Rochat et al., APL **79**, 4271 (2001)

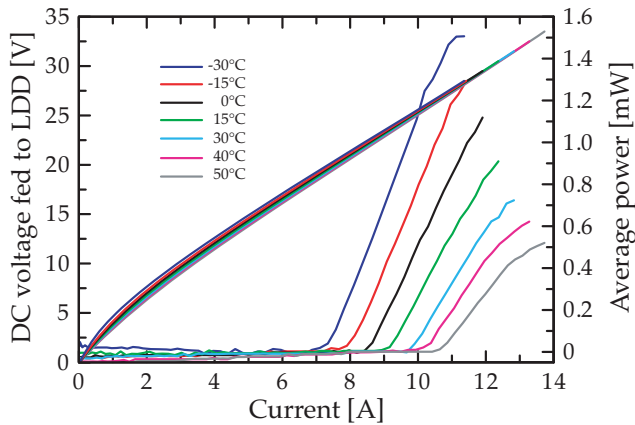

Characteristics

3 mm-long, 44 μm -wide laser
 $\lambda \approx 16.4 \mu\text{m}$

@-30°C: Average power (1.5% dc):
 P = 1.5 mW (100 mW peak power)
 Threshold current:
 $I_{th} = 7.1 \text{ A}$ ($j_{th} = 5.4 \text{ kA/cm}^2$)

@50°C : P = 0.5 mW (33 mW peak power)
 $I_{th} = 10.4 \text{ A}$ ($j_{th} = 7.9 \text{ kA/cm}^2$)

Long-wavelength ($\lambda \approx 16.4 \mu\text{m}$) B2C DFB QCL

RT-P-DFB-1-608

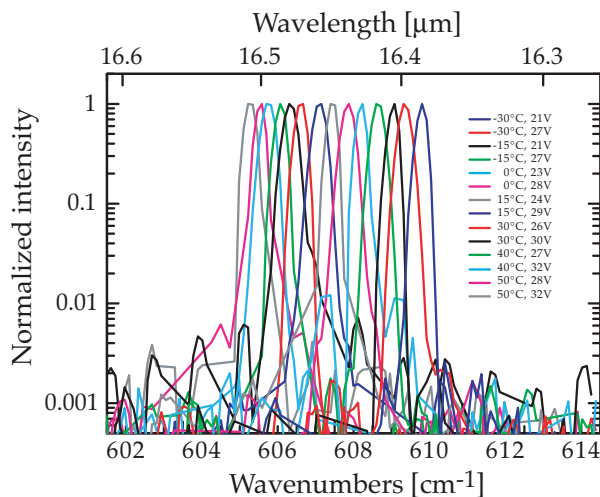

Characteristics

3mm-long, 44 μm -wide laser
 $\lambda \approx 16.4 \mu\text{m}$

Single-mode emission:
 Side Mode Suppression Ratio > 25 dB
 (limited by the resolution of the FTIR)

Tuning range:
 $\Delta\nu = 4.5 \text{ cm}^{-1}$ at 608 cm^{-1} (0.7%)

(605.76 cm^{-1} (16.51 μm) at 50°C to
 610.30 cm^{-1} (16.38 μm) at -30°C)

How does a DFB tune?

How does a DFB tune?

Tuning always due to thermal drift

(carrier effects can be neglected!)

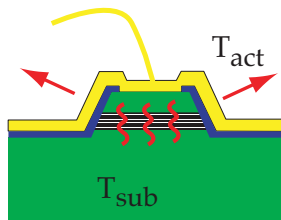

wavelength selection : $\lambda = 2 \cdot n_{\text{eff}} \cdot \Lambda_{\text{grating}}$

$$n_{\text{eff}} = n_{\text{eff}}(T)$$

$$\frac{d\lambda}{\lambda} = \frac{dn_{\text{eff}}}{n_{\text{eff}}}$$

How does a DFB tune?

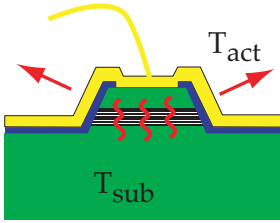

Active region heating:

$$T_{act} = T_{sub} + I \cdot U \cdot \delta \cdot R_{th} (+ I_{DC} U_{DC} \cdot R_{th})$$

$$\Delta T = T_{act} - T_{sub}$$

- If $\Delta T = 100^\circ\text{C}$ \Rightarrow 100% chance of laser-destruction (thermal stress)
- = 60°C \Rightarrow depends of mounting / laser -> dangerous
- = 30°C \Rightarrow OK

Different possibilities of thermal tuning: }

- substrate temperature
- additional bias current
- pulse length (chirping)
- pulse current
- duty-cycle

Tuning by changing T_{sub} (heatsink temperature)

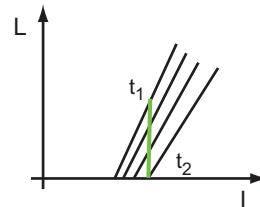
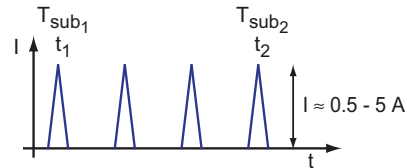
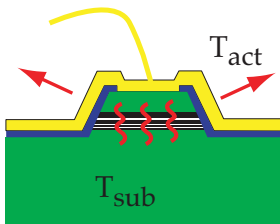

tuning coefficient :

$$\frac{1}{\lambda} \frac{\Delta \lambda}{\Delta T_{sub}} = \frac{1}{n_{eff}} \frac{\Delta n_{eff}}{\Delta T_{sub}} \approx [6 - 7] \cdot 10^{-5} \text{ K}^{-1}$$

$\Delta T \approx 60^\circ\text{C} \Rightarrow -0.4\% \Delta v/v @ 0.01\text{Hz}$

Tuning by DC bias-induced heating

by DC bias-induced heating

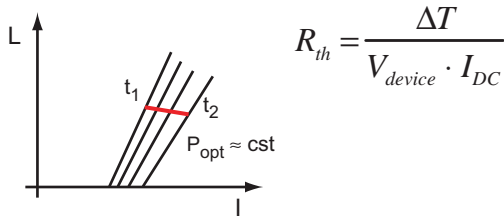
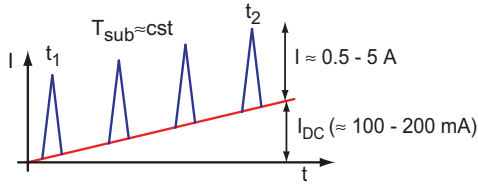

$$R_{th} = \frac{\Delta T}{V_{device} \cdot I_{DC}}$$

$\Delta T \approx 30^\circ\text{C} \Rightarrow -0.2\% \Delta v/v @ >1\text{kHz}$

by changing T_{sub}

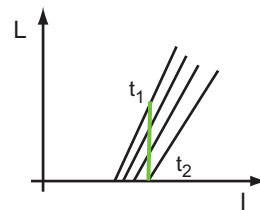
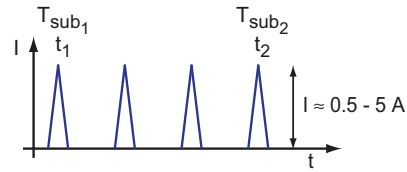

$\Delta T \approx 60^\circ\text{C} \Rightarrow -0.4\% \Delta v/v @ 0.01\text{Hz}$

Thermal chirping during pulse

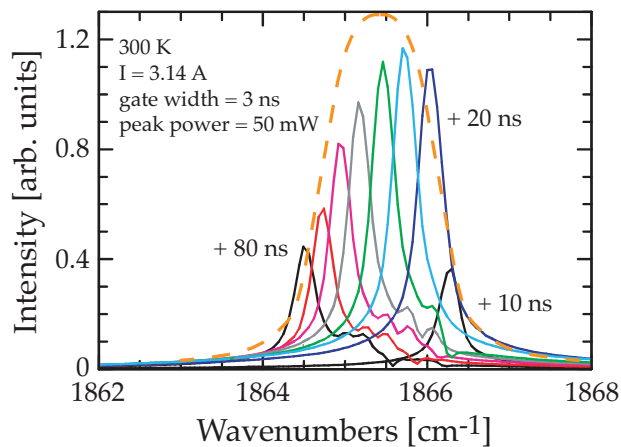

drift with time: $0.03 \text{ cm}^{-1}/\text{ns}$
(high dissipated power)

20 K temperature increase of
during a 100-ns-long pulse

Faist et al., Appl. Phys. Lett. 70, p.2670 (1997)

Pulse length dependence of linewidth

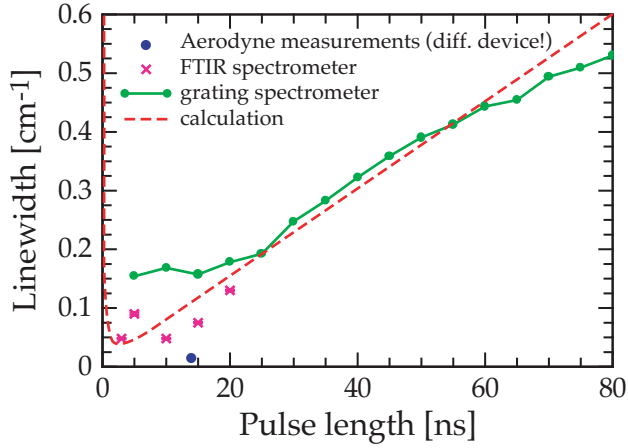

Need for a good compromise:

- too long: limited by thermal chirping
- too short: limited by the time evolution of the lasing mode

- ➔ fundamental limits
- ➔ for narrower linewidth: cw operation

Hofstetter et al., Opt. Lett. 26, p.887 (2001)

CW operation at $\lambda \approx 6.73\mu\text{m}$

LN2-CW-DFB-100-1485

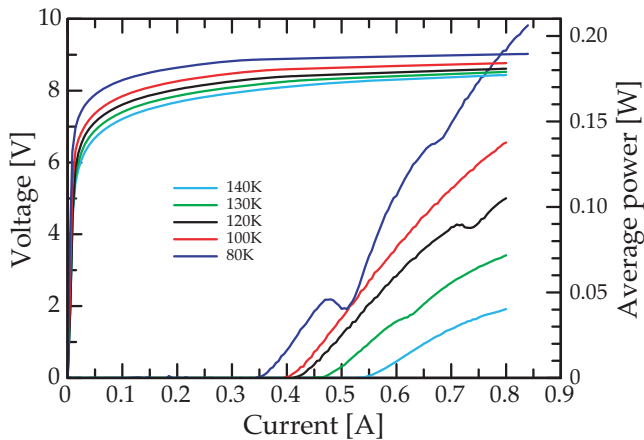

Characteristics

1.5 mm-long, 23 μm -wide laser
CW operation at $\lambda \approx 6.73\mu\text{m}$

@80 K: Average power $P = 0.2\text{ W}$
Threshold current:
 $I_{\text{th}} = 0.35\text{ A}$ ($j_{\text{th}} = 1.0\text{ kA/cm}^2$)

$I_{\text{op}} < 0.8\text{ A}$
 $U_{\text{op}} < 9\text{ V}$

CW operation at $\lambda \approx 6.73\mu\text{m}$

LN2-CW-DFB-100-1485

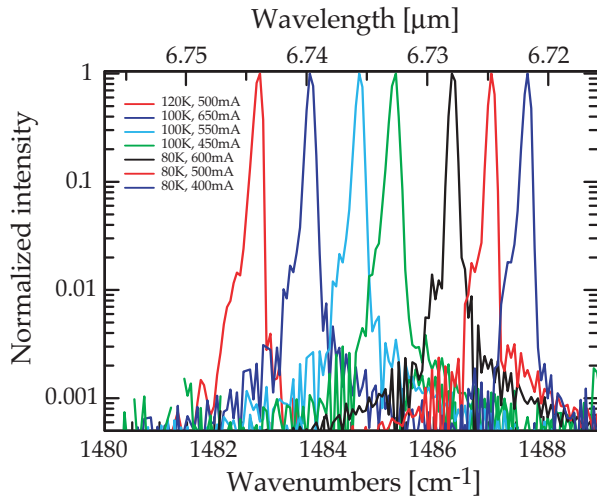

Characteristics

1.5 mm-long, 23 μm -wide laser
 CW operation at $\lambda \approx 6.73 \mu\text{m}$

Single-mode emission:
 Side Mode Suppression Ratio > 30 dB
 (limited by the resolution of the FTIR)

Tuning range:
 $\Delta\nu = 4.9 \text{ cm}^{-1}$ at 1485 cm^{-1} (0.33%)

(1482.8 cm^{-1} ($6.744 \mu\text{m}$) at 120K to
 1487.7 cm^{-1} ($6.722 \mu\text{m}$) at 80K)

CW operation at $\lambda \approx 4.60\mu\text{m}$

LN2-CW-DFB-10-2171

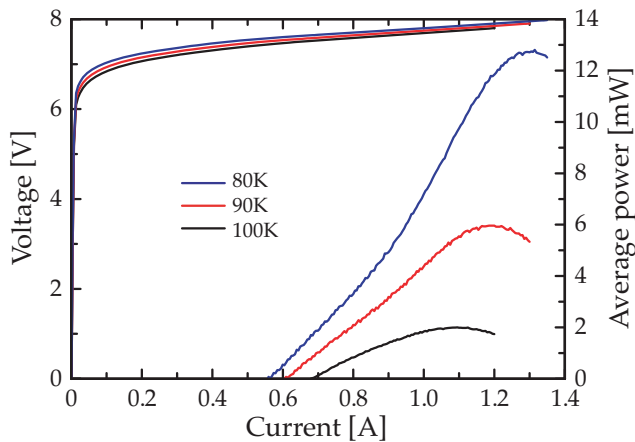

Characteristics

1.5 mm-long, 21 μm -wide laser
 CW operation at $\lambda \approx 4.60 \mu\text{m}$

@80 K: Average power $P = 12 \text{ mW}$
 Threshold current density:
 $I_{\text{th}} = 0.54 \text{ A}$ ($J_{\text{th}} = 1.7 \text{ kA/cm}^2$)

$I_{\text{op}} < 1.1 \text{ A}$
 $U_{\text{op}} < 8 \text{ V}$

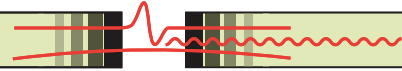

CW operation at $\lambda \approx 4.60\mu\text{m}$

LN2-CW-DFB-10-2171

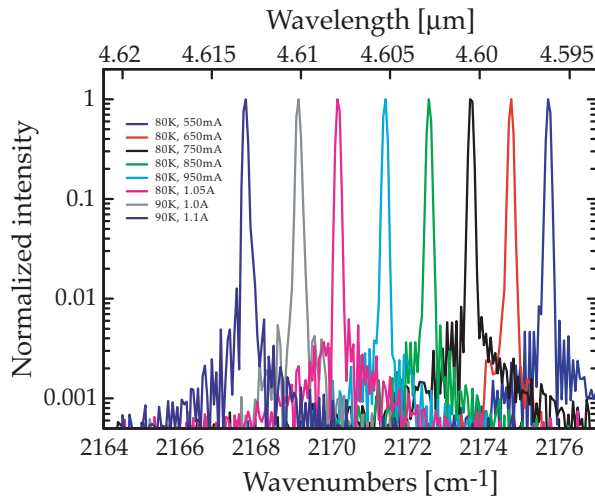

Characteristics

1.5 mm-long, 21 μm -wide laser
CW operation at $\lambda \approx 4.60\mu\text{m}$

Single-mode emission:
Side Mode Suppression Ratio > 25 dB
(limited by the resolution of the FTIR)

Tuning range:
 $\Delta\nu = 8\text{ cm}^{-1}$ at 2171 cm^{-1} (0.37%)

(2167.7 cm^{-1} ($4.613\mu\text{m}$) at 90K to
 2175.7 cm^{-1} ($4.596\mu\text{m}$) at 80K)

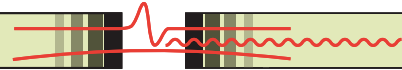

Future:

continuous-wave and single-mode operation at room-temperature

terahertz sources

Continuous-wave FP QCL on Peltier

RT-CW-FP-50-1080

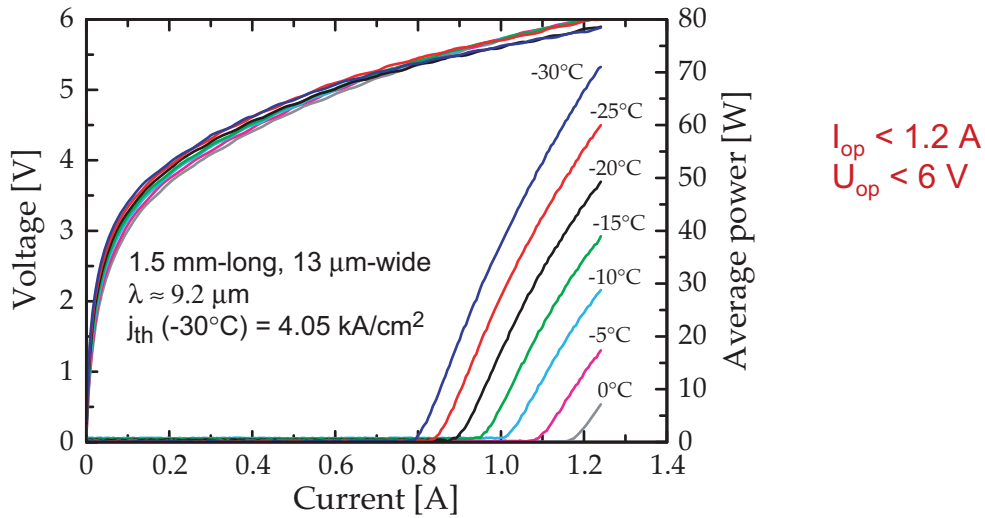

BH distributed-feedback QCLs

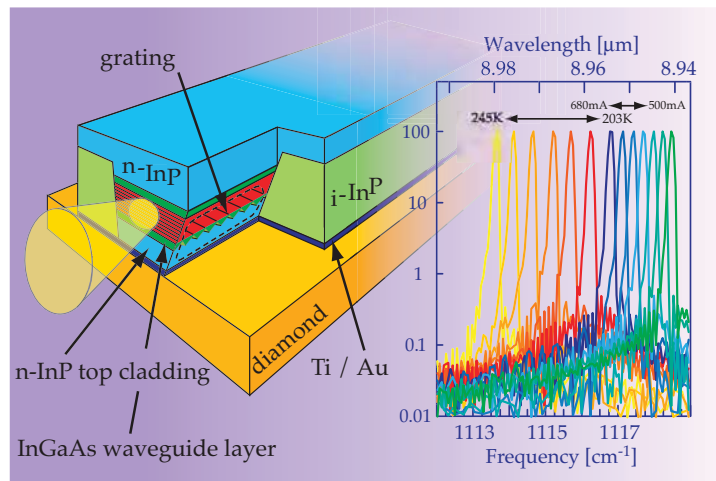

Continuous-wave distributed-feedback quantum-cascade lasers on a Peltier cooler. T. Aellen, S. Blaser, M. Beck, D. Hofstetter, J. Faist, and E. Gini, Appl. Phys. Lett. **83**, p.1929, 2003.

THz applications

New sources: R. Köhler et al., Nature 417, p.156, 2002.
 M. Rochat et al., Appl. Phys. Lett. 81 (8), p.1381, 2002.

Terahertz applications:

- Astronomy
- Medical imaging
- Chemical detection
- Telecommunications for local area network (LAN)

Terahertz sources

THz QC laser based on a bound to continuum design, $\lambda \approx 87 \mu\text{m}$
 Structure grown at University of Neuchâtel (G. Scalari, L. Ajili, M. Beck and M. Giovannini)

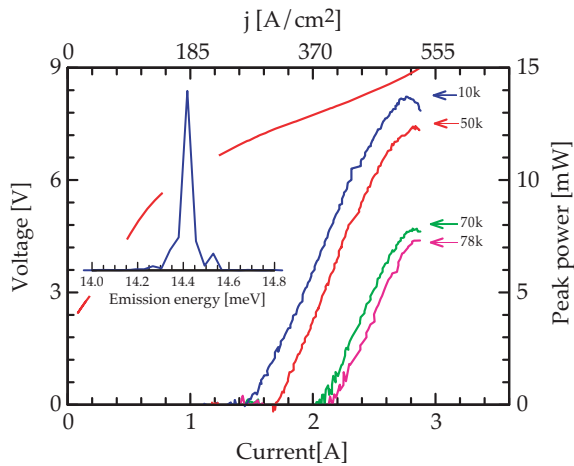

Characteristics

THz QC laser: $\lambda \approx 87 \mu\text{m}$
 2.7mm-long, 200 μm -wide laser
 back-facet coated

@10 K: Peak power (2.5% dc):
 P = 14 mW
 threshold current density:
 $j_{th} = 267 \text{ A/cm}^2$

pulsed operation up to 78K
 CW operation up to 30 K

Reliability of the devices

Reliability of the devices: ageing

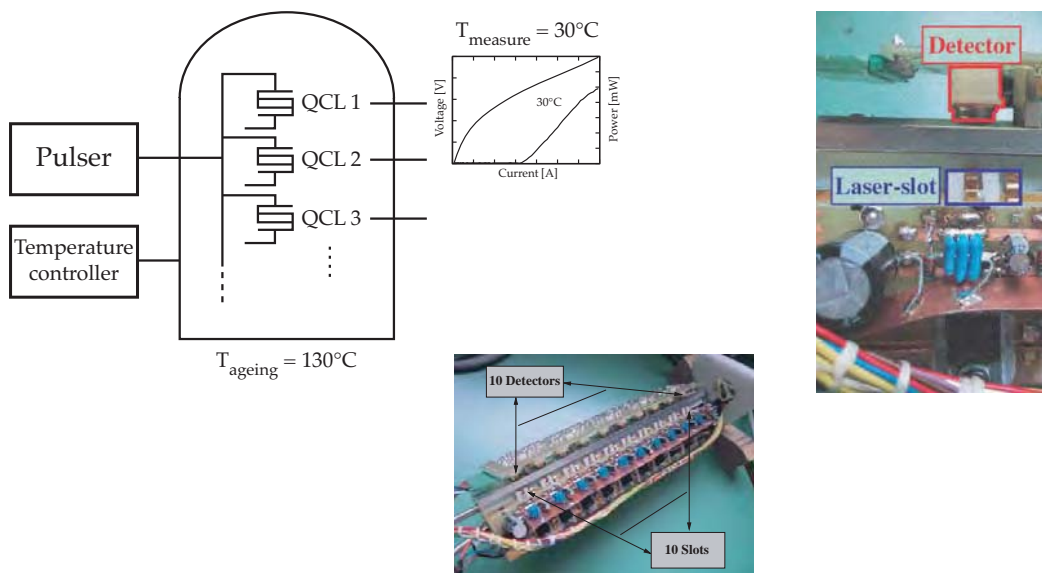

Ageing: theory

Conversion of lifetime using Arrhenius type relation: $t \sim \exp[E/(kT)]$

where: t is lifetime

T temperature

$E=0.7$ eV activation energy [H. Ishikawa et al., J. Appl. Phys. **50**, 1979]

(needs to be evaluated for QCL)

The room temperature lifetime t_1 (at $T_1 = 20^\circ\text{C}$ and 70% of initial power) can be extrapolated by :

$$t_1 = t_0 \cdot e^{\frac{E}{k} \cdot \frac{1}{T_1} - \frac{1}{T_0}}$$

with t_0 is the measured lifetime at the ageing temperature T_0 (here $130^\circ\text{C} = 403\text{K}$).

(using 100°C for example it will take 5 times longer)
 80°C 17

Ageing at 130°C : results

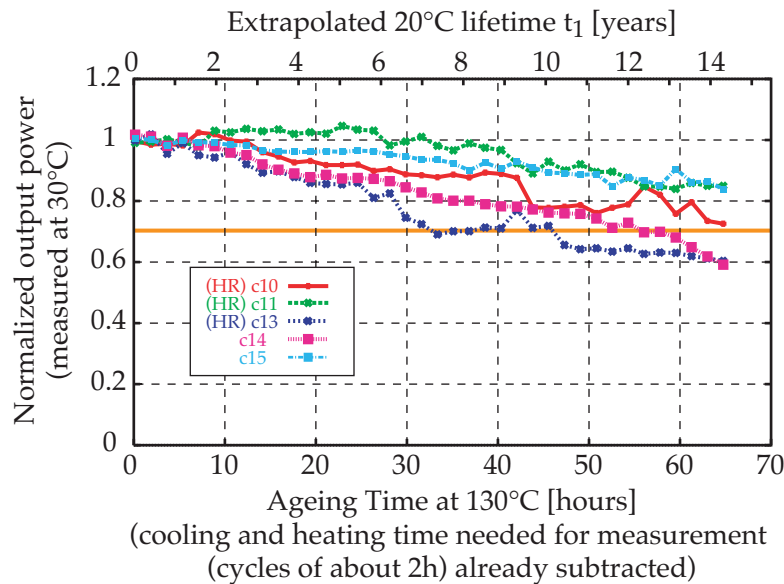

Production

Production line

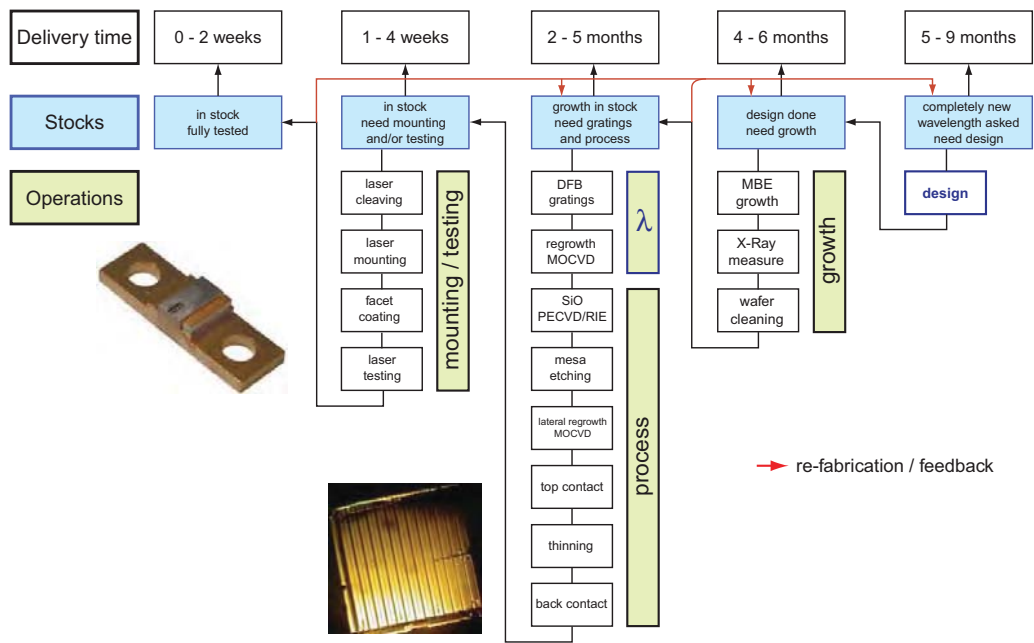

Production - lasers off the shelf

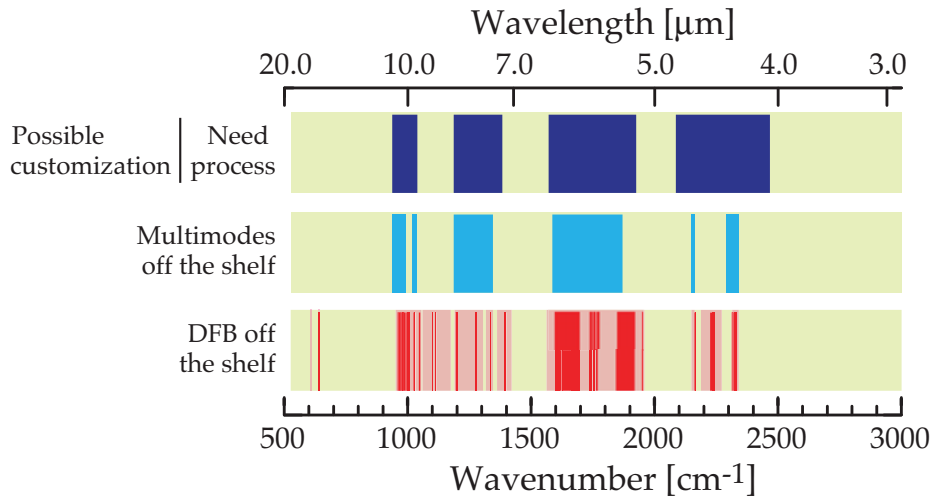

for an up to date wavelength listing, contact us at: <http://www.alpeslasers.ch>

List of products - prices

Type	Duty-cycle	Operating temp.	Product name	Power	Linewidth	Tunability	Off the shelf	Built to order	100+
DFB	pulsed	RT	RT-HP-DFB-2-X	> 2 mW	< 330 MHz	0.4%	11 kEUR	28 kEUR	
			RT-HP-DFB-5-X	> 5 mW			13.5 kEUR		
	cw	LN ₂	LN2-CW-DFB-2-X	> 2 mW	< 3.5 MHz	0.4%	23.5 kEUR	50 kEUR	
		RT	RT-CW-DFB-2-X	> 2 mW	< 3.5 MHz	0.4%	available end 2004		
FP	pulsed	RT	RT-HP-FP-10-X	> 10 mW	1 - 4 %	N/A	6 kEUR		
	pulsed	LN ₂	LN2-HP-FP-150-X	> 150 mW	1 - 4 %	N/A	20 kEUR		
	cw	RT	RT-CW-FP-5-X (only at 9.1 μm)	> 5 mW	1 - 4 %	N/A	17 kEUR		

<http://www.alpeslasers.ch>

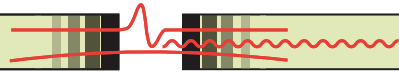

Conclusion / outlook

Available products

- pulsed DFB QCL on Peltier cooler in the range of 4.3 μm to 16.5 μm
- LN₂ continuous-wave DFB QCL in the range of 4.6 μm to 10 μm
- continuous-wave FP on Peltier cooler at 9.1 μm

Soon available

- THz sources (LN₂)

Available end 2004

- continuous-wave DFB on Peltier cooler
(already demonstrated: T. Aellen, S. Blaser, M. Beck, D. Hofstetter, J. Faist, and E. Gini, Appl. Phys. Lett. **83**, p.1929, 2003)

6300 SERIES

COMBOSOURCE DUAL RANGE LASER DRIVER + TEMPERATURE CONTROLLER



The 6300 Series ComboSource is a high-accuracy laser driver combined with a 60W temperature controller. With unique operational modes and safety features not found in other devices, this instrument is ideal for low and medium-power laser and LED applications.



DUAL RANGE LASER DRIVER

Operates at half-scale for improved resolution and lower noise.



OVERLAPPING LASER PROTECTION

Including safety interlock, ESD protection, hardware limits for current & voltage, soft power-on, and intermittent contact safeguards



MULTIPLE OPERATING MODES

Choose from: ● Constant Current ● Constant Power ● Constant Voltage



REMOTE VOLTAGE SENSING

Supports an extra pair of sensing wires to measure the operating voltage of your laser diode or LED.



AUTO-TUNE AND MANUAL PID SELECTION

One button auto-tunes your control loop, or choose from 8 factory gain settings, or select your own.



POWERFUL TEMPERATURE CONTROLLER

Supplies up to 60 Watts of TEC control and up to ± 0.004 °C. Works with a thermistor, LM-335, AD-590, or an RTD.



HIGH CONTRAST VFD MULTI-VIEW DISPLAY

View All 4 At Once: ● Laser Current & Voltage ● Photodiode Current
● Actual & Temp Set Point ● TEC Voltage & Current

AT-A-GLANCE

Current/Voltage Ranges

- ▷ 100 mA / 10 Volt
- ▷ 500 mA / 10 Volt
- ▷ 1 Amp / 10 Volt
- ▷ 4 Amp / 5 Volt

High Accuracy

- ▷ Up to 0.025% of reading + 0.025% of scale

Low Noise

- ▷ As low as <1 μ A

Superb Temperature Stability

- ▷ ± 0.004 °C (over 1 hour)
- ▷ ± 0.01 °C (over 24 hours)

Remote Operation via PC

- ▷ Use your existing control code. Our command set is compatible with other manufacturers.
- ▷ USB / RS-232 Connections



GROUND LOOPS: ELIMINATED. YOUR LASER IS PROTECTED.

A ground loop can destroy your laser in an instant. Every input and control circuit on the ComboSource is electrically isolated. Offset voltages, ground connections, and AC noise will never act on your system.

No other laser driver on the market has this capability.

6300 LASER SPECIFICATIONS

		6301	6305	6310	6340					
Laser	Setpoint	Laser Current								
		Range (mA)	0-50	0-100	250	500	500	1000	2000	4000
		Max Resolution (mA)	0.002	0.005	0.01	0.02	0.02	0.05	0.1	0.2
		Accuracy (\pm [% set+mA])	0.025% + 0.02	0.025% + 0.03	0.025% + 0.08	0.025% + 0.12	0.025% + 0.12	0.025% + 0.3	0.025% + 0.5	0.05% + 0.8
		Stability (ppm, time)	< 10, 1 hour							
		Temperature Coeff (ppm/ $^{\circ}$ C)	50							
		Noise/Ripple (μ A rms)	< 1	< 1.2	< 1.5	< 1.5	< 2.5	< 35	< 40	
		Transients (μ A)								
		Compliance Voltage (V)	10	10	10	10	10	10	5	
		Photodiode Current								
	Range (μ A)	2 – 5,000								
	Resolution (μ A)	0.1								
	Accuracy (\pm [% set+ μ A])	0.05% + 1								
	Stability (ppm, time)	< 200, 24 hours								
	Temperature Coeff (ppm/ $^{\circ}$ C)	< 200								
	PD Bias (V)	0 to -5V, programmable								
	Laser Voltage									
	Range (V)	0 – 10	0 – 10	0 – 10	0 – 10	0 – 10	0 – 10	0 – 5		
	Resolution (V)	0.001								
	Accuracy (\pm [% set+V])	0.05% + 0.005								
Stability (ppm, time)	< 50, 1 hour									
Temperature Coeff (ppm/ $^{\circ}$ C)	< 100									
External Modulation										
Input Range	0 – 10V, 10k Ω									
Modulation Bandwidth (kHz)	325	325	325	200	200	200	150			
Measurement	Laser Current									
	Resolution (mA)	0.002	0.005	0.01	0.02	0.02	0.05	0.1	0.2	
	Accuracy (\pm [% set+mA])	0.025%+ 0.02	0.025%+ 0.03	0.025%+ 0.08	0.025%+ 0.12	0.025%+ 0.12	0.025%+ 0.3	0.025%+ 0.5	0.05%+ 0.8	
	Laser Voltage									
	Resolution (V)	0.001								
	Accuracy (\pm [% read+V])	0.05% + 0.005								
Limits	Photodiode Current									
	Resolution (μ A)	0.1								
	Accuracy (\pm [% read+ μ A])	0.05% + 0.5								
Laser Current										
Resolution (mA)	1									
Accuracy (\pm mA)	2	5	5	10	10	10	40			
Laser Voltage										
Resolution (V)	0.1									
Accuracy (\pm % FS)	2.5%									

www.arroyoinstruments.com



arroyo instruments

800-644-0416

624 Clarion Court, San Luis Obispo, CA 93401

sales@arroyoinstruments.com

6300 TEC SPECIFICATIONS

	6301	6305	6310	6340	
TEC	Setpoint	Temperature			
		Range (°C) ¹	-99 to 250		
		Resolution (°C)	0.01		
		Therm Accuracy (± °C) ²	0.05 ³		
		AD560 Accuracy (± °C) ²	0.05		
		LM335 Accuracy (± °C) ²	0.05		
		RTD Accuracy (± °C) ²	0.05		
		Stability (1hr) (± °C) ⁴	0.004		
		Stability (24hr) (± °C) ⁴	0.01		
	Current				
	Range (A)	5			
	Compliance Voltage (V)	12			
	Max Power (W)	60			
	Resolution (A)	0.01			
	Accuracy (± [% set+mA])	0 + 30			
	Noise/Ripple (mA, rms)	< 5			
	Measurement	Current			
Resolution (mA)		10			
Accuracy (± [% read+mA])		0 + 30			
Voltage					
Resolution (mV)		10			
Accuracy (± [% read Volts])		0 + 0.05			
10µA Thermistor					
Range (kΩ)		0.2 – 450			
Resolution (kΩ)		0.01			
Accuracy (± [% read+kΩ])		0.05 + 50			
100µA Thermistor					
Range (kΩ)		0.02 – 45			
Resolution (kΩ)		0.001			
Accuracy (± [% read+kΩ])		0.05 + 5			
LM335					
Bias (mA)		1			
Range (mV)		1730 – 4730			
Resolution (mV)		0.1			
Accuracy (± [% read+mV])		0.3 + 1			
AD590					
Bias (V)		4.5			
Range (µA)	173 – 473				
Resolution (µA)	0.01				
Accuracy (± [% read+ µA])	0.03 + 0.1				
RTD					
Range (Ω)	20 – 192				
Resolution (Ω)	0.01				
Accuracy (± [% read+Ω])	0.03 + 0.1				
Limits	Laser Current				
	Resolution (mA)	10			
	Accuracy (mA)	40			
General	Display Type	4x20 VFD			
	Laser Connector	DB-9, female			
	TEC Connector	DB-15, female			
	Fan Supply	4 – 12V, 350mA max			
	Computer Interface	USB 2.0 Full Speed (Type B), RS-232 (DB-9, male)			
	Power	100V / 120V / 230V, 50/60 Hz			
	Size (H x W x D) [inches (mm)]	3.47 (89) x 8.5 (215) x 12 (305)			
	Weight [lbs (kg)]	7.8 (3.5)			
	Operating Temperature	+10°C to +40°C			
	Storage Temperature	-20°C to +60°C			

1. Software limits. Actual range dependent on sensor type and system dynamics.
2. Accuracy figures are the additional error the 5300 adds to the measurement, and does not include the sensor uncertainties.
3. 25°C, 100µA thermistor.
4. Stability measurements done at 25°C using a 10kΩ thermistor on the 100µA setting. The number is ½ the peak-to-peak deviation from the average over the measurement period.

www.arroyoinstruments.com

REAR VIEW

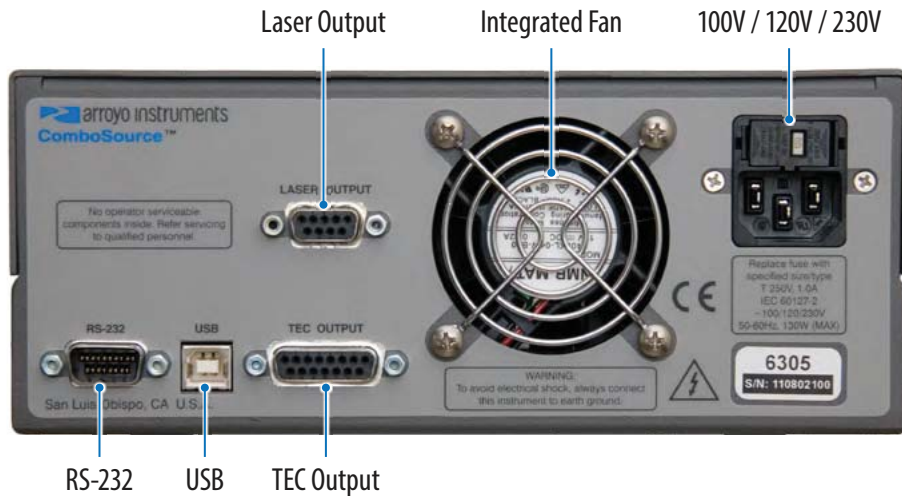

ARROYO CONTROL



Control any Arroyo laser driver or temperature controller directly from your PC. Simply connect to your Arroyo device via USB or RS-232 and gain direct access to settings, device limits, and adjustments from an easy-to-use Windows interface. You can even connect to multiple instruments at the same time.

Download ArroyoControl for free from www.arroyoinstruments.com.

LabView drivers available.



ACCESSORIES



1401-RM-1

6300 SERIES 2U RACK MOUNT KIT, 1 UNIT

This rack mount kit will mount any 6300 ComboSource, 5300 Series TECSource, or 4300 Series LaserSource in 2U of rack space. The unit can be positioned to the left or right side of the rack space, depending on how you mount the hardware.



1401-RM-2

6300 SERIES 2U RACK MOUNT KIT, 2 UNITS

This rack mount kit will mount any 6300 ComboSource, 5300 Series TECSource, or 4300 Series LaserSource side-by-side in 2U of rack space.

www.arroyoinstruments.com



arroyo instruments

800-644-0416

Accessories for use with Alpes Lasers

In an instrument

For a QCL in Alpes TO-3 or HHL package

- Arroyo 6310-QCL Laser Driver and TE Cooler Controller combo instrument
- Thermally conductive heat sink of customer design is valid as long as thermal conductance is sufficient; bolt the package to instrument structure with or without additional heat dispersing elements like radiators or fans.
- Cables from 6310-QCL to HHL: use p/n C0326, 2 meter with HHL 10 pin on one end bifurcated to connectors for TEC and laser driver on 6310-QCL end(s).
- Cables from 6310-QCL to TO-3: use p/n 1221B, 2 meter with pigtailed to solder to TO-3 or socket on one end and 6310-QCL laser driver connector on other end AND use p/n 1261B, 2 meter with pigtailed to solder to TO-3 or socket on one end and 6310-QCL TEC connector on other end
- TO-3 socket is available as p/n C0222



Figure 1, TO-3

In the laboratory

For TO-3 packaged lasers, a PASSIVE heat sink normally works

- Arroyo 6310-QCL Laser Driver and TE Cooler Controller
- 1220B LaserSource Cable
- 1260B TECSOURCE Cable
- 246 TO-3 LaserSource Mount

For HHL packaged lasers, a PASSIVE heat sink

- Arroyo 6310-QCL Laser Driver and TE Cooler Controller
- 1220B LaserSource Cable
- 1260B TECSOURCE Cable
- 244 HHL LaserSource Mount

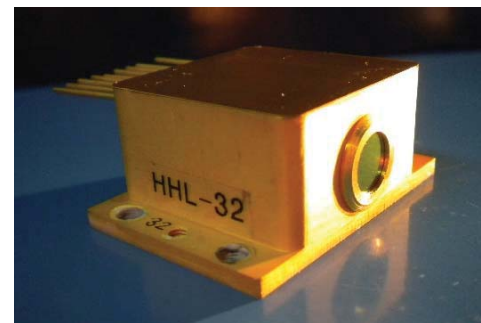

Figure 2, HHL

This should provide HHL operation to -10C, possibly lower.

For LLH housings, use

- Alpes Pulsed Starter Kit with TC-3 cooler controller and S-2 laser pulser for PULSED QCLs [includes cables]
- For CW QCLs, use Alpes TC-3 cooler controller and the Arroyo 4200-01-18-DR driver [cables will be supplied]

To operate the HHL at even lower temperatures, you have two options:

1. Arroyo 286-01 – TE cooled sink with additional air-cooling, but rather large. A photo is below shows the cold plate, along with the options for mounting the HHL device: Nearly \$3000 more expensive than the 244 set up

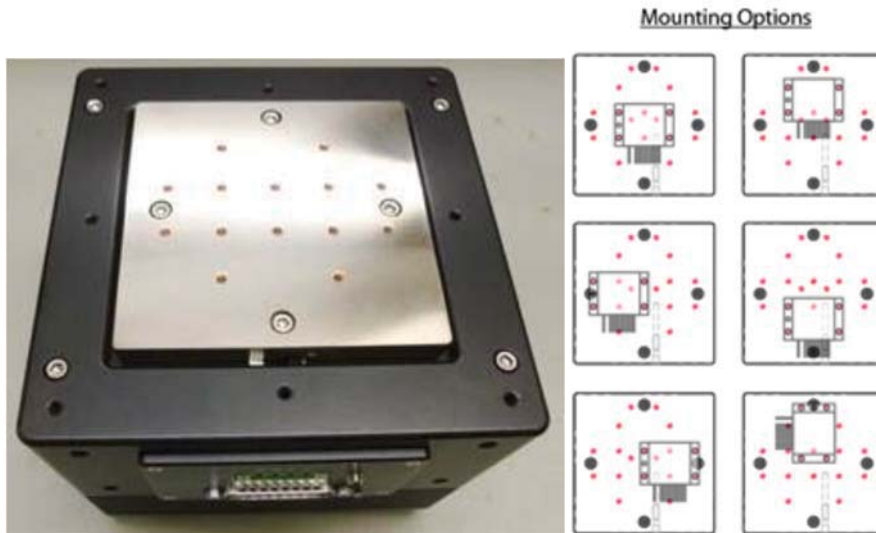

2. Arroyo 274 – TE cooled sink with additional water cooling, much smaller. We have an adapter plate with the mounting holes for the HHL laser so it can be fitted to the 274. About \$1200 more expensive than the 244 set up and needs water.



Both of these options would require different cable sets, specifically the C0326, "LaserSource/TECSource Cable, HHL, 2m. This is a "Y" cable with a HHL connector on one end and the laser/TEC connectors on the other end. It would also require a second TEC controller, the 5305 for this application, that would provide more than enough TEC power to maintain the HHL base temperature.



APPLICATIONS

Fields of applications:

Quantum cascade lasers have been proposed in a wide range of applications where powerful and reliable mid-infrared sources are needed. Examples of applications are:

Industrial process monitoring:

Contamination in semiconductor fabrication lines, food processing, brewing, combustion diagnostics.

Life sciences and medical applications

Medical diagnostics, biological contaminants.

Law enforcement

Drug or explosive detection.

Military

Chemical/biological agent detection, counter measures, covert telecommunications.

Why the mid-infrared?

Because most chemical compounds have their fundamental vibrational modes in the mid-infrared, spanning approximately the wavelength region from 3 to 15 μm , this part of the electromagnetic spectrum is very important for gas sensing and spectroscopy applications. Even more important are the two atmospheric windows at 3-5 μm and 8-12 μm . The transparency of the atmosphere in these two windows allows remote sensing and detection. As an example, here are the relative strengths of CO₂ absorption lines as a function of frequency:

Wavelength (μm)

1.432

1.602

Relative
absorption
strength

1

3.7

2.004	243
2.779	6800
4.255	69000

Approximate relative line strengths for various bands of the CO₂ gas.

Moreover, because of the long wavelength, Rayleigh scattering from dust and rain drops will be much less severe than in the visible, allowing applications such as radars, ranging, anti-collision systems, covert telecommunications and so on. As an example, Rayleigh scattering decreases by a factor 10⁴ between wavelengths of 1µm and 10µm.

Detection techniques

Direct absorption

In a direct absorption measurement, the change in intensity of a beam is recorded as the latter crosses a sampling cell where the chemical to be detected is contained. This measurement technique has the advantage of simplicity. In a version of this technique, the light interacts with the chemical through the evanescent field of a waveguide or an optical fiber.

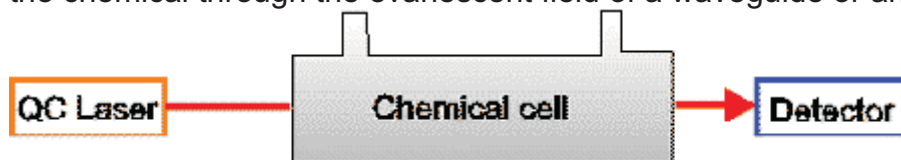

Some examples of use a direct absorption technique:

- [A. Müller et al. 1999 \(PDF 1187kB\)](#)
- B. Lendl et al.

Frequency modulation technique (TILDAS)

In this technique, the frequency of the laser is modulated sinusoidally so as to be periodically in and out of the absorption peak of the chemical to be detected. The absorption in the cell will convert this FM modulation into an AM modulation, which is then detected usually by a lock-in technique.

TILDAS DETECTION TECHNIQUE

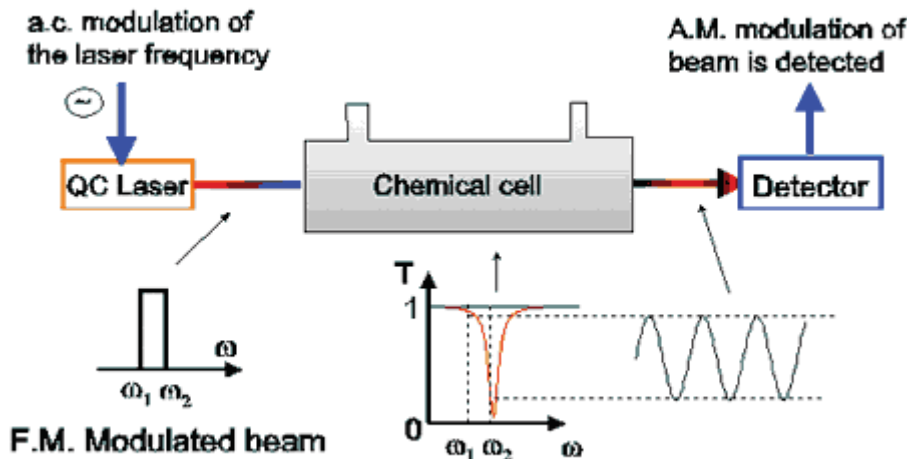

The absorption converts F.M. in A.M modulation

The advantage of the TILDAS technique is mainly its sensitivity. First of all, under good modulation condition, an a.c. signal on the detector is only present when there is absorption in the chemical cell. Secondly, this signal discriminates efficiently against slowly varying absorption backgrounds. For this reason, this technique will usually work well for narrow absorption lines, requiring also a monomode emission from the laser itself. This technique has already been successfully applied with Distributed Feedback Quantum Cascade Laser (DFB-QCL). Some examples in the literature include:

- [E. Whittaker et al, Optics Letters 1998 \(PDF 229kB\)](#)
- F. Tittel et al., accepted for publication in Optics Letters.

Photoacoustic detection

In the photoacoustic technique, the optical beam is periodically modulated in amplitude before illuminating the cell containing the absorbing chemical. The expansion generated by the periodic heating of the chemical creates an acoustic wave, which is detected by a microphone. The two very important advantages of photoacoustic detection are

- a signal is detected only in the presence of absorption from the molecule
- no mid-ir detectors are needed.

For these reasons, photoacoustic detection has the potential of being both cheap and very sensitive. However, ultimate sensitivity is usually limited by the optical power of the source.

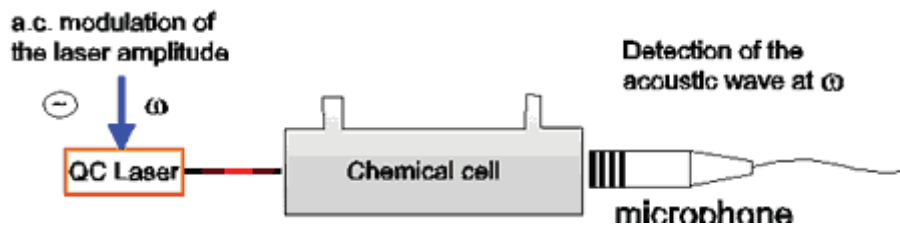

Photoacoustic detection has already been used successfully with unipolar laser, see

- Paldus et al., Optics Letters ...

Customers

Our list of customers includes:

[Jet Propulsion Laboratory](#) (USA), [Vienna University of Technology](#) (Austria), [Fraunhofer Institute](#) (Germany), [Georgia Institute of technology](#) (USA), [ETHZ](#) (Switzerland), [Physical Sciences Inc.](#) (USA): [first QCL based product](#), [Aerodyne](#) (USA), Scuola Normale de Pisa (Italy), Orbisphere (Switzerland).



TECHNOLOGY

General device characteristics

How do I drive the device?

As for any semiconductor laser, the performance of the device depends on the temperature. In general, unipolar lasers need (negative) operating voltage around 10 V with (peak-) currents between 1 and 5 A, depending on the temperature and the device. Around room temperature, that is the temperature range (-40..+70 °C) that can be reached by Peltier elements, unipolar lasers operate only in pulsed mode because of the large amount of heat dissipated in the device. In general, pulse length around 100 ns is suitable for Fabry Pérot devices. Alpes Lasers sells [electronic drivers](#) dedicated to unipolar lasers.

Electrical behavior and I-V characteristics

Quantum cascade lasers exhibit I-V curves that are diode like characteristics for short wavelength devices ($\lambda = 5 \mu\text{m}$) to almost ohmic behavior for $\lambda = 11 \mu\text{m}$. In any case the differential resistance at threshold is a few ohms. Long wavelength devices often exhibit a maximum current above which, if driven harder, the voltage increases abruptly while the optical power drops to zero. This process, which occurs only in unipolar lasers, is usually non-destructive and reversible if the device is not driven too hard above its maximum current.

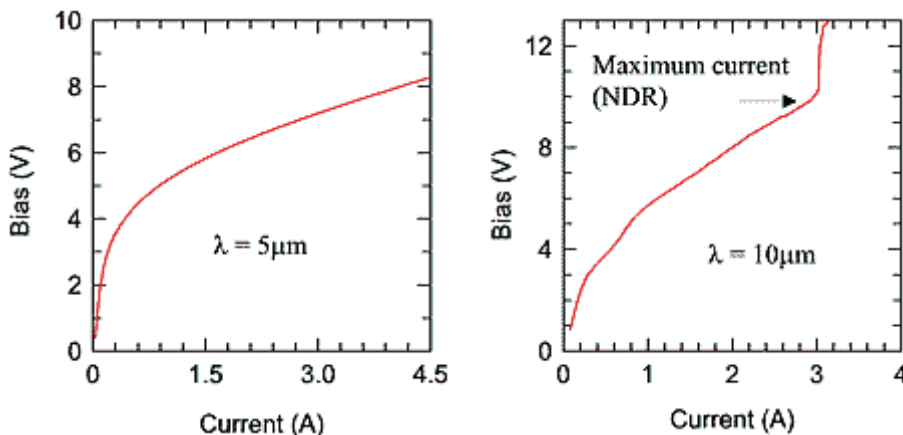

Room temperature I-V curves of unipolar lasers (measured in pulsed mode). The device operating at $\lambda = 10 \mu\text{m}$ has a maximum operation current (because of the appearance of Negative Differential Resistance or NDR) of 3.2 A.

Electrical model:

In a simplified way, the device can be modeled, for electronic purpose, by a combination of two resistors and two capacitors. As shown by the above I-V curves, R1 increases from 10 to 20 Ohms at low biases to 1-3 Ohms at the operating point. C1 is a 100-pF capacitor (essentially bias independent) between the cathode and the anode coming from the bonding pads. C2 depends on your mounting of the laser typically in the Laboratory Laser Housing, C1<100 pF

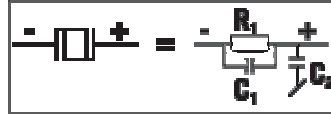

Temperature dependence of the laser characteristics:

The threshold current and slope efficiency are temperature dependent, although this dependence is much weaker than the one observed in interband devices at similar wavelengths. Shown below are a set of power versus current curves taken from a device $\lambda = 10 \mu\text{m}$ at various temperatures. In general, the device has a maximum operation temperature, which, depending on the design and wavelength, can be between 300K to a maximum of 400K. As maximum power and sometimes slope efficiencies both increase with decreasing temperature, it is usually advisable to cool the device with a Peltier element. Alpes Lasers sells a [special Peltier cooled housing](#) dedicated to driving unipolar lasers. Peak power between 20 and 100 mW, which is equal to average powers between 2 and 10 mW, are obtained typically.

High temperature pulsed operation

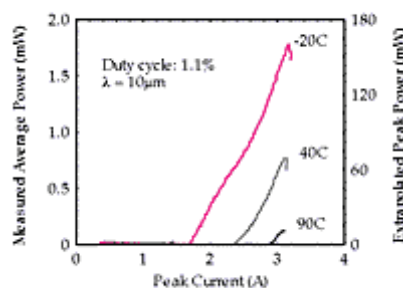

Extrapolated maximum operation temperature 105C

Peak and average power (at a duty cycle of 1.5%) for a unipolar laser as a function of temperature.

Peltier-cooled Fabry-perot QC laser

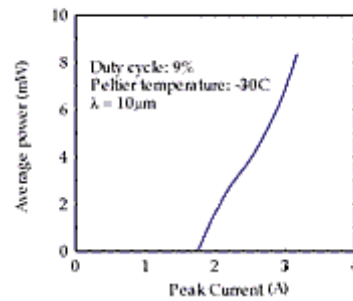

High duty cycle operation of a unipolar laser

Typically, because of excess heat due to the driving current, unipolar lasers must be driven by current bursts with typically 10 ns rise time and a pulse-length of 100 ns. Some unipolar lasers may also operate in continuous wave (c.w.) at cryogenic temperatures, with a maximum operating temperature of 50 to 100 K depending on the design.

Alpes Lasers specify c.w. operation on special request.

Spectral characteristics

Under pulsed operation, the spectra of these lasers are multimode, the spectral width of the emission being of about one to fifty nanometer ($1\text{-}30\text{ cm}^{-1}$, typically 10 cm^{-1}) depending on the device design and operating point. Although it is not a property common to all unipolar laser designs, our long-wavelength devices will blue shift with increasing current, as shown on the figure below.

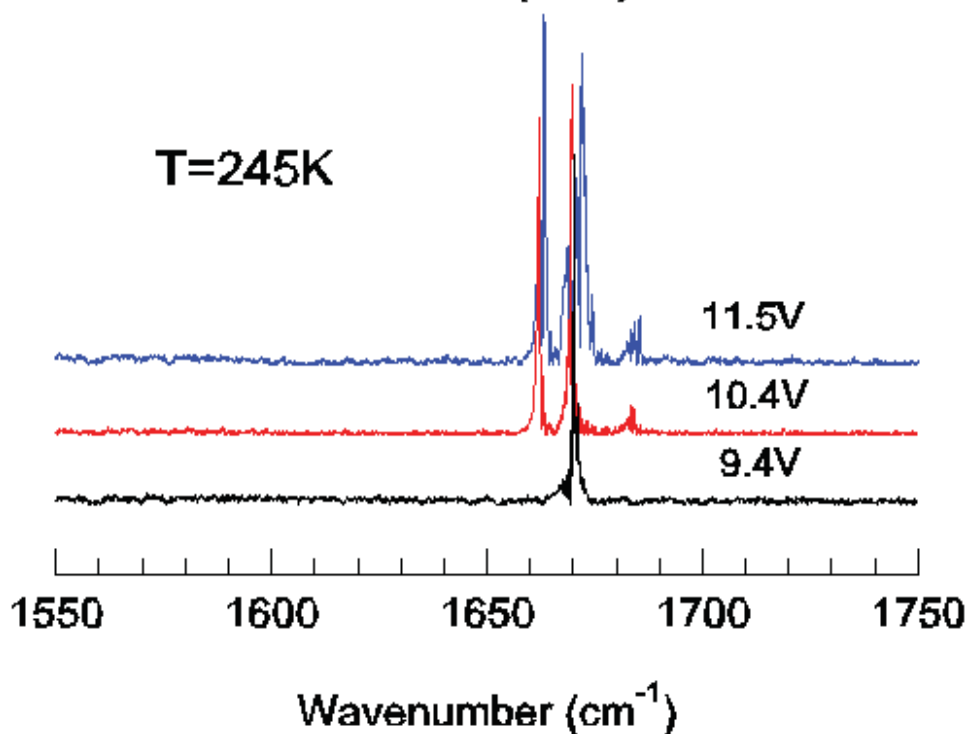
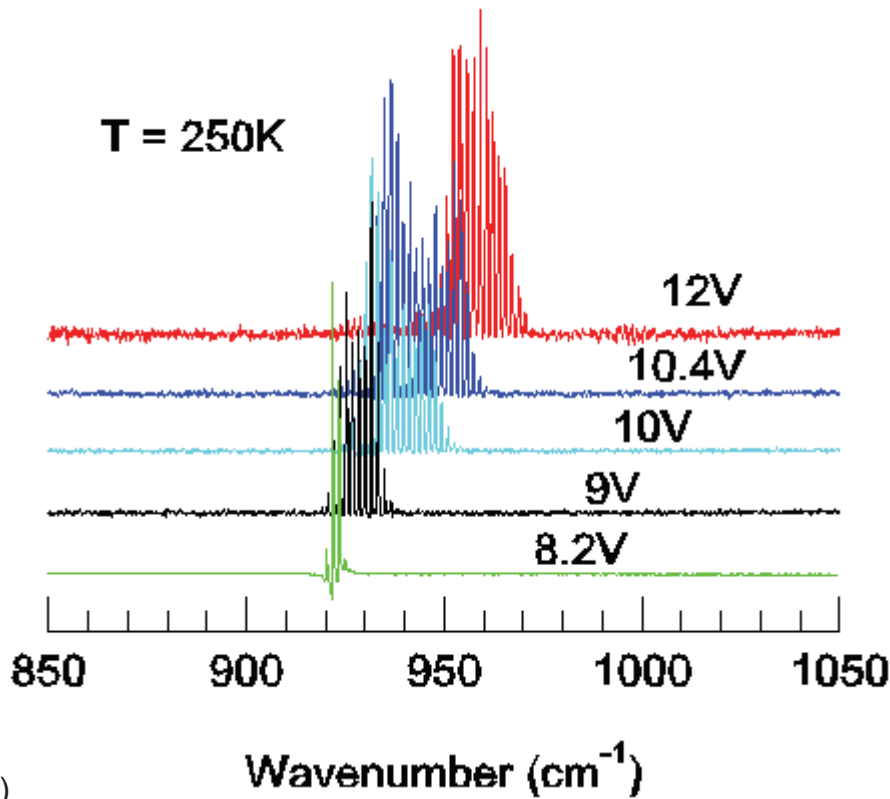

- a) spectra of a long wavelength laser based on a diagonal transition
 b) spectrum of a short wavelength laser based on a vertical transition

Electrical tuning

By driving the device with two different electrodes, wavelength and output power can be independently adjusted. Tuning ranges as large as 40 cm^{-1} at a peak power of 5 mW and a temperature of $-10 \text{ }^\circ\text{C}$ have been obtained by Alpes Lasers.

See [literature](#) for more details on this technique.

Distributed Feedback Laser (DFB)

In a Distributed Feedback Laser, a grating is etched into the active region to force the operation of the laser at very specific wavelength determined by the grating periodicity. As a consequence, the laser is single frequency which may be adjusted slightly by changing the temperature of the active region with a tuning rate of $1/n$ $Dn/DT = 6 \times 10^{-5} \text{ K}^{-1}$.

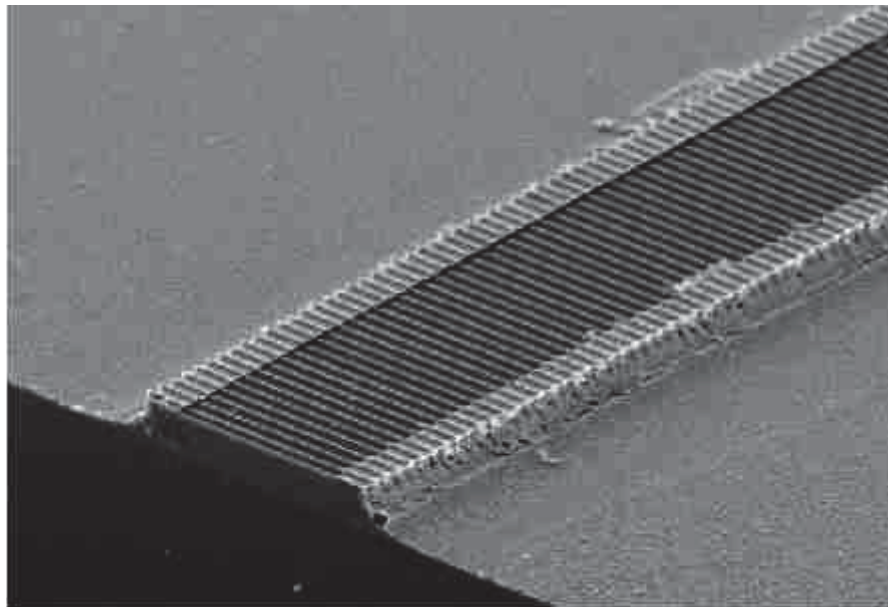

Scanning Micrograph image of a Distributed Feedback Unipolar Laser (DFB-UL).
The grating selecting the emission wavelength is well visible on the surface.

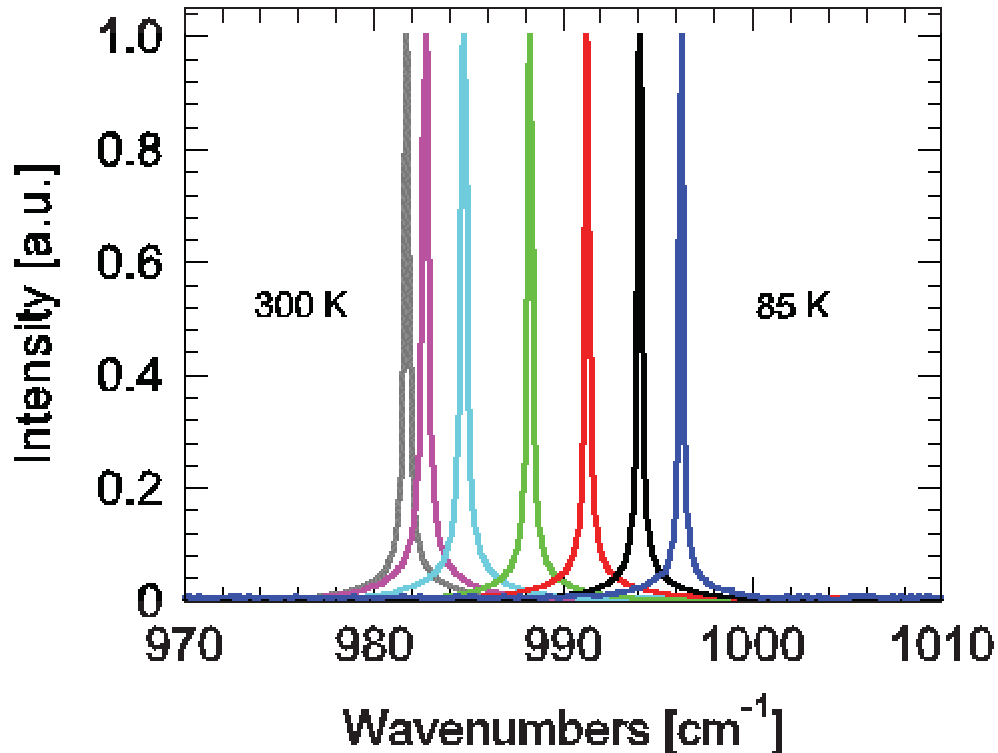

Emission spectra versus temperature for a DFB-UL. The device is driven at its maximum current.

It must be stressed that because of this tuning effect, when operated in pulsed mode close to room temperature, the linewidth of emission is a strong function of quality of electronics driving the laser. The latter should optimally deliver short pulses (best 1-10 ns to obtain the narrowest lines) with an excellent amplitude stability. The laser will drift at an approximate rate of a fraction of Kelvin per nanosecond during the pulse [\[see literature\]](#).

Beam Properties

Polarization

Because the intersubband transition exhibit a quantum mechanical selection rule, the emission from a unipolar laser is always polarized linearly with the electric field perpendicular to the layers (and the copper sub mount).

Beam divergence

The unipolar laser is designed around a tightly confined waveguide. For this reason, the beam diffracts strongly at the output facet and has a (full) divergence angle of about 60 degrees perpendicular to the layer and 40 degrees parallel to the layers

(see figures below). A #1 optics will typically collect about 70% of the emitted output power. Be careful that the collected output power will decrease with the square of the f-number of the collection optics. The mode is usually very close to a Gaussian 0,0 mode.

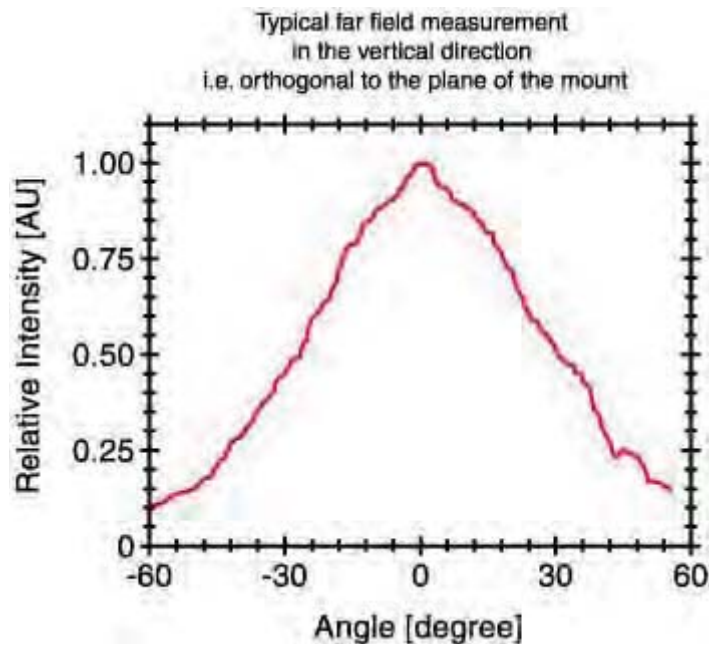
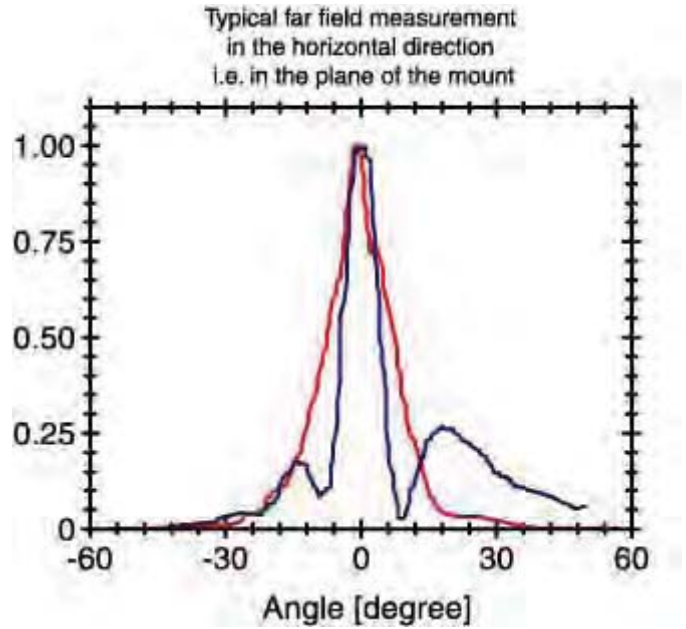



Scientific References

Review Papers

- Review of Scientific Instruments: V73, 6, (2002), S. Barbieri, J.-P. Pellaux, E. Studemann, D. Rosser, "Gas detection with quantum cascade lasers: An adapted photoacoustic sensor based on Helmholtz resonance" ([PDF128 kB](#))
- Applied Physics Letters: V78, 2, (2001), J. Faist, M. Beck, T. Aellen, E. Gini, "Quantum-cascade lasers based on a bound-to-continuum transition" ([PDF208kB](#))
- Proceedings Sensors Expo: Antoine Müller, M. Beck, J. Faist, R. Schindler, H. Ehmoser, B. Lendl and J.-P. Pellaux, Cleveland (USA), "Novel Quantum Cascade Laser Based Measurements of Chemicals in Liquid and Gases with 50 Fold Improved Signal to Noise Ratio" ([PDF1187 kB](#))
- Applied Physics Letters: V75, 11, (1999), A. Müller, Matthias Beck, Jérôme Faist, Ursula Oesterle and Marc Illegems, "Electrically tunable room-temperature quantum-cascade lasers" ([PDF53 kB](#))
- Applied Physics Letters: V75, 5, (1999), D. Hofstetter, J. Faist, M. Beck, A. Müller and U. Oesterle, "Demonstration of High-performance 10.16mm quantum cascade distributed feedback laser fabricated without epitaxial regrowth" ([PDF219 kB](#))
- Optics Letters, V23, 3, (1998), K. Namjou, S. Cai, E. A. Whittaker, J. Faist, C. Gmachl, F. Capasso, D.L. Sivco and A. Y. Cho, "Sensitive absorption spectroscopy with a room-temperature distributed-feedback quantum-cascade laser" ([PDF229 kB](#))

Recent Applications

- R. Lewicki, A. Kosterev, D. M. Thomazy, L. Gong, R. Griffin, T. Day, and F. K. Tittel, "Ammonia Sensor for Environmental Monitoring Based on a 10.4 μm External-Cavity Quantum Cascade Laser," in Laser Applications to Chemical, Security and Environmental Analysis, OSA Technical Digest Series (CD) (Optical Society of America, 2010), paper LTuD2.
<http://www.opticsinfobase.org/abstract.cfm?URI=LACSEA-2010-LTuD2>
- M. Geiser; C. Pflügl; A. Belyanin; Q. J. Wang; N. Yu; M. A. Belkin; T. Edamura; H. Kan; M. Fischer; A. Wittmann; J. Faist; Federico Capasso, "Surface-emitting THz sources based on difference-frequency generation in mid-infrared quantum cascade lasers (Proceedings Paper)", Novel In-Plane Semiconductor Lasers IX (Proceedings Volume) Proceedings of SPIE Volume: 7616.

- G. Scalari, M. I. Amanti, C. Walther, R. Terazzi, M. Beck, and J. Faist, "Broadband THz lasing from a photon-phonon quantum cascade structure," Opt. Express 18, 8043-8052 (2010)
<http://www.opticsinfobase.org/abstract.cfm?URI=oe-18-8-8043>
- Bismuto, A.; Terazzi, R.; Beck, M.; Faist, Jerome; "Electrically tunable, high performance quantum cascade laser", Applied Physics Letters, Apr 2010, Volume 96, Issue 14
- Antoine Müller & Jérôme Faist, "The quantum cascade laser: Ready for take-off", Nature Photonics 4, 291 (2010)
- A. Hugi, G. Villares, S. Blaser, H. C. Liu & J. Faist, "[Mid-infrared frequency comb based on a quantum cascade laser](#)", Nature 492, 229-233 (2012)

Broad Band LASER Illuminator

- Main features
 - High radiance
 - Broad spectrum
 - Cryogen Free, Air or Water cooling
 - Electrical Laser source, can be triggered for synchronous measurements
 - Single mode diffraction limited, can be imaged into any optical system without power loss
 - Can be exchanged against a narrow line laser providing even more radiance.

Broad Band LASER Illuminator

- Plug and play fully room temperature system
- Available in various wavelength regions using the same hardware.
 - 6 to 7 μm
 - 7 to 8.5 μm
 - 8 to 10 μm
 - 10 to 12 μm
- 4 to 20 mm beam diameter
- Long lifetime (>5 years)

Broad Band LASER Illuminator

- The next graph shows the emission spectrum of the Broad Band Laser Illuminator (BBLI)
- The operation conditions
 - $T = -30$
 - Optical power ≈ 10 mW (low repetition rate)
- The power can be increased to 100 mW at high rep rate.
- The device is free running without any filter or stabilisation

Broad Band LASER Illuminator

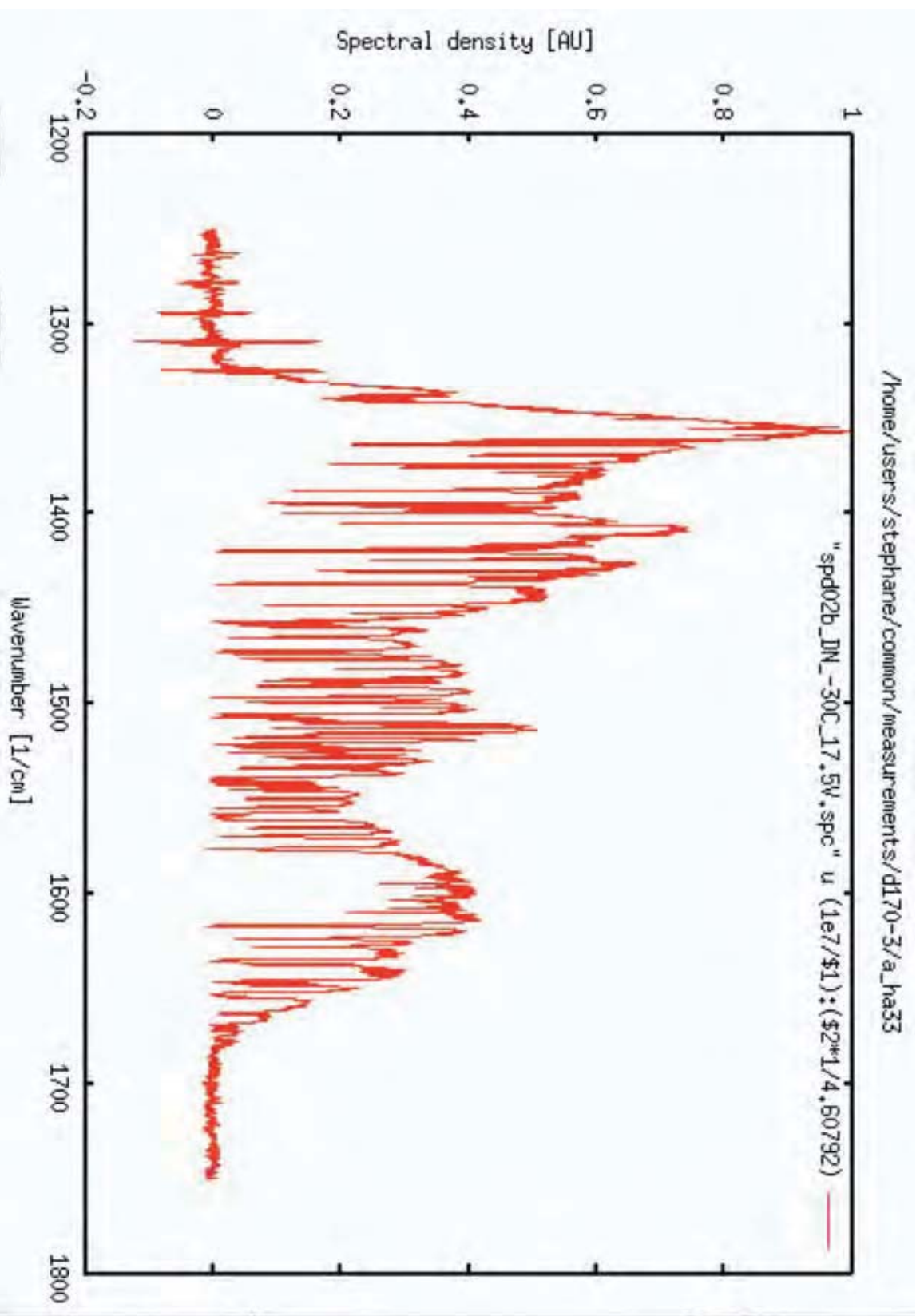

Broad Band LASER Illuminator

- The origin of the dips in the spectrum is related to absorptions in the laboratory atmosphere
- The next slide presents the same laser at various operation conditions together with a spectrum of the lab atmosphere measured using the same FTIR (Bruker Vertex 70 at 0.2 cm^{-1}) and the internal glow bar.
- The various conditions are:
 - Blue curve: 200 ns Pulses
 - Red curve: 100 ns Pulses
 - Green curve: 50 ns Pulses
 - Purple curve: 22 ns Pulses

Broad Band LASER Illuminator

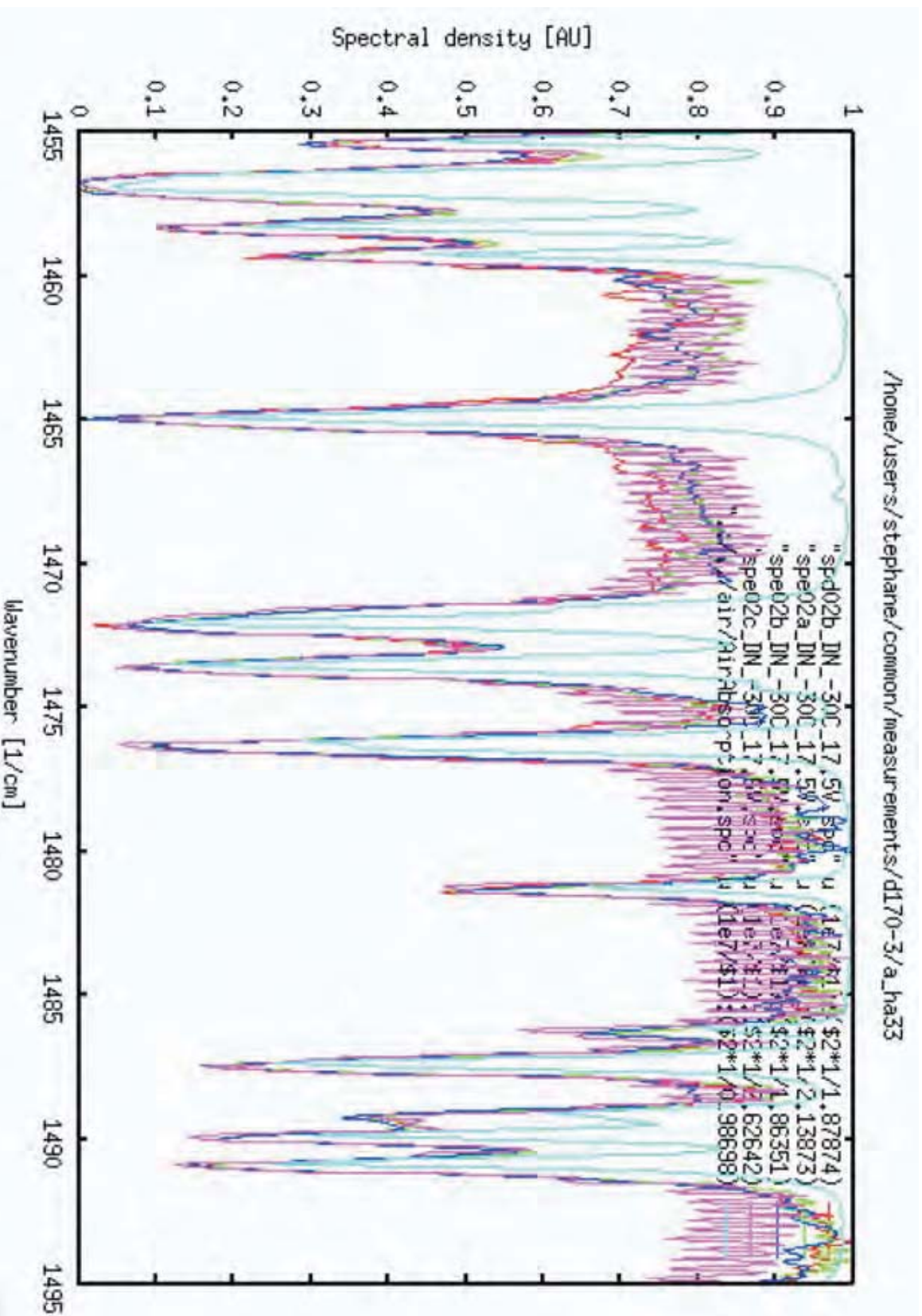

Broad Band LASER Illuminator

- The blue spectrum is clearly the smoothest and the purple, the most structured. This is due to the fact that the laser tunes during the pulse smoothing out the comb of modes produced by the Fabry-Pérot cavity.
- In a QCL, there is no carrier effects on the index of refraction.
- During a pulse the laser heats inducing a change of its index of refraction.
- The free running laser exhibits a comb of modes spaced according to the index of refraction of the cavity.
- When the index changes during the pulse this comb sweeps and averages out within the pulse duration (200 ns)

Conclusion

- The Broad Band LASER Illuminator (BBLI) is a powerful high radiance diffraction limited laser source.
- The BBLI is capable of replacing a Glow Bar for applications where high optical power is needed.
- The BBLI is capable of providing continuous high power smooth spectrum over a limited region.
- The BBLI is available centered at 6.5 μm , 7 μm , 9 μm and 11 μm . It allows to reduce the demand on the detector side.
- The BBLI does not need any cryogenic cooling.

The Source for Unipolar Quantum Cascade Lasers for Mid and Far Infrared

Alpes Lasers introduces TO-3 packaging for its product. This option is available for a limited subset of existing pulsed lasers, different from the published pre-tested lasers. Contact us for information.

TO-3 modules are available with AR coated lenses for beam collimation or flat windows.

TO-3 Module

TO3 with beam collimation

Technical data

TEC	Value	Units
I_{max}	3.0	[A]
U_{max}	5.9	[V]
Q_{max}	9.8	[W]
$Z_{NTC}(25^{\circ}C)$	10	[k Ω]

WINDOW	Body
ZnSe window	Al body; withstands 1 kg shear stress Leak tested

LENS	Value	Units
Numerical aperture	0.86	-
Clear aperture	4.0	[mm]
Outer diameter	5.50	[mm]
Divergence	<10	[mRad]
Pointing	<10	[mRad]

Physical Characteristics	
Maximum width	38.9 mm
Small axis width	25.9 mm
Distance between screw holes	30.0 mm
Cap width	20.64 mm
Cap height	18.0 mm
Pin length	12.0 mm

Technical drawing

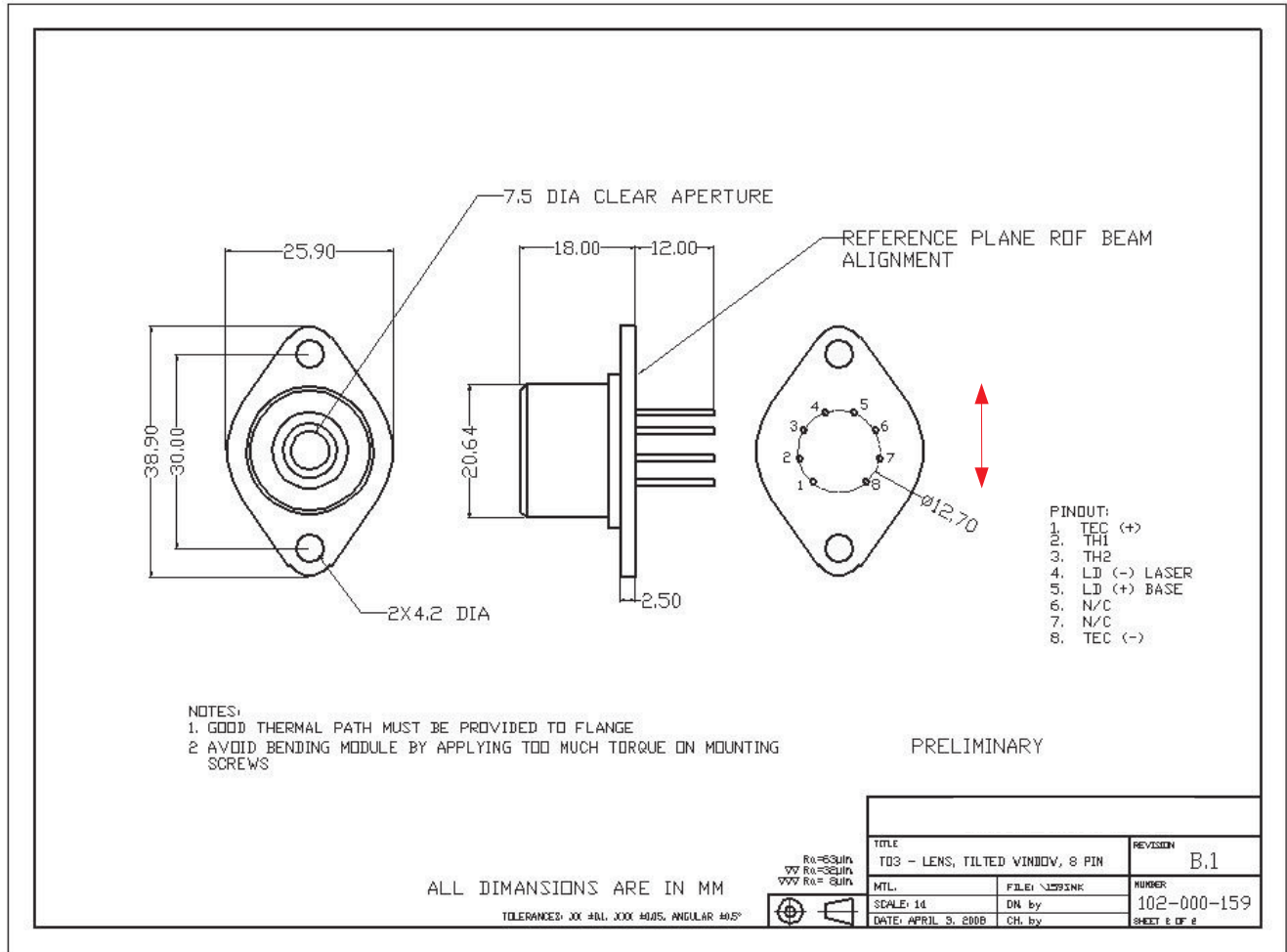

MODULE PIN-OUT	Pin n°
TEC +	1
Thermistor	2
Thermistor	3
Laser bondpad	4
Laser Substrate	5
Not connected	6
Not connected	7
TEC -	8

The polarization (i.e. the electric field) is parallel to the red arrow on the drawing above

The Source for Unipolar Quantum Cascade Lasers for Mid and Far Infrared

Alpes Lasers offers TO-3 packaging for its product. This option is available for a limited subset of existing pulsed or CW lasers, different from the published pre-tested lasers. Contact us for information.

TO-3 modules are available with AR coated lenses for beam collimation or flat windows.

TO3 with divergent beam

TO-3 Module

Technical data

TEC	Value	Units
I_{max}	3.0	[A]
U_{max}	5.9	[V]
Q_{max}	9.8	[W]
$Z_{NTC}(25^{\circ}C)$	10	[k Ω]

WINDOW	Body
ZnSe window	Al body; withstands 1 kg shear stress Leak tested

Window	Value	Units
Clear Aperture	7.5	[mm]
Facet-window distance	1.1	[mm]

Physical Characteristics	
Maximum width	38.9 mm
Small axis width	25.9 mm
Distance between screw holes	30.0 mm
Cap width	20.64 mm
Cap height	12.0 mm
Pin length	12.0 mm

Technical drawing

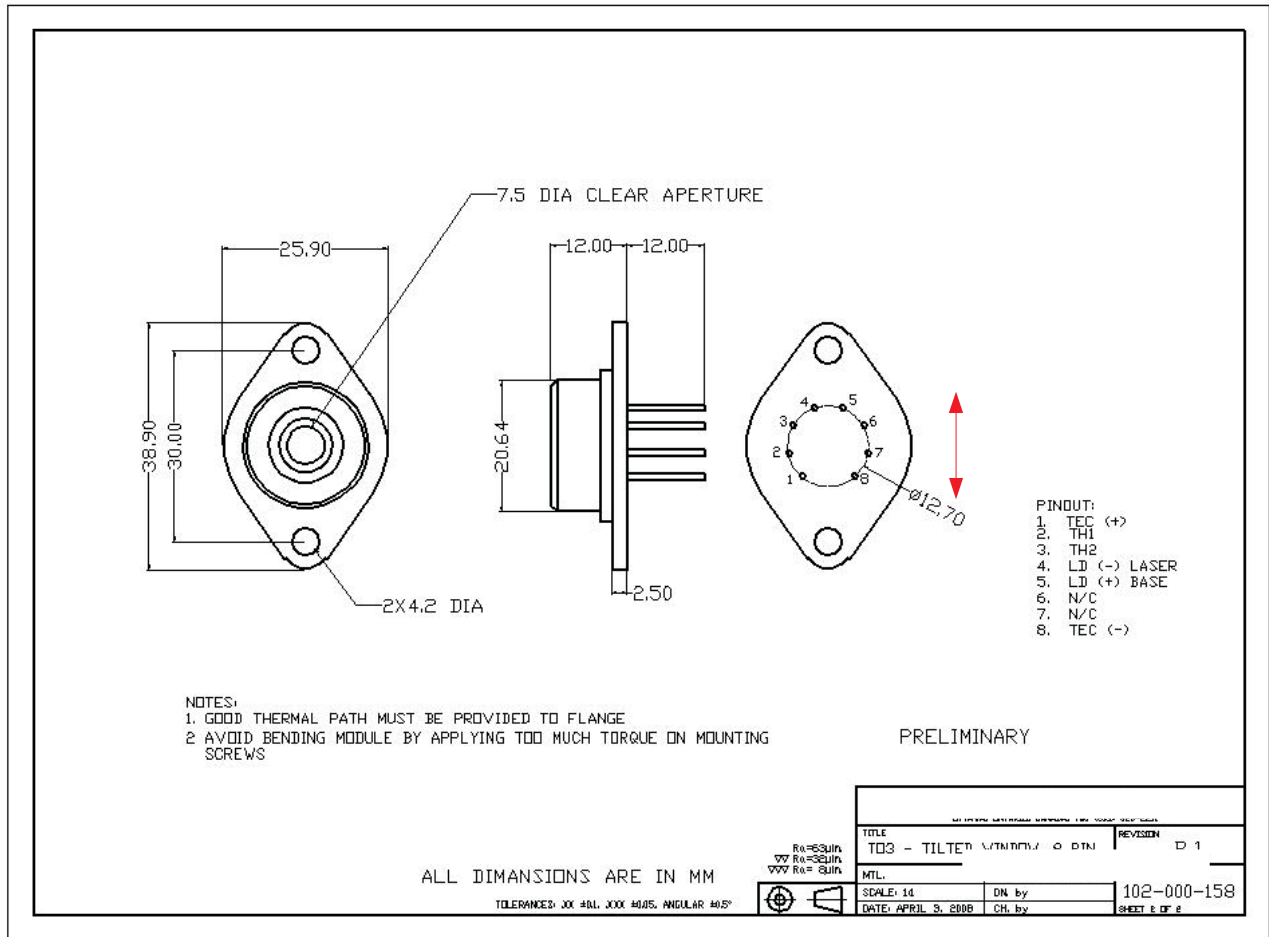

MODULE PIN-OUT	Pin n°
TEC +	1
Thermistor	2
Thermistor	3
Laser bondpad	4
Laser Substrate	5
Not connected	6
Not connected	7
TEC -	8

The polarization (i.e. the electric field) is parallel to the red arrow on the drawing above

Datasheet for HHL-27

Recommendations:

Please read the starter kit user manual, if available, and have a look at the FAQ at <http://www.alpeslasers.ch/alfaq.pdf>

WARNING: Operating the laser with longer pulses, higher repetition rate, higher voltage or higher current than specified in this document may cause damage. It will result in loss of warranty, unless agreed upon with Alpes Lasers!

WARNING: Beware on the polarity of the laser. This laser has to be powered with negative pole on the pin 7 and positive pole on the pin 4.

WARNING: Avoid bending module by applying too much torque on mounting screws. Keep temperature change rates below 10 degrees per minute.

MODULE PIN-OUT	Pin n°
TEC (-)	1
Nonexistent	2
Not connected	3
Positive contact of the laser	4
Temperature sensor	5
Temperature sensor	6
Negative contact of the laser	7
Not connected	8
Not connected	9
TEC (+)	10

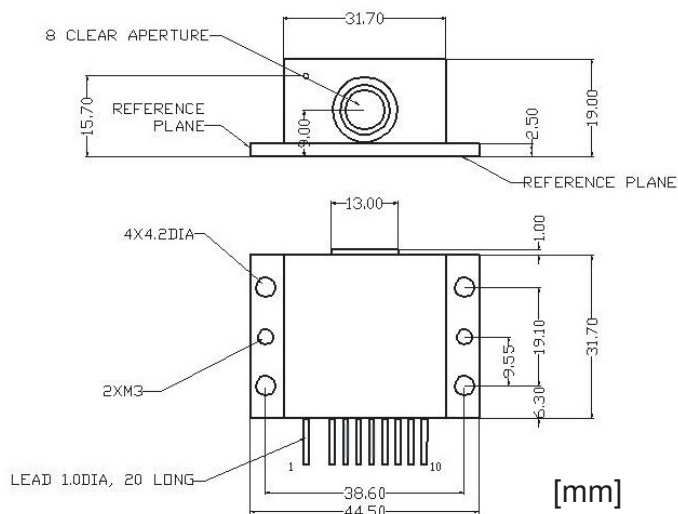

Figure 1: Support mounting for HHL-27 (specifications of the HHL-L module)