

Miniature Infrared Sources & Driver



Visit our web store to purchase or speak with our application specialists.

See our separate catalogs for other sources:

Mid-IR LEDs: 3.3 to 4.3 μm

Quantum Cascade Lasers: spectroscopic grade QCLs

Calibration Grade Blackbodies: NIST traceable



 **Boston**Electronics

91 Boylston Street, Brookline, MA 02445
tel: (617)566-3821 fax: (617)731-0935
www.boselec.com boselec@boselec.com

Thermal Emitter Temperature and Color Correlation

Centigrade	Fahrenheit	Color (Apparent)
400	752	Red heat visible in the dark
474	885	Red heat visible in twilight
525	977	Red heat visible in daylight
581	1078	Red heat visible in sunlight
700	1292	Dark red
800	1472	Dull cherry red
900	1652	Cherry red
1000	1832	Bright cherry red
1100	2012	Orange red
1200	2192	Orange yellow
1300	2372	Yellow white
1400	2552	White welding heat
1500	2732	Bright white
1600	2912	Dazzling white (bluish white)

Boston Electronics offers a range of infrared radiation sources, both modulated and unmodulated. Please ask for details.

“Efficiency” of thermal radiation sources, especially those intended to produce energy in the infrared. Specifically, this relates to electrical resistance heaters, analogs of the old tungsten filaments light bulbs but operated at lower temperatures and producing comparatively little visible light.

- Conservation of energy says that the radiative heat output **P** must equal the electrical energy input. Here we mean “heat” to include visible light, light at all wavelengths, emitted according to the black body laws.
- The device materials are not perfect black body emitters. Emissivity does vary with wavelength and is not well known, but emissivity **ε** around 80% is accepted as typical.
- In addition to radiative heat output, every real-world device will have parasitic heat loads **L** due to CONDUCTION through the device structure and CONVECTION in any atmosphere that surrounds the device. We have no obvious way to get a good estimate of the parasitic conduction and convection losses but note that convection and conduction are understood to be linear processes versus absolute temp **K**, while radiative output is proportional to **K⁴**. Therefore radiative transfer is more important at raised (operating) temperatures and dominates. For want of a better number, 80% is proposed as a placeholder.
- Not all wavelengths that are emitted by the hot source are useful to the project. For example, an NDIR gas concentration measurement at 3.3 microns or at 4.27 microns would find that less than 1% of the total black body energy from a 700C emitter would be useful in the measurement. The same < 1% spectral fraction **S** is true for a 1000C emitter although the total useful power does double with the increase in temperature.
- The energy is radiated into at least 2π steradians and up to 4π steradians. How much of it gets to a place that is useful to the user’s task is a function of the user’s optical set up **O** is difficult to estimate in general but is unlikely to be higher than 20%.

SUMMARY: for the example wavelengths of 3.3 and 4.3 microns with IR thermal source temperatures of 700 C or 1000C, our estimate of how much of the total electrical power **P** would be useful **U** is

$$U = P * \epsilon * L * S * O$$

1000 milliwatts becomes $< 1000 * 0.8 * 0.5 * 0.01 * 0.2 = 0.8$ milliwatts in this example. In terms of “efficiency” for the task, < 0.1% looks hard to beat.

As a comment, IR LEDs will have similar spectral efficiency, less parasitic heat to manage, and superior optical beam forming qualities as well as being electronically modulable at higher frequencies.



Boston Electronics offers a large variety of infrared light sources. Choosing the right one among many can be a chore. This sheet is intended to help you make your choice quicker and easier.

Calibration Grade	See our Calibration Grade Source catalog for cavity blackbody sources and extended area sources. NIST traceable.	Cavity blackbody sources from 50 to 1200C. Extended area sources from -30C to +500C.
Instrumentation Grade – for Non-Dispersive IR (NDIR) gas concentration measurements typically	See our Quantum Cascade Laser catalog for details of tunable IR lasers for precision spectroscopy from 4 to 15 ⁺ μm.	DFB lasers with linewidths < 0.001 cm ⁻¹ . External cavity lasers with 1 cm ⁻¹ resolution; high power sources > 1W.
	See our Miniature IR Sources catalog for compact thermal sources for <3 to 15 ⁺ μm.	A wide range of choices differentiated by mechanical package format and by power. Simple and low cost.
	See our IR LEDs catalog for low power LEDs for 2 to 7 ⁺ μm.	Turn on and off in nanoseconds but less spectrally bright than thermal sources.
Heaters	We do not offer sources powerful enough to be used as radiant infrared heaters.	Consider using tungsten-halogen lamps, widely available from other vendors.

HawkEye IR Source Selection

- The HawkEye line of IR Sources includes Pulsable and Steady State emitters and optional Parabolic and elliptical reflectors

PULSABLE SOURCES SUMMARY

- High modulation depth / high pulse rate
- High efficiency - low power consumption
- Long life - > 3 years when used as recommended

TYPICAL SPECIFICATIONS:

Products	Power, W	Voltage, V	Resistance, Ohms	Radiating Area, mm	Temperature, °C	Reflector	Source Material	Package
IR-50	0.69	5.9	50	1.7 x 1.7	650	0.5," 1.0" and 2.0 available	thin film	TO-39
IR-70	0.65	5.1	40	2.2-2.2	700		thin film	TO-39

STEADY STATE SOURCES SUMMARY

- Input power range from low of 1.3W to high of 70 W
- Temperature to 1385° C
- Rugged and Reliable with proven long-life performance
- Material: thin film, filament (NiCr, Kanthal), Silicon Nitride, Silicon Carbide

TYPICAL SPECIFICATIONS:

Product	Power, W	Voltage, V	Radiating Area, mm	Temperature, °C	Reflector	Source Material
IR-12K	11	6	3.5 x 3.5	975	1.0", 2.0" available	Kanthal
IR-12	10	5	3.5 x 3.5	900		NiCr
IR-30K	4.2	2.5	1.8 x 1.8	950	0.5:", 1.0", 2.0" available	Kanthal
IR-30	4.2	2.75	1.8 x 1.8	925		NiCr
IR-21/IR-21V	4	5	1.5 x 3.5	800	1.0", 2.0" available	NiCr
IR-22/IR-22V	4	5	1.5 x 3.5	900	not available	NiCr
IR-40 / IR-41	2.5	26	4 x 3.5	500	41 – 0.5" Available	thin film
IR-43	1.3	14	1.5 x 1.5	600	0.5" Available	thin film

Product	Power, W	Voltage, V	Radiating Area, mm	Temperature, °C	Reflector	Source Material
IR-Si207	24	12	3 x 4.4	1375	1.0" Available	Silicon Carbide
IR-Si217	37	24	6 x 4.4	1385	1.0" Available	Silicon Carbide
<i>IR-Si253</i> EOL	20	12	2 x 5	1170	0.5", 1.0" Available	<i>Silicon Nitride</i>
IR-Si272	30	6	2.8 x 5	1160	1.0" Available	Silicon Nitride
IR-Si295	40	12	3.5 x 12	1200	2.0" Available	Silicon Nitride
IR-Si311	70	12	4.5 x 17	1025	2.0", 3.0" Available	Silicon Nitride

Steady State (CW) Sources

IR-12 Series Miniature 8 to 11 Watt Infrared Emitter



91 Boylston St, Brookline MA 02446
www.boselec.com irsource@boselec.com,
(617)566-3821

This IR source is a thermal emitter with emissivity ~0.8. It is appropriate for use in lab or field instrumentation due to its long life and stable properties.

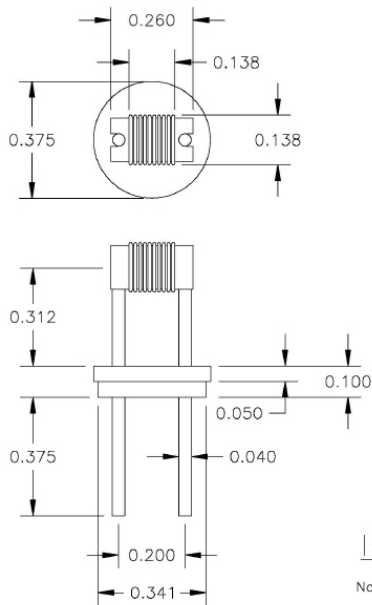

IR-12 Emitter

Note: all dimensions in inches.

The coiled resistance wire filament IR-12 operates at 825°C (1100K) when powered with 4.5 volts @ 1.8 amps (8 watts). The IR-12K takes higher electrical power and runs hotter. Emissivity is ~80% in the IR. The coil is wound on a cylindrical alumina substrate. Generally the IR-12K is recommended for maximum versatility. Operation in a controlled or sealed atmosphere is not required for either device.

The emitter coil is mounted horizontally on an 8.5 mm dia.

base. The emitter support pins also are the power leads and are sealed in glass. Active (coil) area is 3.5 mm dia x 3.5 mm tall.

The Series IR-12 is offered as follows:

Part #	Description	For Long Service Life (Temp @ Volts, Amps)	Recommended Upper Limit
IR-12	Standard unit – power approx 8 watts at 825C	825C @ ~4.5V, 1.8 A Lifetime > 3 years	1025C at ~6V, 2.4 A
IR-12K	Mechanically identical to standard unit but capable of higher temp operation	975C @ ~6.0V, 1.8 A Lifetime > 3 years	1125C at ~7V, 2.2 A

Parabolic and elliptical aluminum reflectors are available to collimate or focus the output of these devices. Boston Electronics can also supply custom designed miniature IR blackbody sources. Please inquire.



HawkEye Technologies, LLC
Your **Source** for **Infrared**

www.hawkeyetechnologies.com

Boston
Electronics

91 Boylston St, Brookline MA 02446
www.boselec.com irsource@boselec.com,
(617)566-3821

IR-12 Steady State Infrared Emitter

ENGINEERING DATA

Temperature vs Voltage

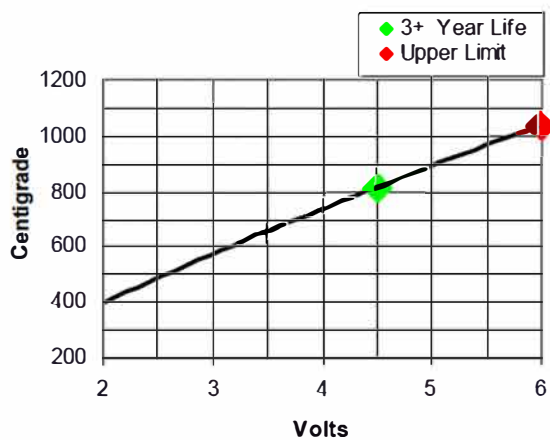

Dimensions

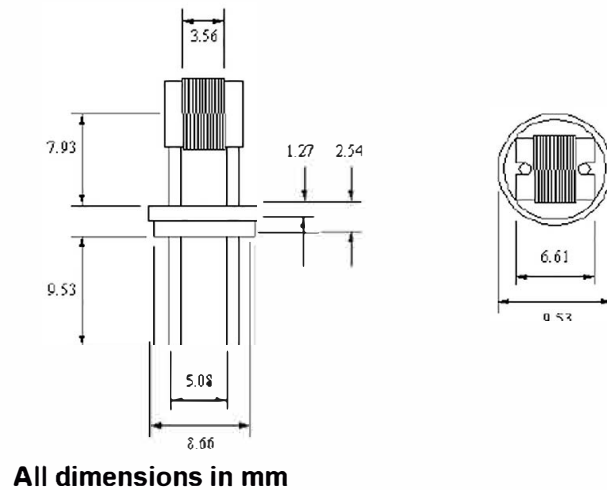

Current vs Voltage

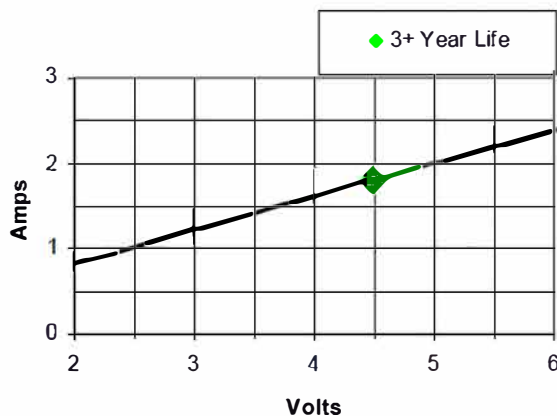

Power vs Voltage

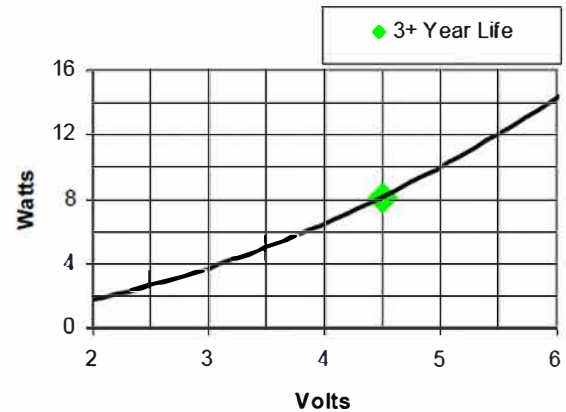

HawkEye Technologies LLC is a custom fabricator of IR sources. We will customize our existing products to your design specifications. We would be pleased to quote a new custom IR source, including engineering, that will meet your requirements.



HawkEye Technologies, LLC
Your **Source** for **Infrared**

www.hawkeyetechnologies.com

Boston
Electronics

91 Boylston St, Brookline MA 02446
www.boselec.com irsource@boselec.com,
(617)566-3821

IR-12K Steady State Infrared Emitter

ENGINEERING DATA

Temperature vs Voltage

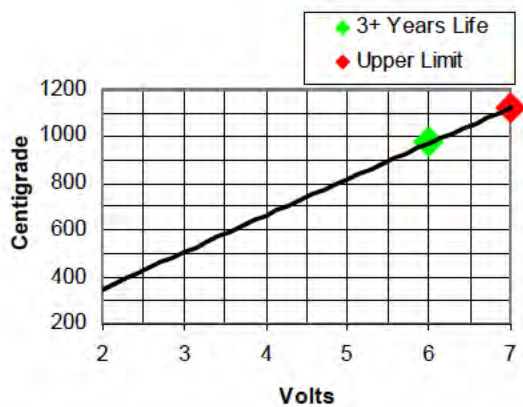

Dimensions

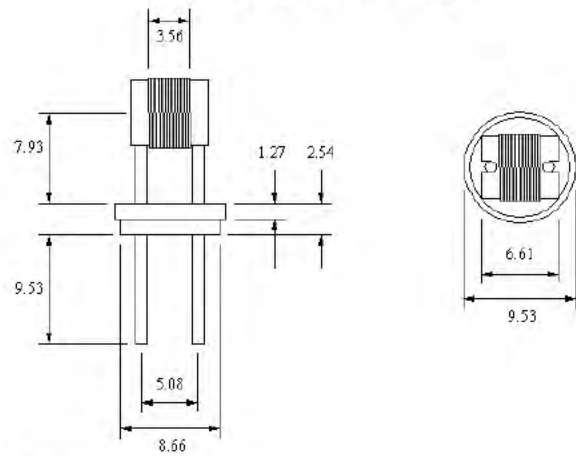

All dimensions in mm

Current vs Voltage

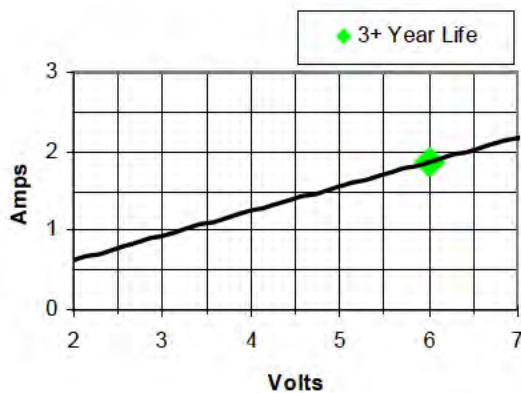

Power vs Voltage

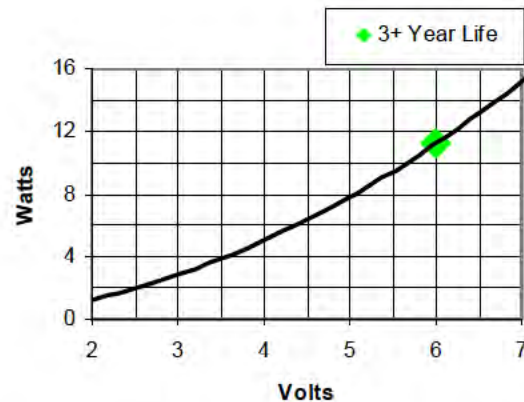

HawkEye Technologies LLC is a custom fabricator of IR sources. We will customize our existing products to your design specifications. We would be pleased to quote a new custom IR source, including engineering, that will meet your requirements.

Parabolic and Elliptical Reflectors For IR-12 and IR-2x series

p/n MC-233 is Elliptical (focused)

p/n MC-234 is Parabolic (collimated)

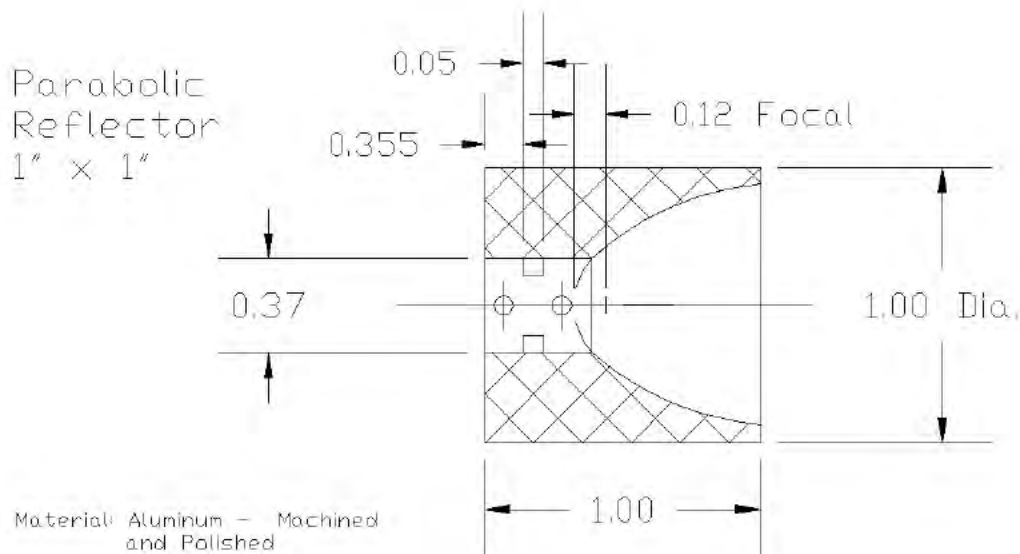
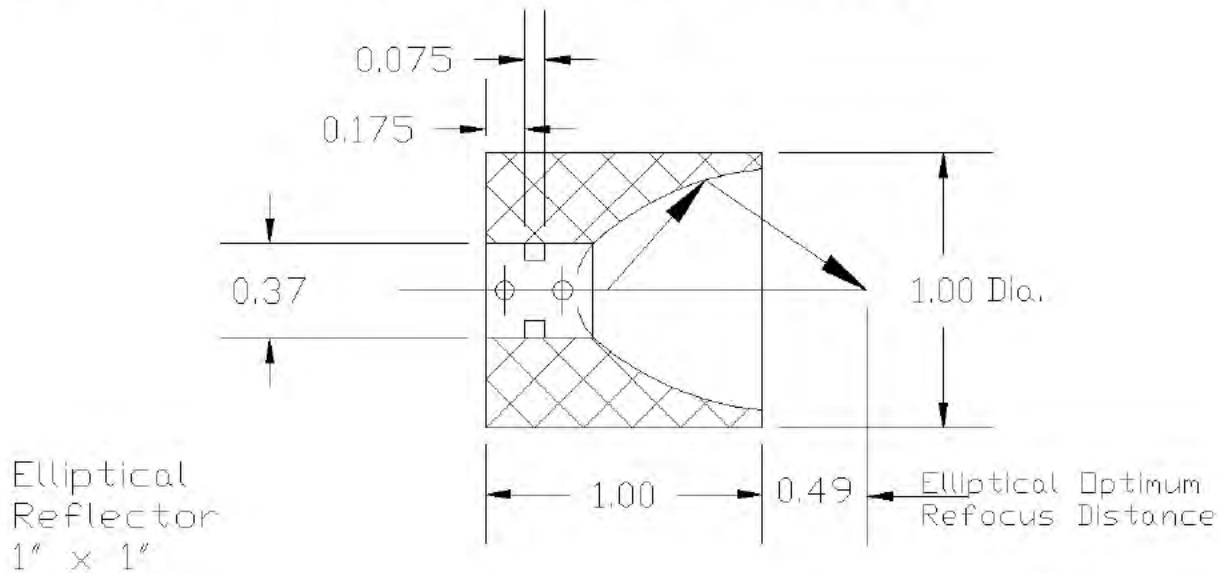

IR-12 with Thermocouple Monitored, Stabilizable IR Source

INFRARED SYSTEM

This Infrared System consists of our standard 800C Series 12 Infrared Light Source, a Type-K Thermocouple and optional digital thermometer.

This unit is intended as a low cost standard unit for general use. These units have been used as checks on Infrared Instruments such as thermometers and cameras. Emissivity value is not guaranteed but fairly constant. Temperature can be monitored quite precisely with this unit and can be maintained constant with feedback to your power source.

When power is applied to the Infrared Light Source the unit heats and the thermometer generates a digital read out of the surface temperature. The thermocouple output can also be used as an input to the [user supplied] power supply system to control the source temperature. Nominal source power requirement is 1.8 amps at 5 volts to maintain 825C [1100K]. The unit can be operated up to 1100K for long [3+ years] duration or at higher temperatures to 1400K for shorter durations. Temperatures from 300K up are easily achievable and operation cooler than 1100K extends lifetime rapidly.

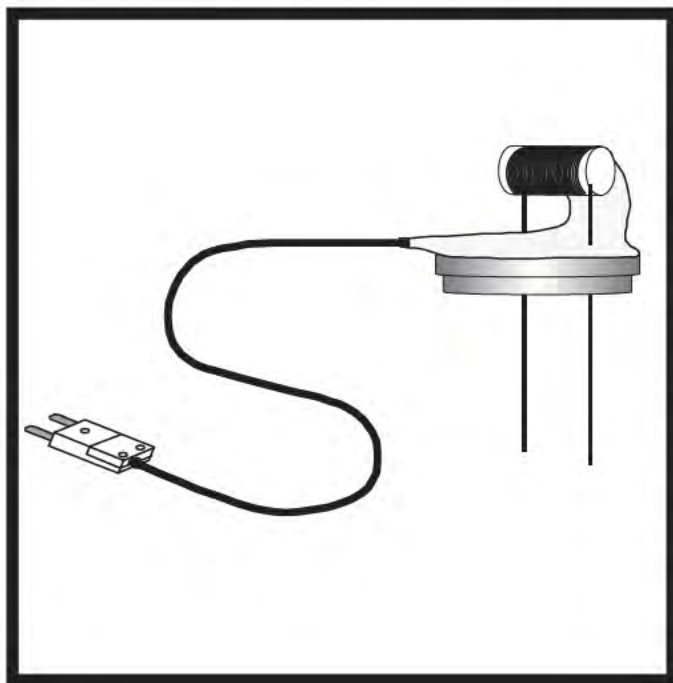

Construction: The Type-K Thermocouple sensor is fabricated using special limit error thermocouple wire. This wire is rated at $\pm 1.1^{\circ}\text{C}$. The sensor is applied directly to the coil of the Infrared Light Source. High temperature, low expansion, material is used to apply the sensor to the source. The thermocouple is terminated with a standard Type-K miniature plug. Other thermocouple types can be supplied on request.

Optional Digital Thermometer: The sensor output probe can be plugged directly into this unit. The meter accepts all type K thermocouple probes with ANSI mini connectors. Meter features: HOLD button to freezes reading, switch for readouts in $^{\circ}\text{F}$ and $^{\circ}\text{C}$. The display has large $\frac{1}{2}$ " digital features. Meter comes with 9 volt battery.

We will customize our existing products to your design specifications. We would be pleased to quote a new custom IR source, including engineering, which will meet your requirements.



IR-Si207 Emitter Datasheet

The IR-Si series emitters are designed to supply higher temperatures and greater output compared to other IR sources. The patented silicon nitride or silicon carbide material ensures a robust design.

Recommended (Maximum) Operating Parameters

Voltage, V	12 (14)
Temperature °C	1260 (1455)
Current, A	1.6 (1.87)
Power, W	19.2 (26.18)

Properties at Recommended Parameters

Life	5,000+ Hours
Emissivity, %	80
Active Area (mm)	3 (L) X 4.4 (W)
Material	Silicon Carbide

IR-Si series emitters can be paired with elliptical or parabolic reflectors for a significantly more efficient collimation of energy. Windows are also available for specific transmitting ranges



Note: All dimensions in mm

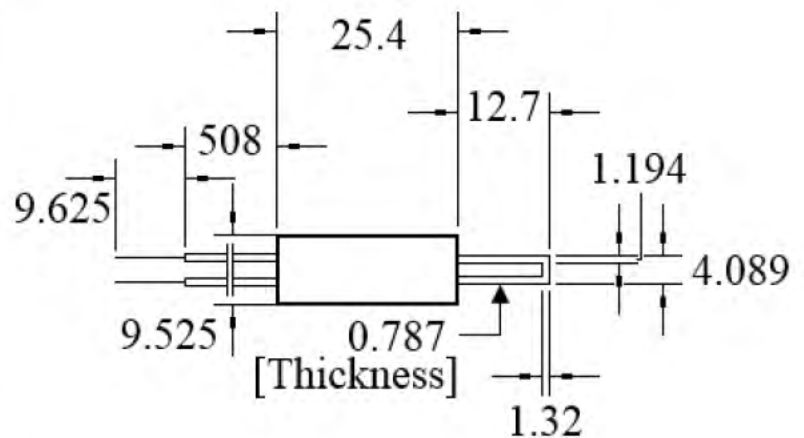

Contact Information:

Boston Electronics
www.boselec.com
shop.boselec.com
boselec@boselec.com
+1.617.566.3821

Published June 4, 2014.

Specifications subject to change without notice.
Please visit our website for the most up to date information.

Sample Data Points

V	10.00	11.00	12.00	13.00	14.00
A	1.47	1.54	1.62	1.73	1.87
W	14.70	16.94	19.44	22.49	26.18
°C	1095	1140	1260	1360	1455

Temperature vs. Voltage

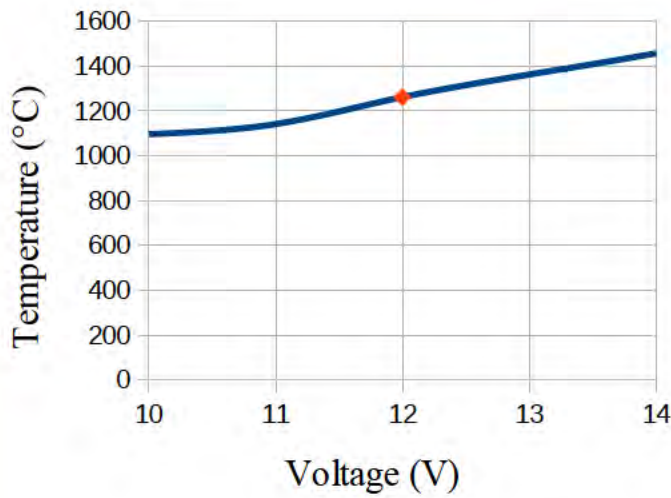

Current vs. Voltage

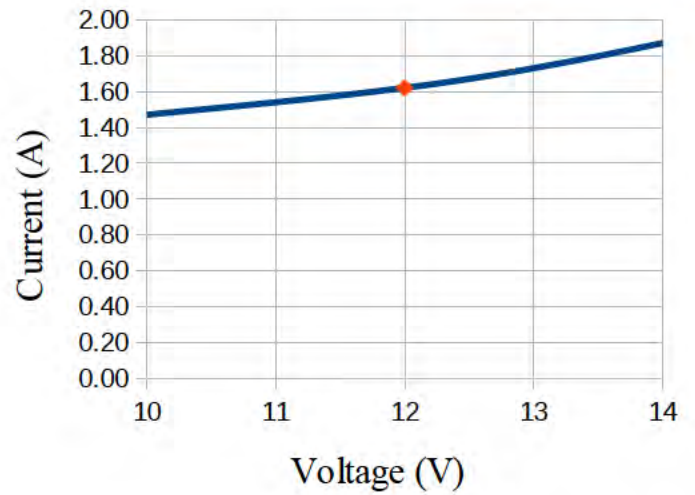

Power vs. Voltage

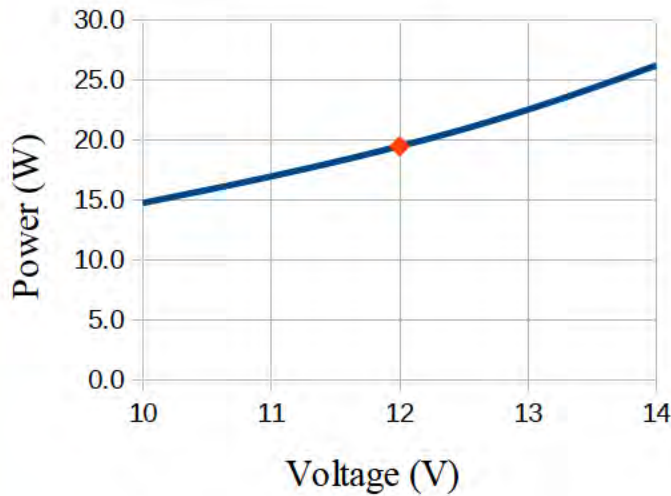

Emission vs. Wavelength

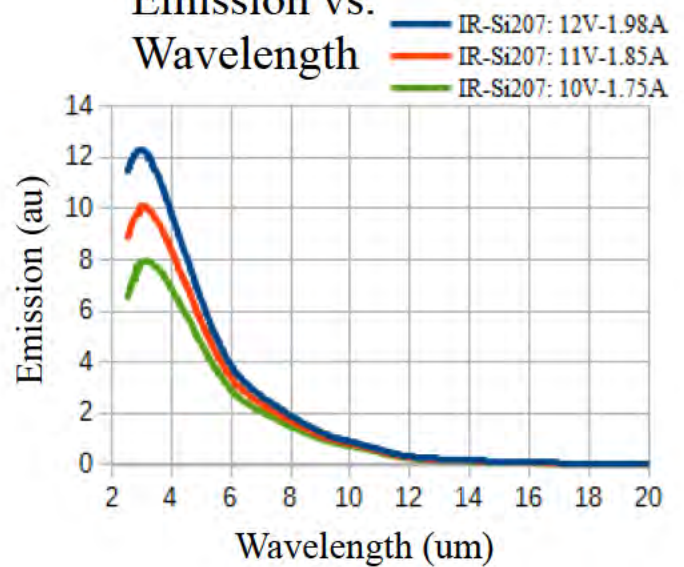

◆: Nearing Maximum Operating Parameters

IR-Si217 Emitter Datasheet

The IR-Si series emitters are designed to supply higher temperatures and greater output compared to other IR sources. The patented silicon nitride or silicon carbide material ensures a robust design.

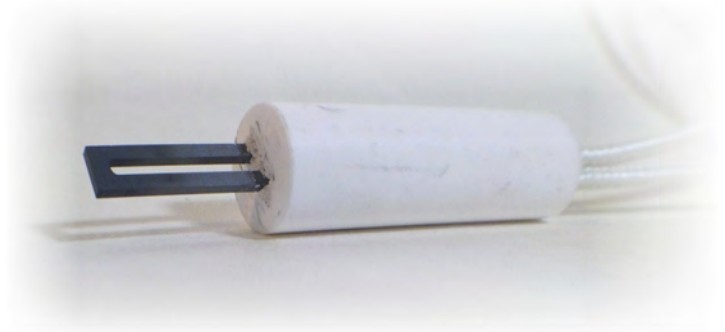

Recommended (Maximum) Operating Parameters

Voltage, V	24	(28)
Temperature °C	1385	(1500)
Current, A	1.5	(1.77)
Power, W	37	(49.56)

Properties at Recommended Parameters

Life	5,000+ Hours
Emissivity, %	80
Active Area (mm)	6 (W) X 4.4 (L)
Material	Silicon Carbide

IR-Si series emitters can be paired with elliptical or parabolic reflectors for a significantly more efficient collimation of energy. Windows are also available for specific transmitting ranges.

Note: All dimensions in mm

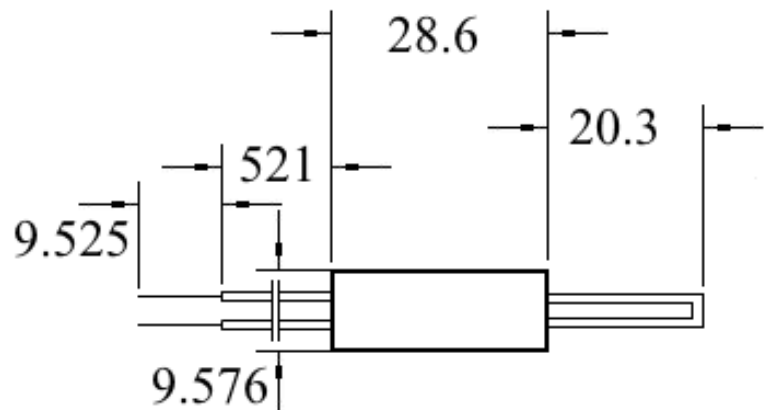

Contact Information:

Boston Electronics
www.boselec.com
shop.boselec.com
boselec@boselec.com
 +1.617.566.3821

Sample Data Points

V	20.00	22.00	24.00	26.00	28.00
A	1.36	1.44	1.55	1.64	1.77
W	27.20	31.68	37.20	42.64	49.56
°C	1250	1300	1375	1425	1500

Temperature vs. Voltage

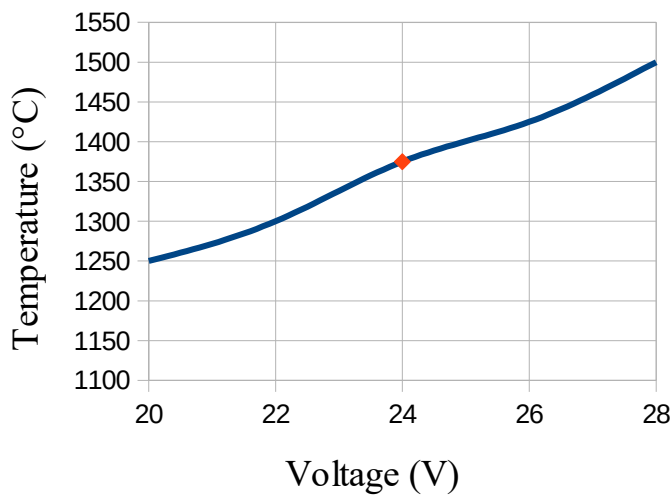

Current vs. Voltage

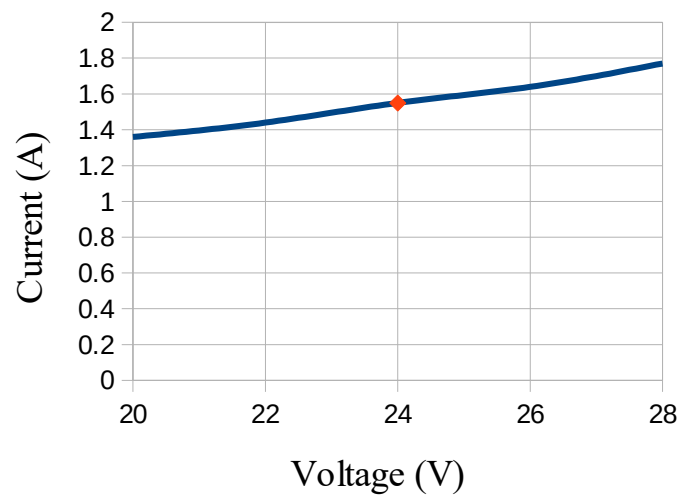

Power vs. Voltage

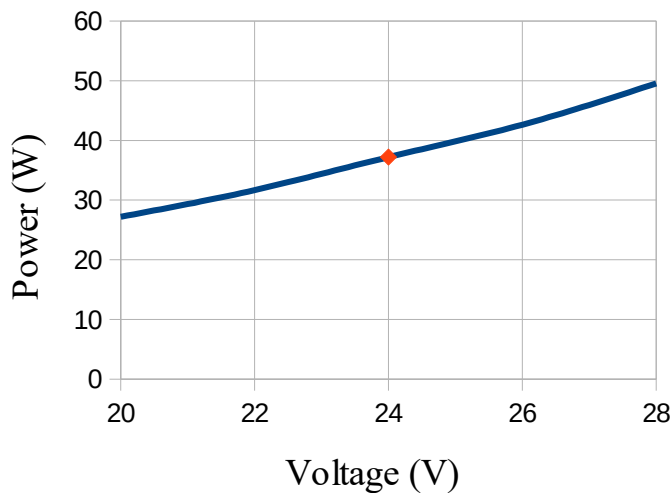

Emission vs. Wavelength

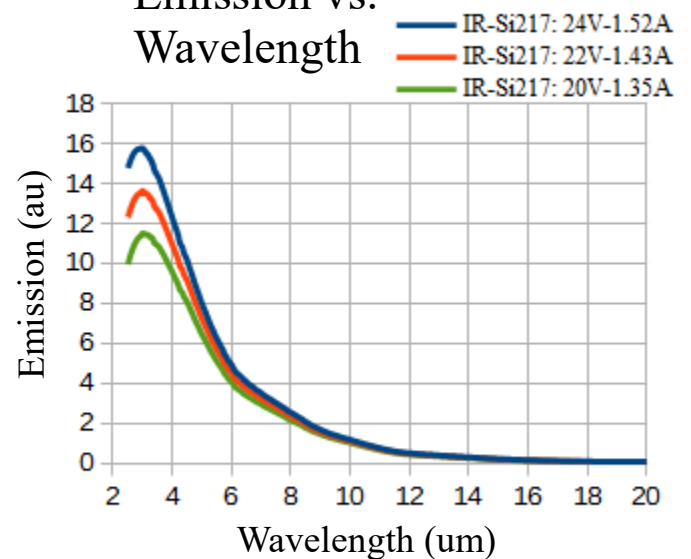

◆: Nearing Maximum Operating Parameters

IR-Si217 Emitter Datasheet

The IR-Si series emitters are designed to supply higher temperatures and greater output compared to other IR sources. The patented silicon nitride or silicon carbide material ensures a robust design.



Recommended (Maximum) Operating Parameters

Voltage, V	24	(28)
Temperature °C	1385	(1500)
Current, A	1.5	(1.77)
Power, W	37	(49.56)

Properties at Recommended Parameters

Life	5,000+ Hours
Emissivity, %	80
Active Area (mm)	6 (W) X 4.4 (L)
Material	Silicon Carbide

IR-Si series emitters can be paired with elliptical or parabolic reflectors for a significantly more efficient collimation of energy. Windows are also available for specific transmitting ranges.

Note: All dimensions in mm

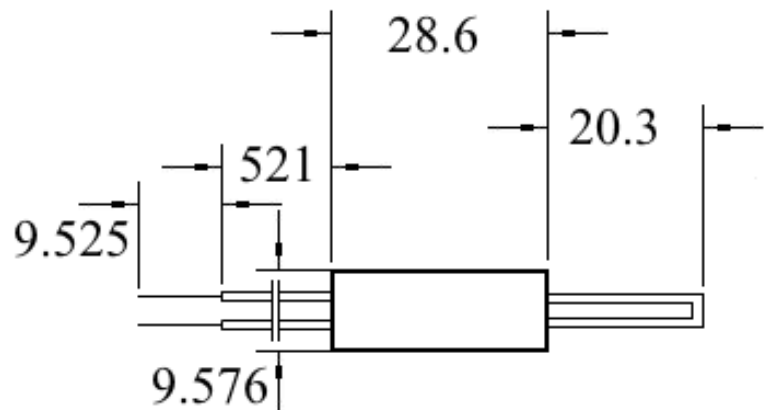

Contact Information:

Boston Electronics
www.boselec.com
shop.boselec.com
boselec@boselec.com
 +1.617.566.3821

Sample Data Points

V	20.00	22.00	24.00	26.00	28.00
A	1.36	1.44	1.55	1.64	1.77
W	27.20	31.68	37.20	42.64	49.56
°C	1250	1300	1375	1425	1500

Temperature vs. Voltage

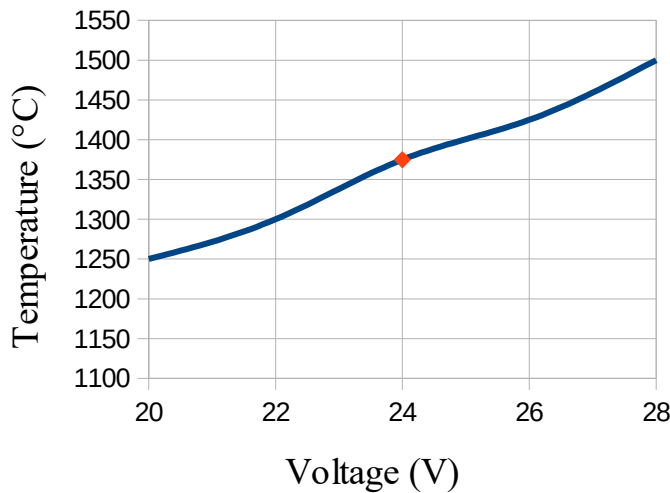

Current vs. Voltage

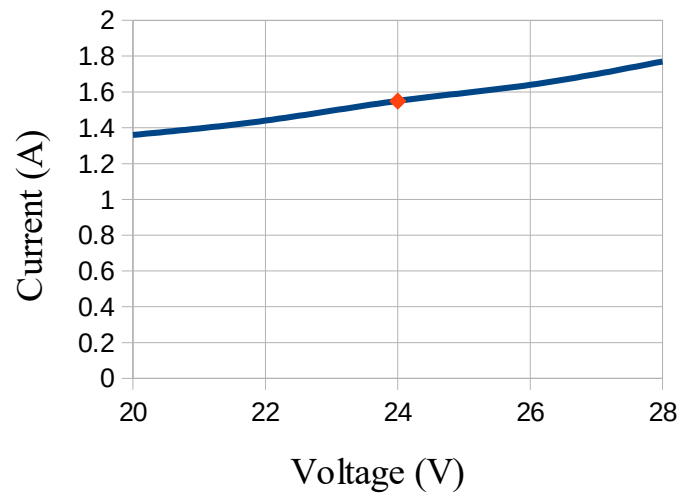

Power vs. Voltage

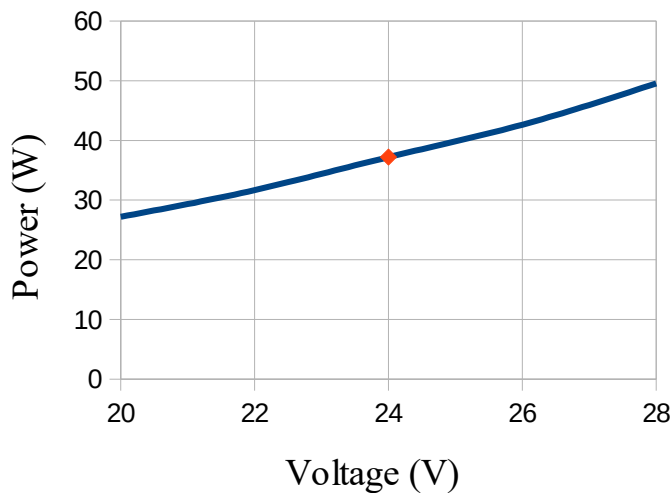

Emission vs. Wavelength

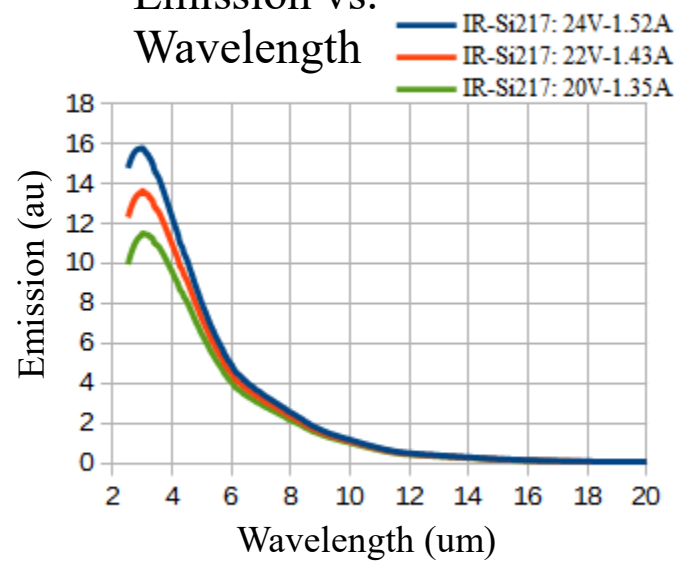

◆: Nearing Maximum Operating Parameters

IR-Si272 Emitter Datasheet

The IR-Si series emitters are designed to supply higher temperatures and greater output compared to other IR sources. The patented silicon nitride or silicon carbide material ensures a robust design.

Recommended Operating Parameters

Voltage, V	6
Temperature °C	1160
Current, A	5.0
Power, W	30.0

Properties at Recommended Parameters

Life	5000+ Hours
Emissivity, %	80
Active Area (mm)	2.8(D) X 5(L)
Material	Silicon Nitride

IR-Si series emitters can be paired with elliptical or parabolic reflectors for a significantly more efficient collimation of energy. Windows are also available for specific transmitting ranges.

Contact Information:

181 Research Drive, #8
Milford, CT 06460, USA
Phone: +1-203-878-6892
Fax: +1-203-878-7462
Email: info@hawkeyetechnologies.com
Website: www.hawkeyetechnologies.com

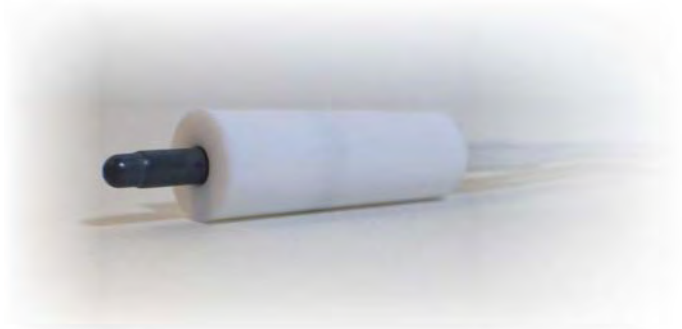

Note: all dimensions in mm

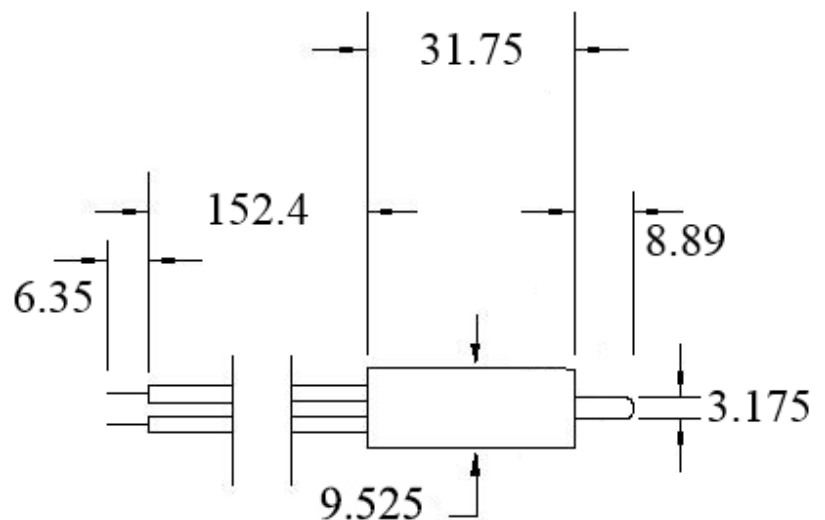

Sample Data Points

V	4.00	5.00	6.00
A	5.00	5.36	5.73
W	20.00	26.80	34.38
°C	920	1035	1245

Temperature vs. Voltage

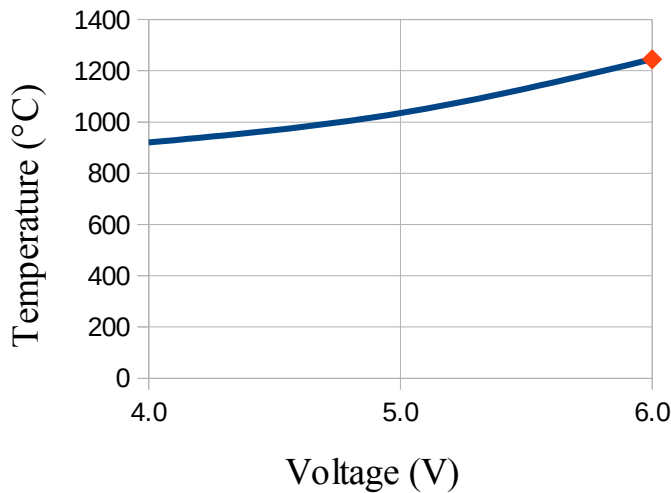

Current vs. Voltage

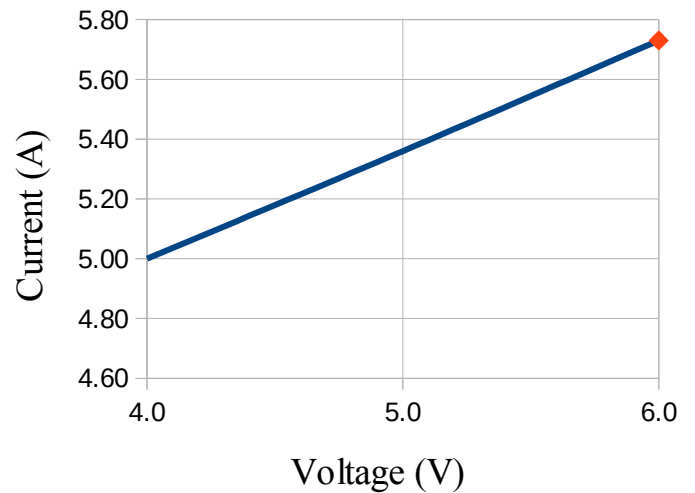

Power vs. Voltage

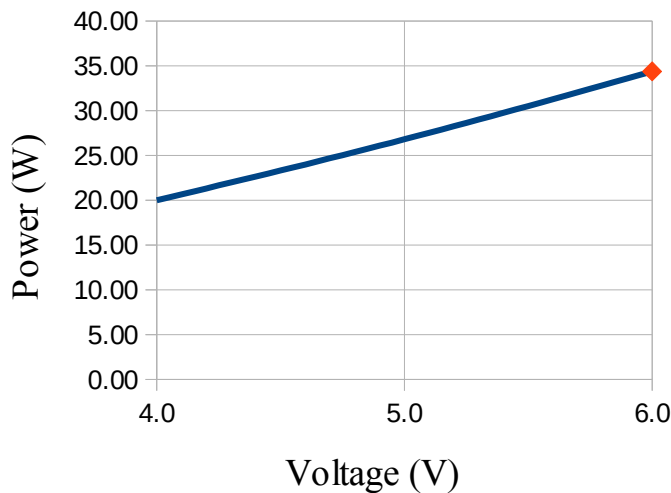

Emission vs. Wavelength

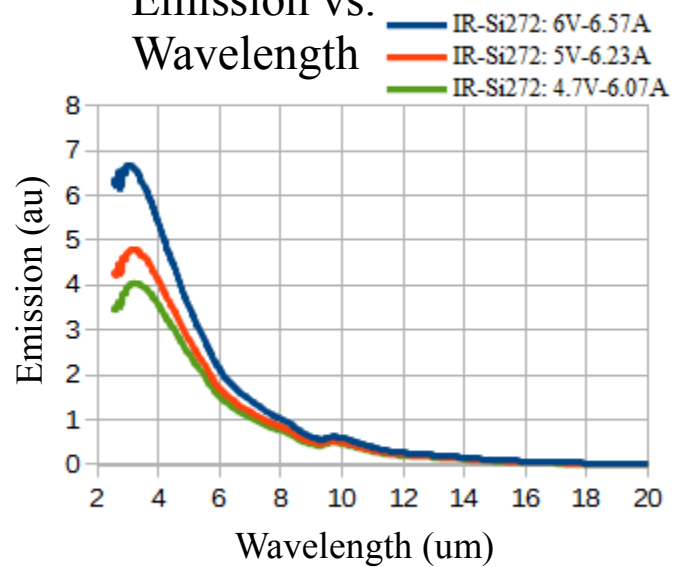

◆: Nearing Maximum Operating Parameters

IR-Si295 Emitter Datasheet

The IR-Si series emitters are designed to supply higher temperatures and greater output compared to other IR sources. The patented silicon nitride or silicon carbide material ensures a robust design.

Recommended (Maximum) Operating Parameters

Voltage, V	12 (14)
Temperature °C	1250 (1340)
Current, A	4.7 (5.1)
Power, W	56.4 (71.4)

Properties at Recommended Parameters

Life	5000+ Hours
Emissivity, %	80
Active Area (mm)	3.5(D) X 12(L)
Material	Silicon Nitride

IR-Si series emitters can be paired with elliptical or parabolic reflectors for a significantly more efficient collimation of energy. Windows are also available for specific transmitting ranges.

Contact Information:

181 Research Drive, #8
Milford, CT 06460, USA
Phone: +1-203-878-6892
Fax: +1-203-878-7462
Email: info@hawkeyetechnologies.com
Website: www.hawkeyetechnologies.com

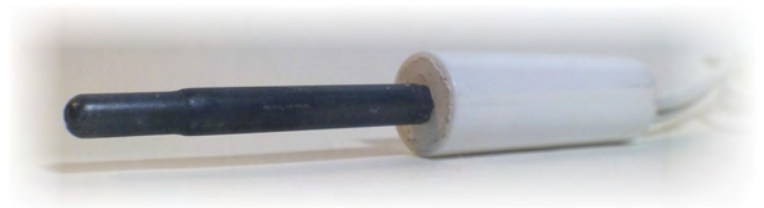

Note: all dimensions in mm

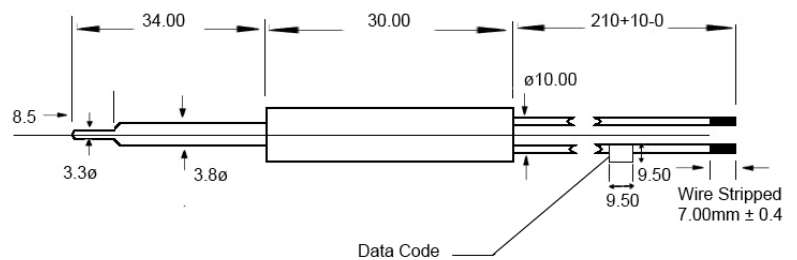

Note: All tolerance $\pm 1.00\text{mm}$ unless otherwise stated

Sample Data Points

V	10	11	12	13	14
A	4.33	4.48	4.71	4.9	5.1
W	43.3	49.28	56.5	63.95	71.4
°C	1105	1170	1255	1295	1340

Temperature vs. Voltage

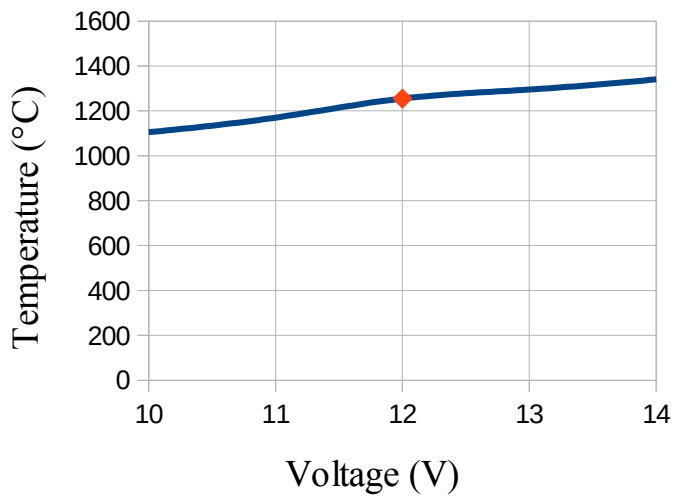

Current vs. Voltage

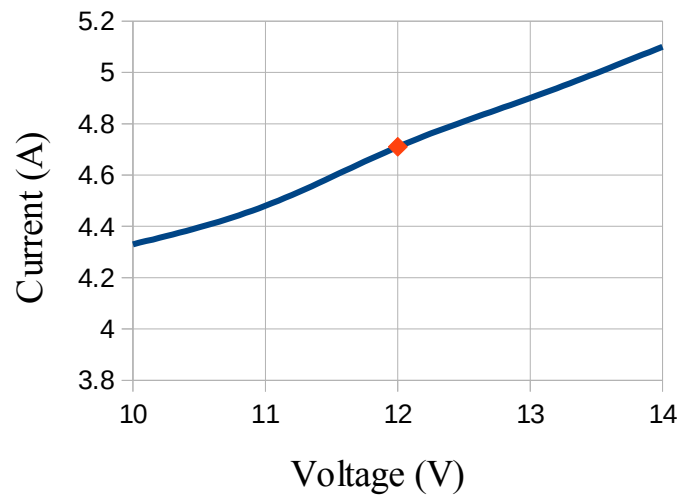

Power vs. Voltage

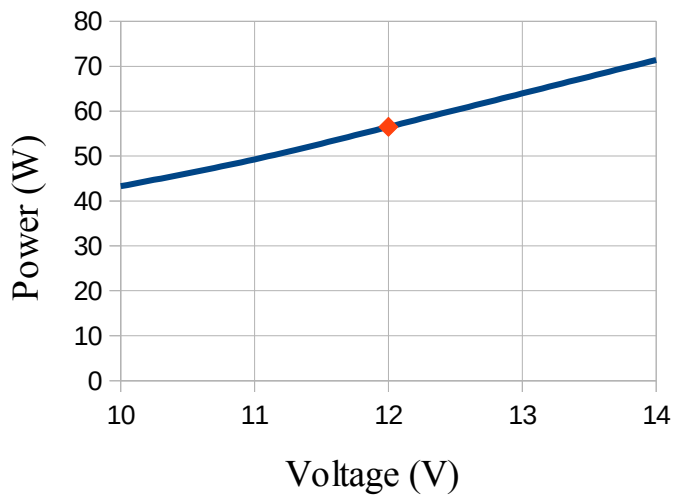

Emission vs. Wavelength

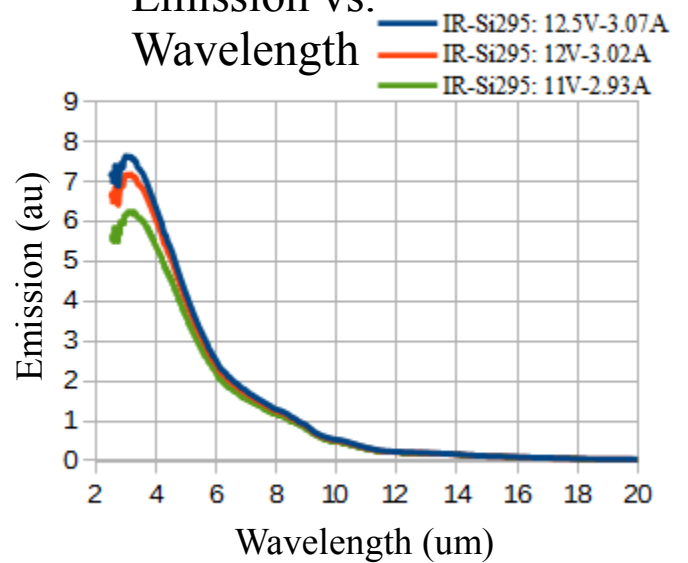

◆: Nearing Maximum Operating Parameters

IR-Si311 Emitter Datasheet

The IR-Si series emitters are designed to supply higher temperatures and greater output compared to other IR sources. The patented silicon nitride or silicon carbide material ensures a robust design.

Recommended (Maximum) Operating Parameters

Voltage, V	12	(14)
Temperature °C	1025	(1090)
Current, A	5.2	(5.5)
Power, W	62.4	(77)

Properties at Recommended Parameters

Life	5000+ Hours
Emissivity, %	80
Active Area (mm)	4.5(D) X 17(L)
Material	Silicon Nitride

IR-Si series emitters can be paired with elliptical or parabolic reflectors for a significantly more efficient collimation of energy. Windows are also available for specific transmitting ranges.

Contact Information:

181 Research Drive, #8
Milford, CT 06460, USA
Phone: +1-203-878-6892
Fax: +1-203-878-7462
Email: info@hawkeyetechnologies.com
Website: www.hawkeyetechnologies.com



Note: all dimensions in mm

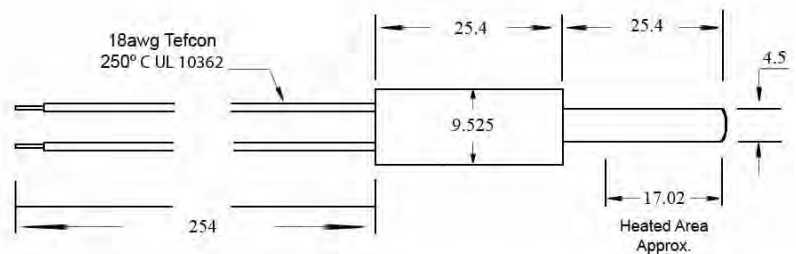

Sample Data Points

V	10	11	12	13	14
A	5.12	5.17	5.20	5.35	5.5
W	51.20	56.87	62.40	69.91	77
°C	990	1000	1025	1055	1090

Temperature vs. Voltage

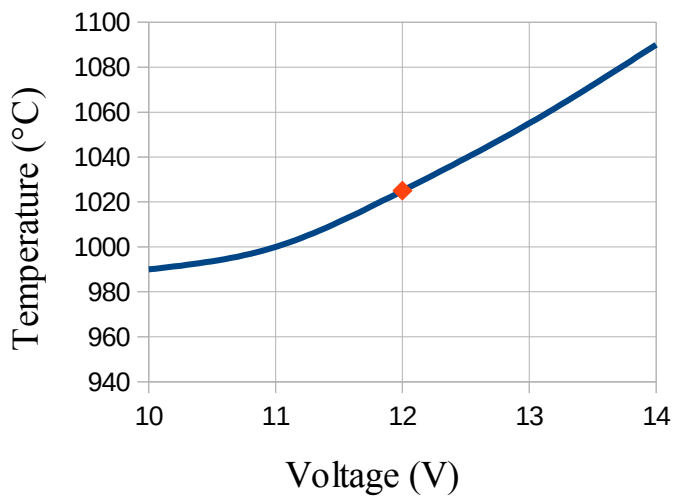

Current vs. Voltage

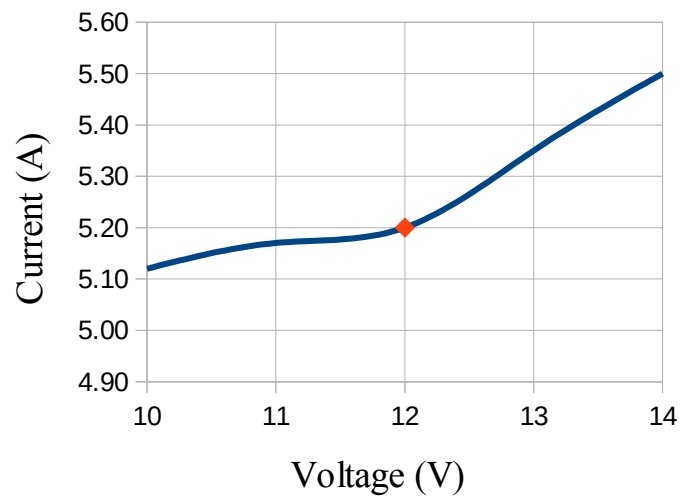

Power vs. Voltage

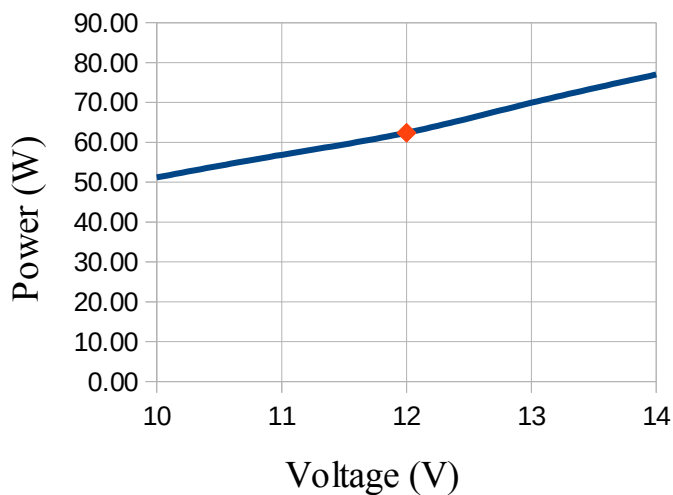

Emission vs. Wavelength

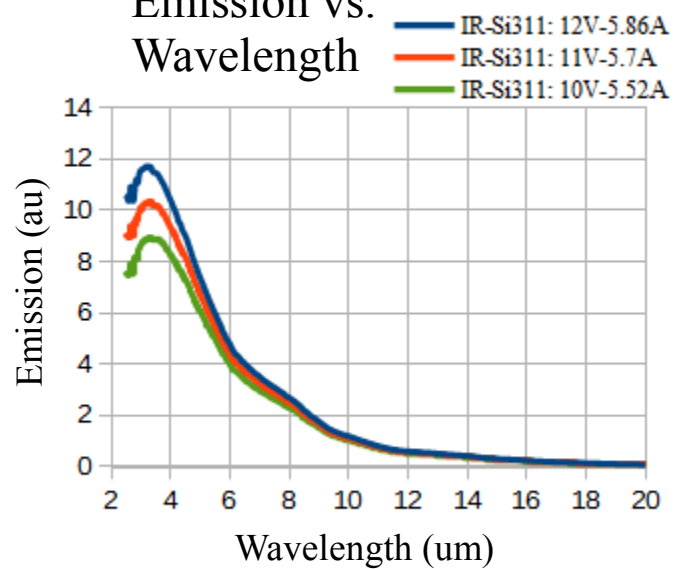

◆: Nearing Maximum Operating Parameters

Infrared Source Series 2x

- Supported, Coil Wound
- Available mounted vertically or horizontally
- Available on large or small base



The coiled filament operates at approximately 800°C when powered with 4 watts. The radiating element is a coil of resistance wire which has a high emissivity in the Infrared spectral region. The coil is supported on a cylindrical substrate of alumina. Due to the reduced mass of this unit it can be pulsed at 1 hertz with a resultant temperature variation that can be detected. The unit does not require operation in a sealed atmosphere.

The Header body is available in two sizes. The larger, IR 21, has 0.200 inch center to center leads. The small, IR 22, has 0.100 inch center to center leads. The support pins are hermetically sealed in glass. The source can be mounted vertically or horizontally.

Recommended Operating Parameters

	IR-21	IR-22
Voltage	5.0 volts (AC or DC)	5.0 volts (AC or DC)
Temp	800° C	900°C
Current	0.8 Amperes	0.8 Amperes
Power	4.0 watts	4.0 watts
Life	30,000 Hours at 5 volts	30,000 Hours at 5 volts
Emissivity	0.80	0.80
Active Area	1.5 mm X 3.5 mm	1.5 mm X 3.5 mm

HawkEye IR-21 Engineering Data Charts

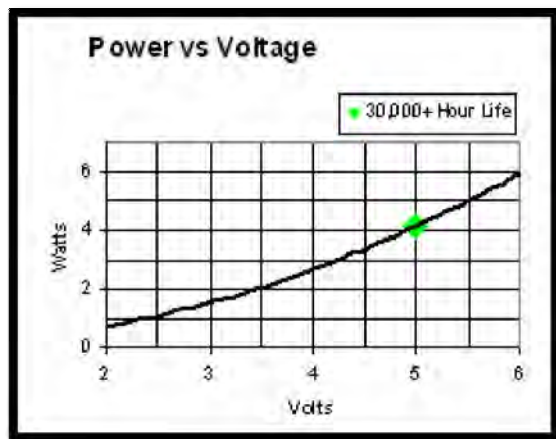
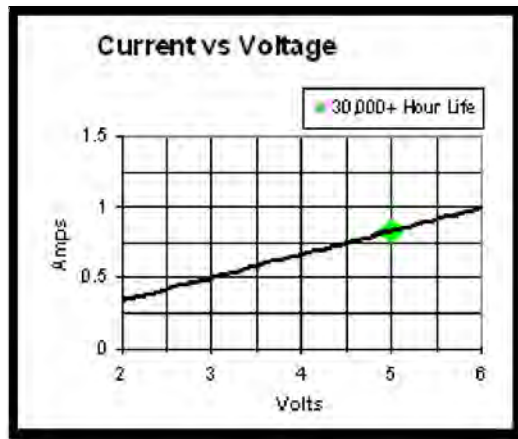
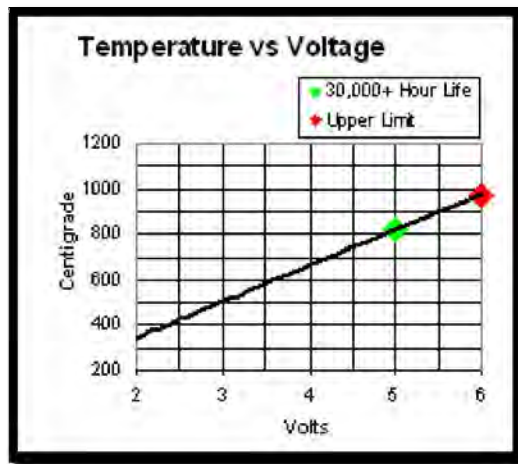

HawkEye IR-22 Engineering Data Charts

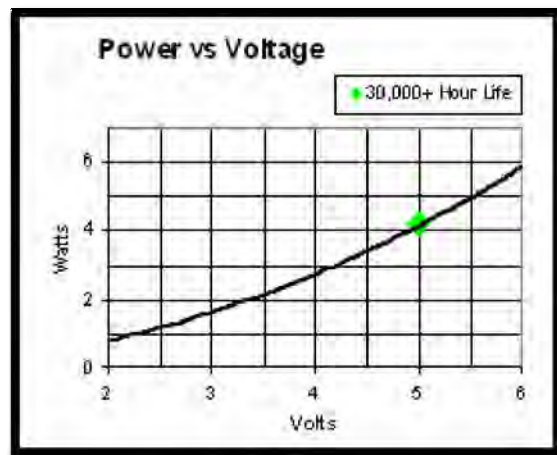
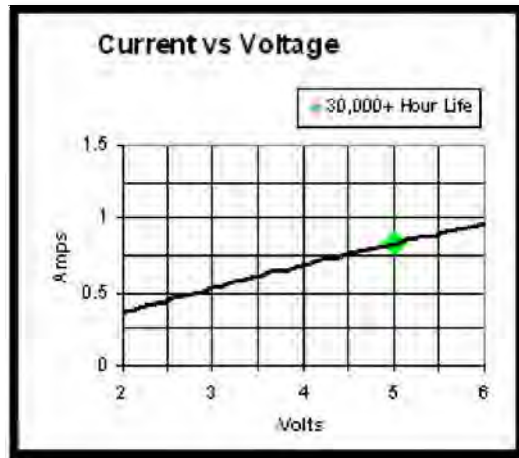
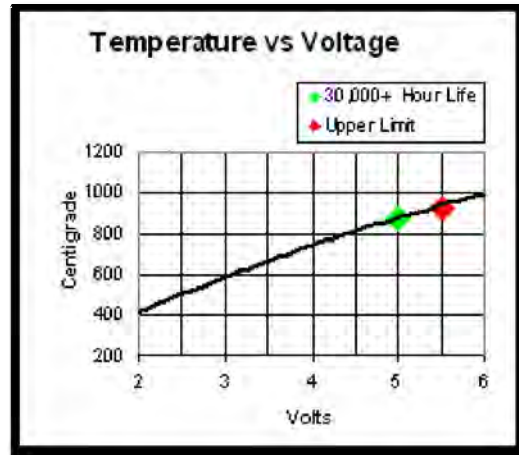

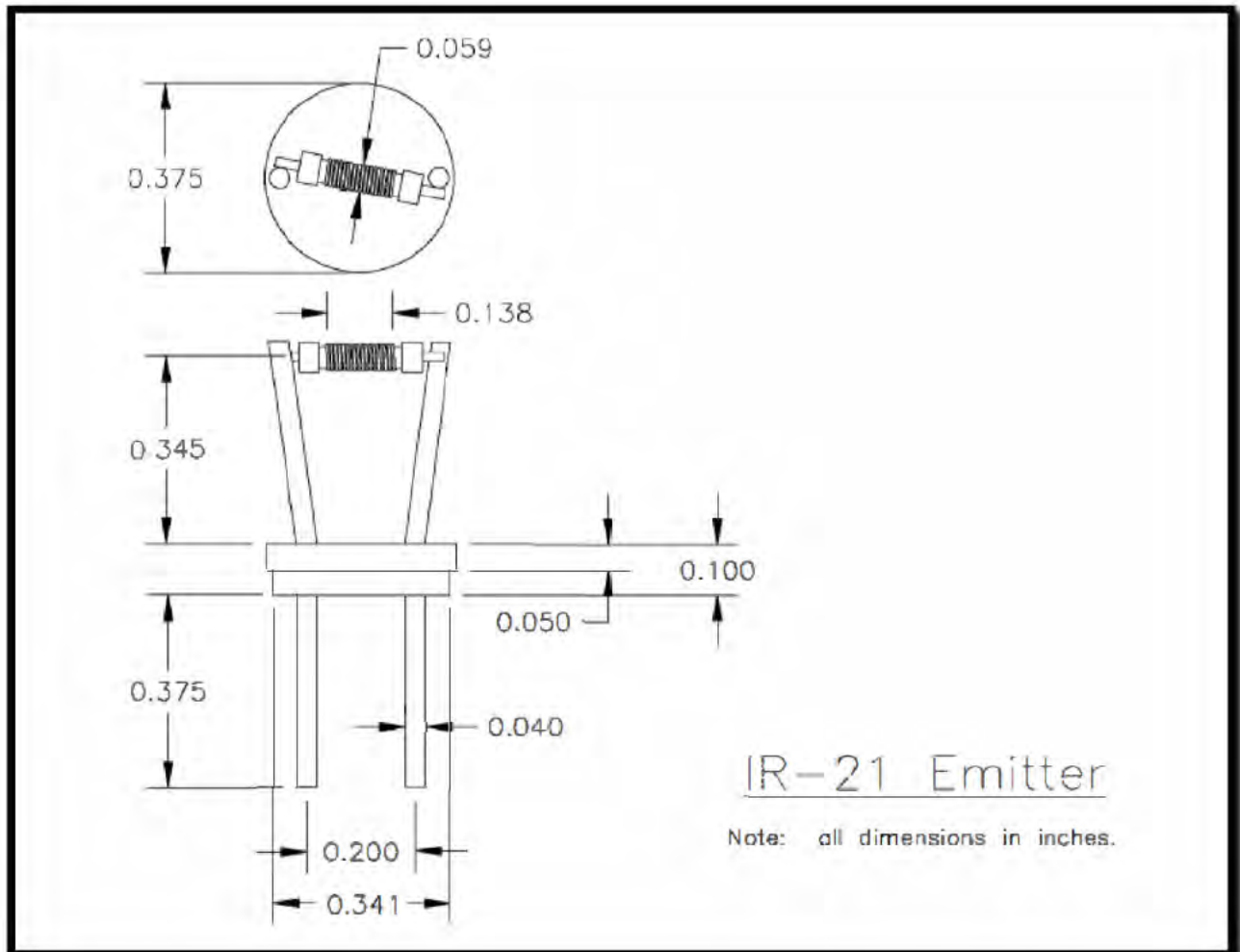

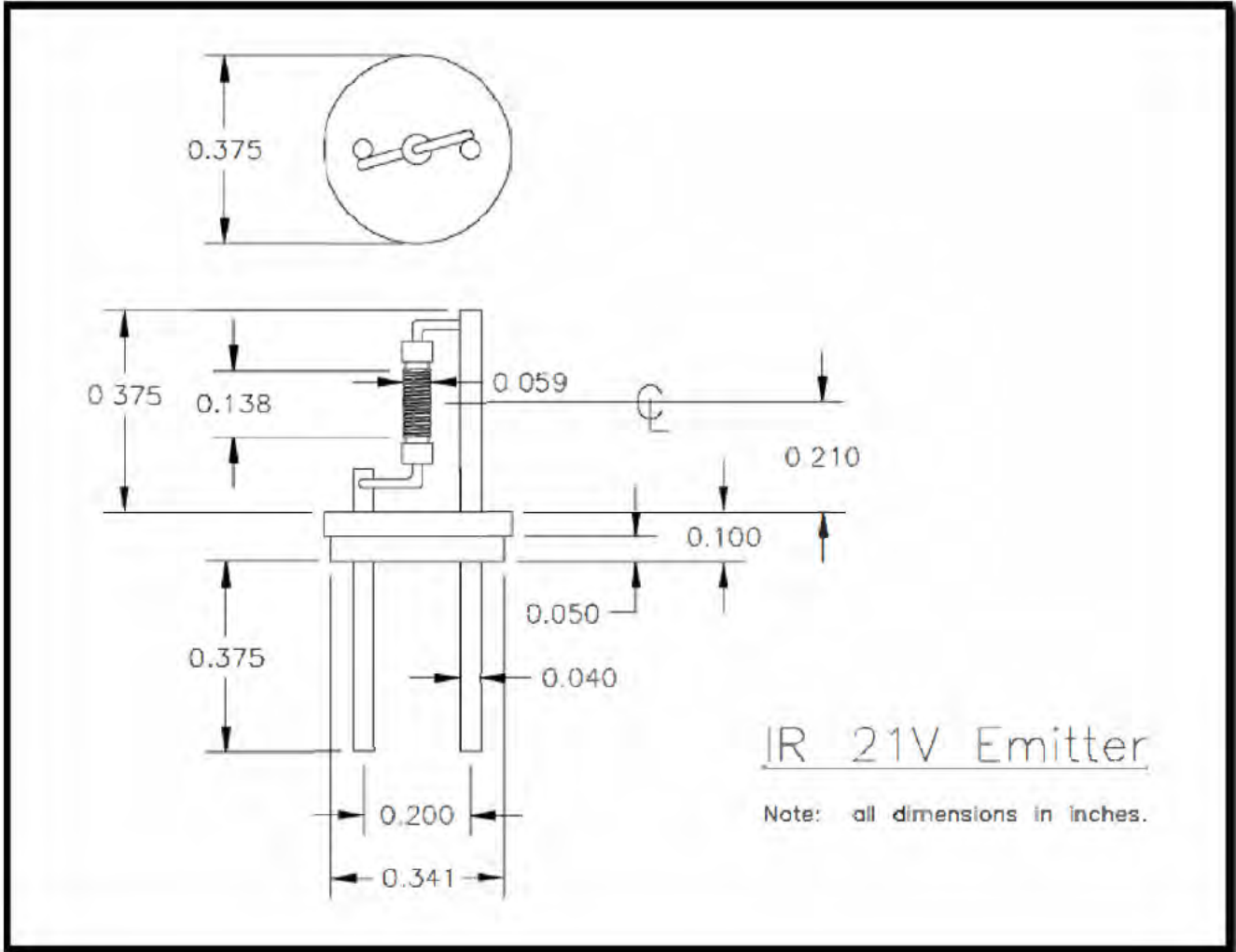

HawkEye IR-2x Lifetime

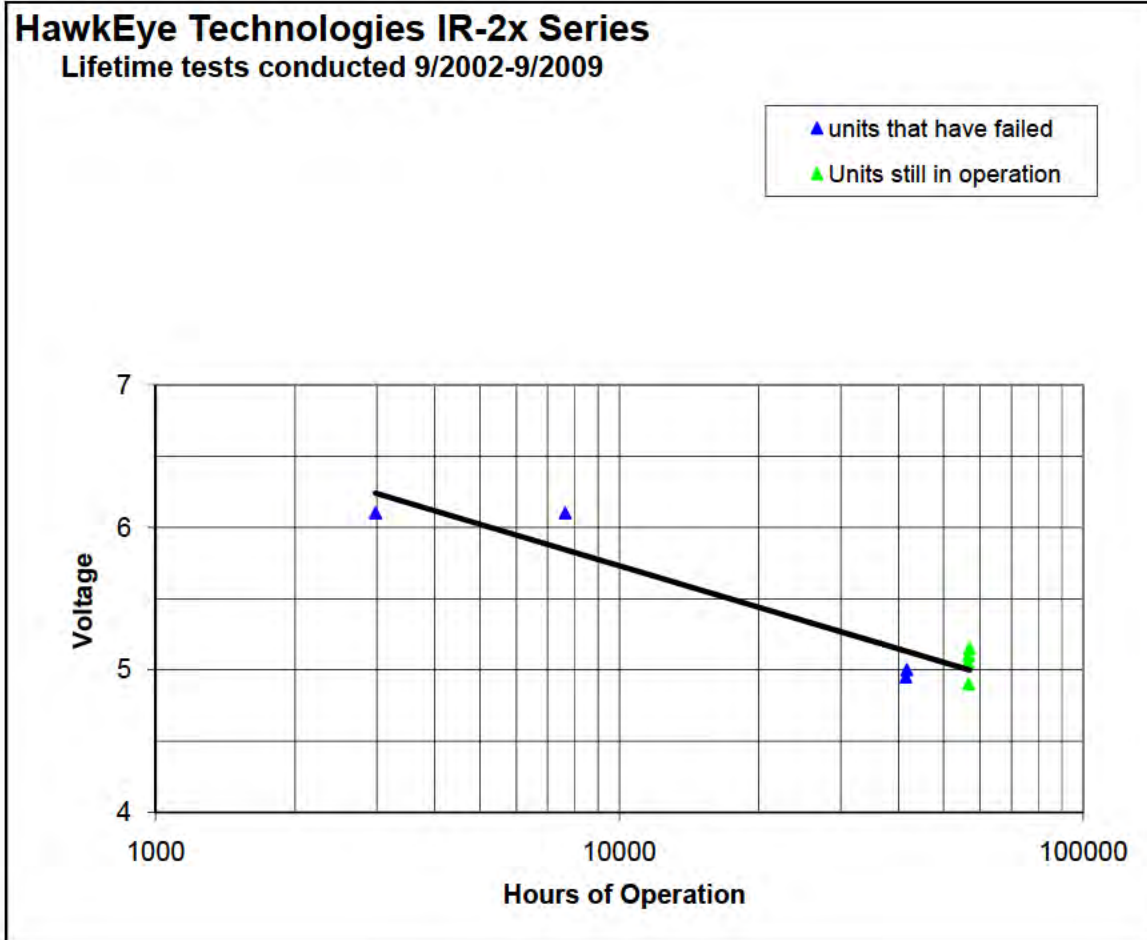

Infrared Source IR-3x

- Supported, Coil Wound
- Operates at 950°C when powered with 4.2 watts
- Pulsable up to 1 Hz
- Available with a parabolic reflector to collimate energy (IR-35)



The IR-3x is a coil-wound, supported IR Source. At steady state, the coiled filament operates at approximately 950 degrees C when powered with 4.2 watts (2.5 volts, 1.7 amps). Expected life at this power level is 25,000 hours. This IR Source can be pulsed up to 1 hertz with a greater power input. For example, when operated at 1 hertz, 50% duty cycle with 3.5 volts and 7.1 watts, the output is a well defined saw tooth with approximately 32% modulation depth. This product is offered as an IR-30 which is mounted on a TO-5 header and also as an IR-35 in a 0.5 inch diameter parabolic reflector (for collimation of energy).

Recommended Operating Parameters

	IR-3x
Voltage	2.5 volts (AC or DC)
Temp	950° C
Current	1.7 Amperes
Power	4.2 watts
Life	25,000 Hours at 2.5 volts
Emissivity	0.70
Active Area	1.8 mm X 1.8 mm

HawkEye IR-3x Engineering Data Charts

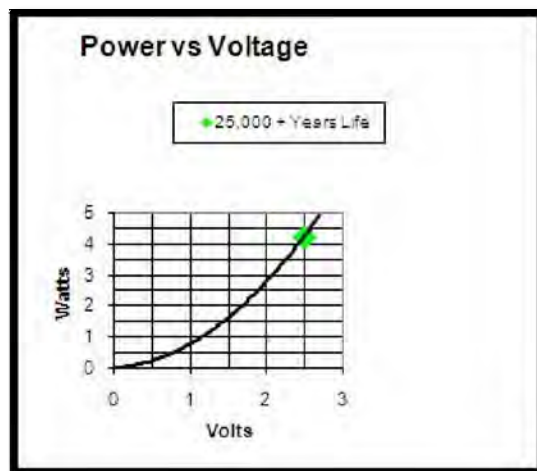
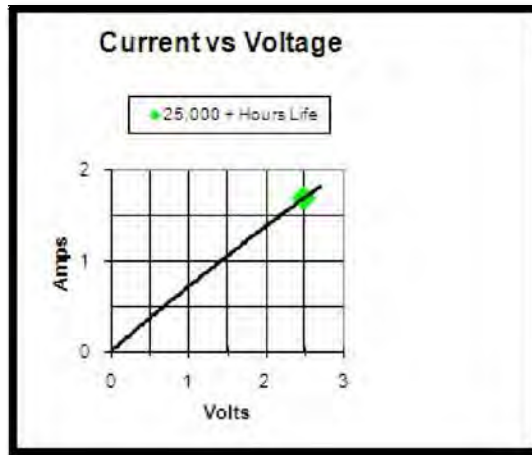
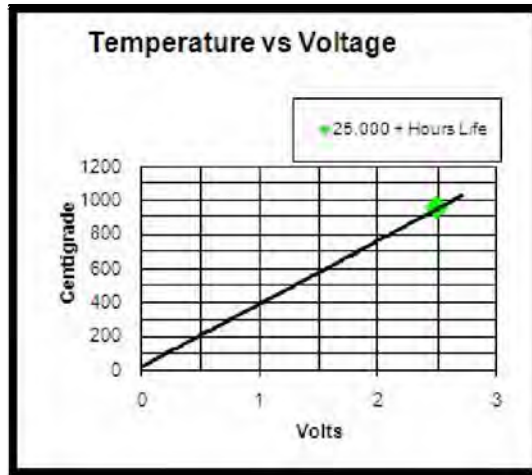

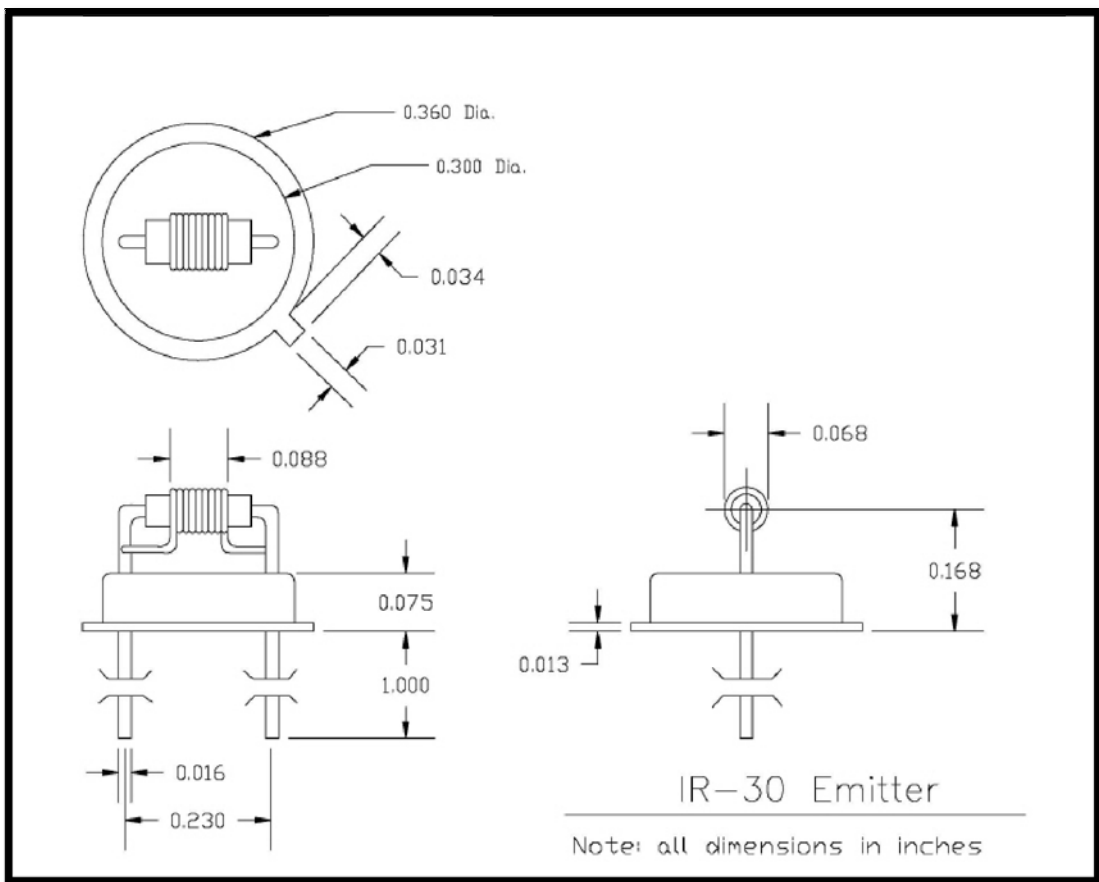

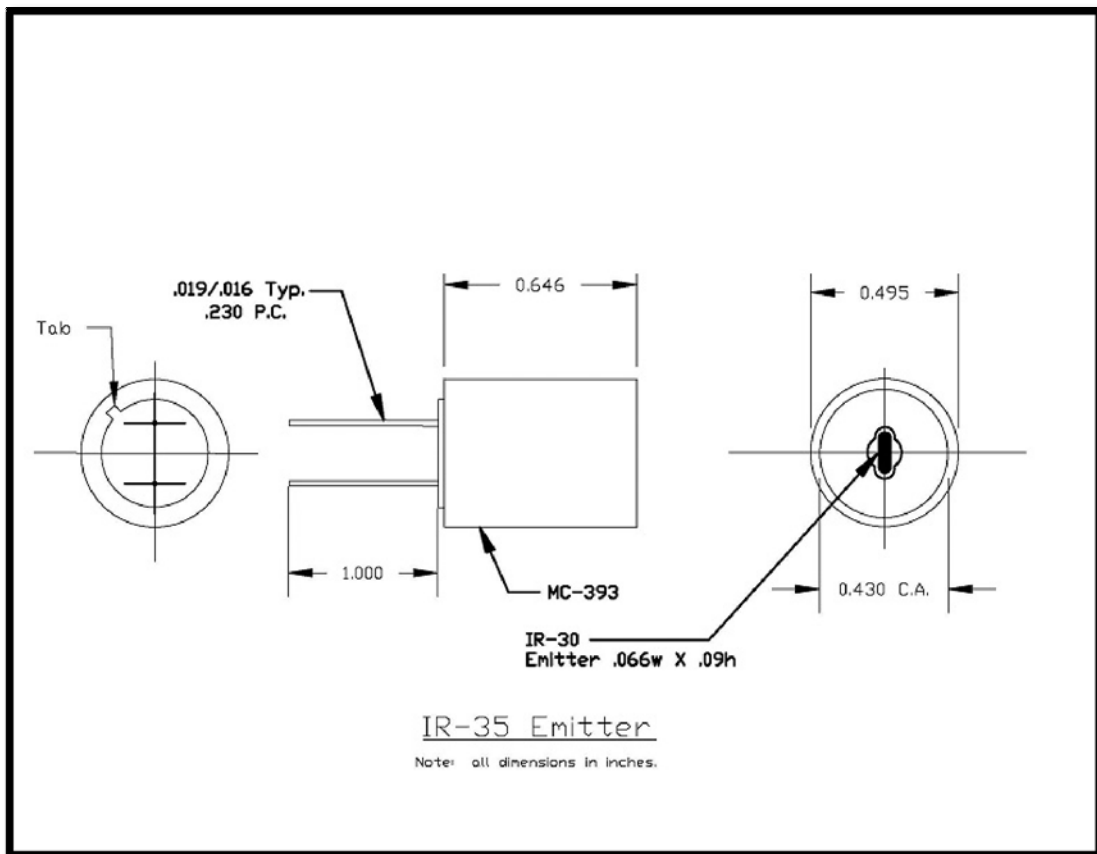



HawkEye Technologies, LLC
Your **Source** for **Infrared**

www.hawkeyetechnologies.com



91 Boylston St, Brookline MA 02446
www.boselec.com irsource@boselec.com,
(617)566-3821

Infrared Source Series 4x

- Thin Film Laser Trimmed
- IR-43 operates at 600°C with 1.3 watts input
- IR-40 operates at 500°C with 2.5 watts input



IR-40NC



IR-43NC

The IR-4x radiating element is an approximately 1.5 micron thin film of precision laser trimmed resistance material which is permanently bonded to a flat substrate of alumina. This contributes to a uniform radiating source and a stable platform. The unit does not require operation in a sealed atmosphere. The thin film design results in a low mass of radiation material.

The IR-40 unit is attached to a TO-5 header with high temperature cement. This unit is also offered without a cap (as an IR-40NC) and with a cap and sapphire window (as an IR-40S). For alternative mounting, it is also offered attached to a flat, butterfly shaped, steel header (as an IR-42).

The IR-43 unit is free standing on a TO-5 header. It requires less power to achieve the same temperatures as the IR-40. Without a directly connected mass to draw off heat, it is more responsive.

Maximum Operating Parameters

	IR-40	IR-43
Voltage	26.0 volts (AC or DC)	14.0 volts (AC or DC)
Temp	500° C	600°C
Current	0.10 Amperes	0.09 Amperes
Power	2.5 watts	1.3 watts
Life	3+ years at 500° C typical	3+ years at 500° C typical
Emissivity	0.80	0.80
Active Area	3.5 mm X 2.5 mm	1.5 mm X 1.5 mm



HawkEye Technologies, LLC
Your **Source** for **Infrared**

www.hawkeyetechnologies.com



91 Boylston St, Brookline MA 02446
www.boselec.com irsource@boselec.com,
(617)566-3821

HawkEye IR-40 Engineering Data Charts

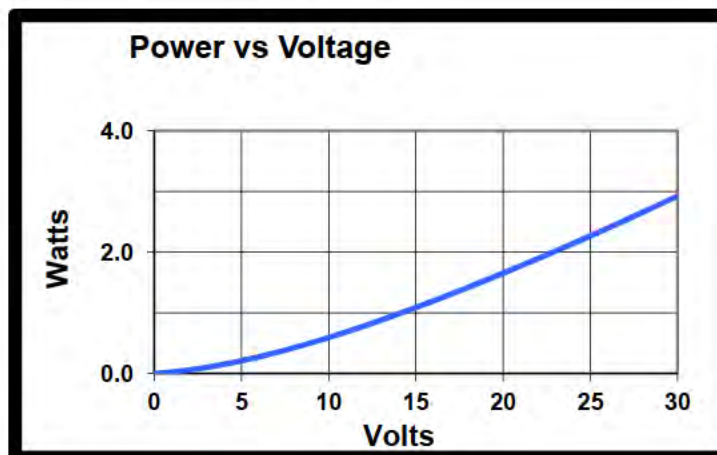
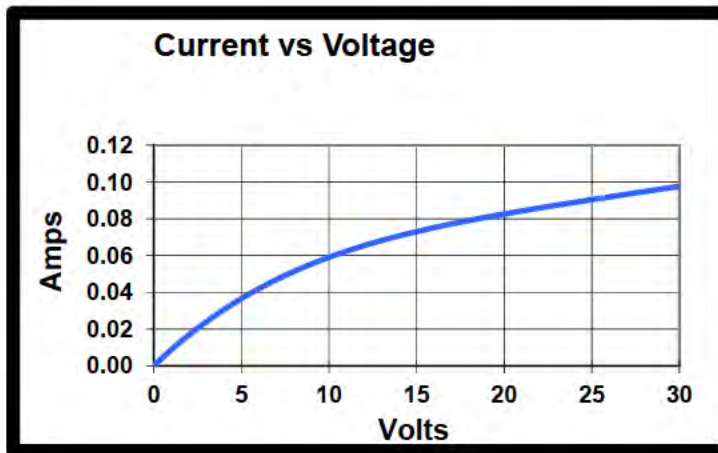
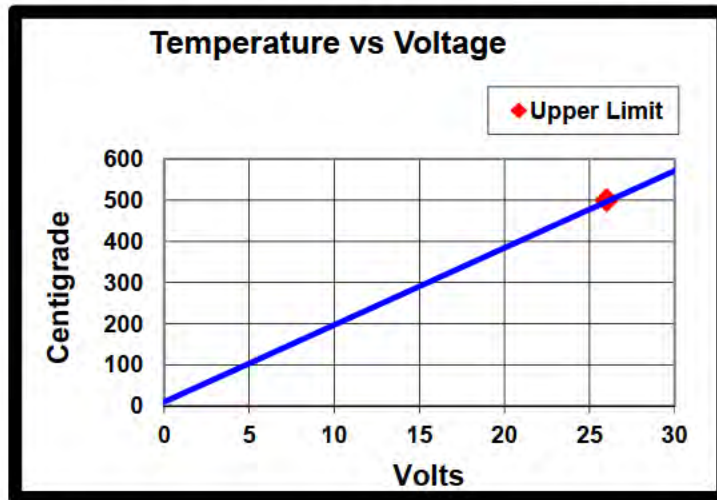



HawkEye Technologies, LLC
Your **Source** for **Infrared**

www.hawkeyetechnologies.com



91 Boylston St, Brookline MA 02446
www.boselec.com irsource@boselec.com,
(617)566-3821

HawkEye IR-43 Engineering Data Charts

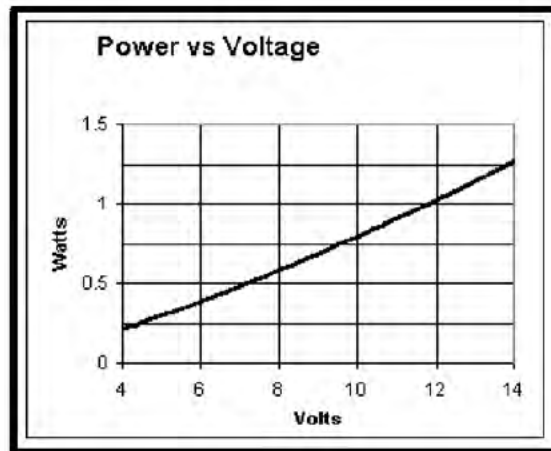
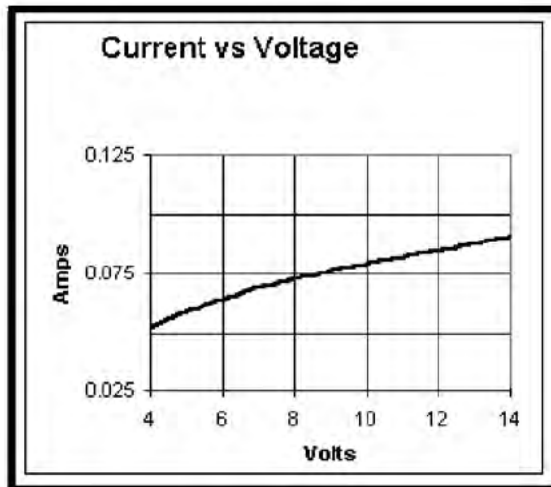
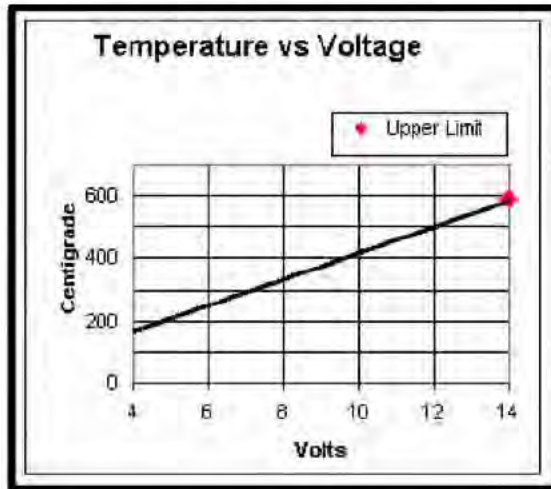



HawkEye Technologies, LLC
Your **Source** for **Infrared**

www.hawkeyetechnologies.com

Boston
Electronics

91 Boylston St, Brookline MA 02446
www.boselec.com irsource@boselec.com,
(617)566-3821

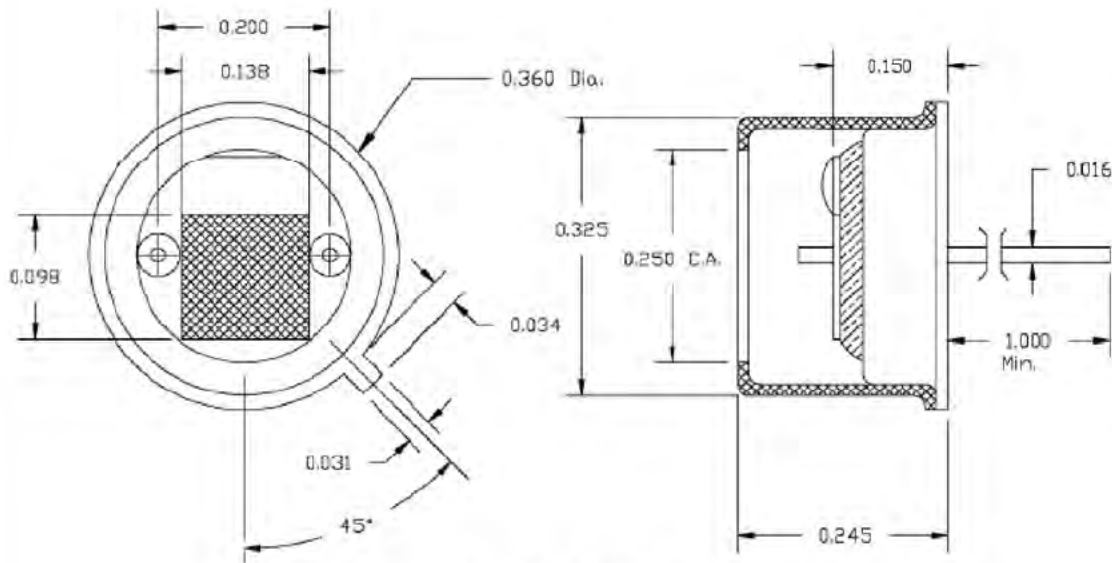

IR-40 Emitter

Note: all dimensions in inches.



HawkEye Technologies, LLC
Your **Source** for **Infrared**

www.hawkeyetechnologies.com

Boston
Electronics

91 Boylston St, Brookline MA 02446
www.boselec.com irsource@boselec.com,
(617)566-3821

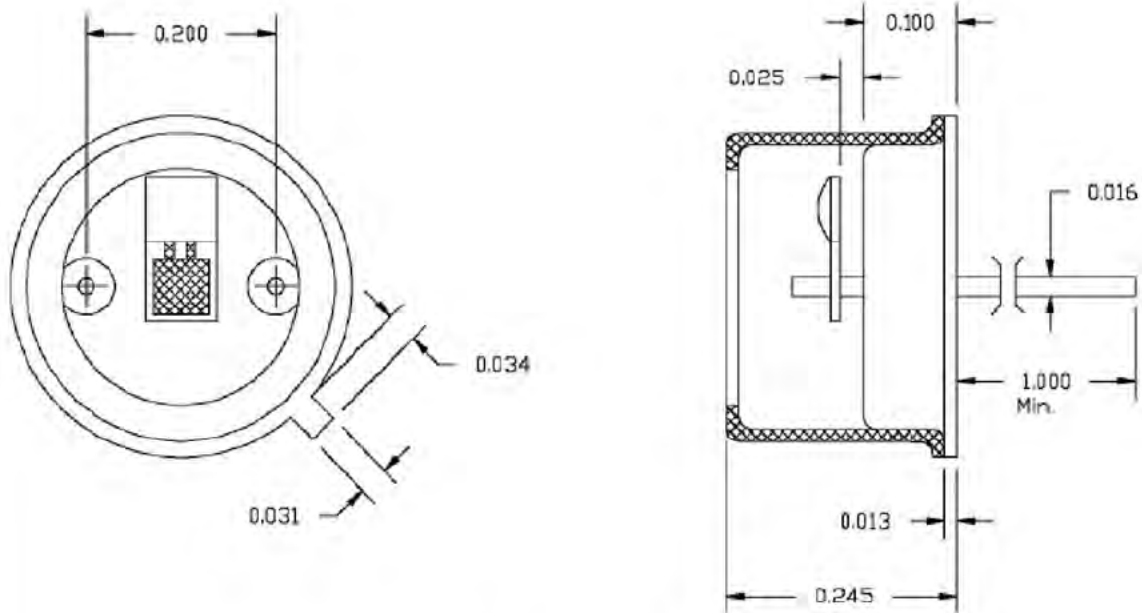

IR-43 Emitter

Note: all dimensions in inches.



HSL Series

Low Cost IR Sources

The HSL Series provides reliable, low cost IR sources for nondispersive infrared (NDIR) gas detection by IR light absorption. In combination with our HTS Multichannel Sensors, they can be used to detect gases like CO₂ or hydrocarbons (HC).

The HSL Series features a small design, good processability and a long lifetime and is available in two versions; either with 60 or 115 mA lamp current.

The IR sources meet all requirements of the European Union RoHS Directive.

Spectral Transmission of Glass Housing

The IR light emittance is strongly influenced by the quartz glass housing of the filament. The transmittance for wavelengths above 4.5 μm is rather low.

Consequently, to detect gases like CO or NO, we recommend using our high performance IR sources provided by the HSL EMIRS Series.

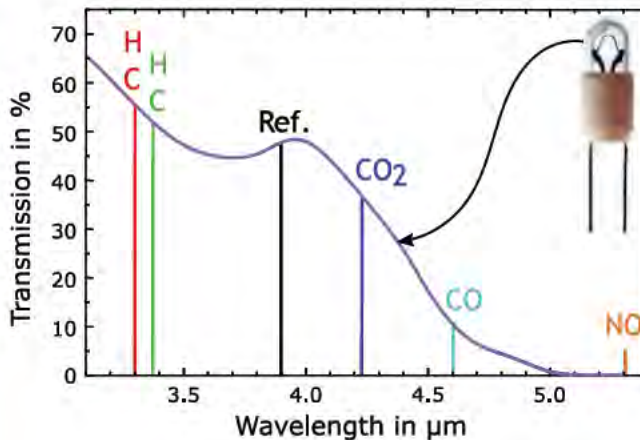

Dimensions HSL 5-60

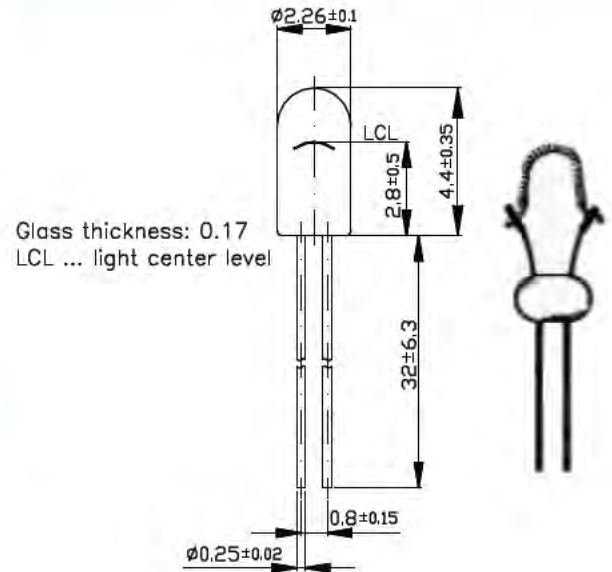

Characteristics

	HSL 5-115 HSL 5-115 S	HSL 5-60	Unit
Supply voltage	5	5	Volt
Current	115	60	mA
Brightness	0.15	0.05	MSCP ^{a)}
Filament	C-2R	C-2R	f
Operating temperature	-20...100	-20...100	°C
Average lifetime ^{b)}	40 000	100 000	hours

a) MSCP (mean spherical candle power) can be converted to lumen by multiplication of MSCP value with 4π (12.57)

b) At 5V, AC

Ordering Information

HSL	Heimann Sensor Lamp
5	Supply voltage
60, 115	Typical current and package size
-, S	Socket or non-socket type

E.g.: HSL 5-115-S
HSL 5-60

Pulsable Sources



HawkEye Technologies, LLC
Your **Source** for **Infrared**

www.hawkeyetechnologies.com



Infrared Source Series 5x

- Wide spectral output
- Fast response
- High pulse rate
- High modulation depth
- High efficiency – low power consumption
- Long life and cost effective
- Custom design – many package options

The HawkEye IR-5x Series is a MEMS technology pulsable infrared emitter. This source is based on patented technology, utilizing a thin film resistor of diamond-like nanostructured amorphous carbon. Due to its low thermal mass, the IR-5x Series can be pulsed at frequencies up to 100+ hertz with good modulation depth (contrast between the on and off states).



The HawkEye IR-50 pulsed infrared emitter in a TO5 header uses a micromachined source chip with a thin, high-emissivity membrane shown schematically below.





HawkEye Technologies, LLC
Your **Source** for **Infrared**

www.hawkeyetechnologies.com



Operational Characteristics for the IR-5x Series

Active Area	1.7 mm x 1.7 mm
Resistance	50 ohms (nominal) in the hot state
Typical Operating Temperature	450°C to 750°C
Drive Voltage at 750°C	6.7 volts +/- 0.4 volts
Frequency at 50% Modulation Depth (25% Duty Cycle)	100 Hz
Spectral Range	1 to 20 microns
Emissivity	0.8 (in the range of 2 to 14 microns)



HawkEye IR-5x Engineering Data Charts

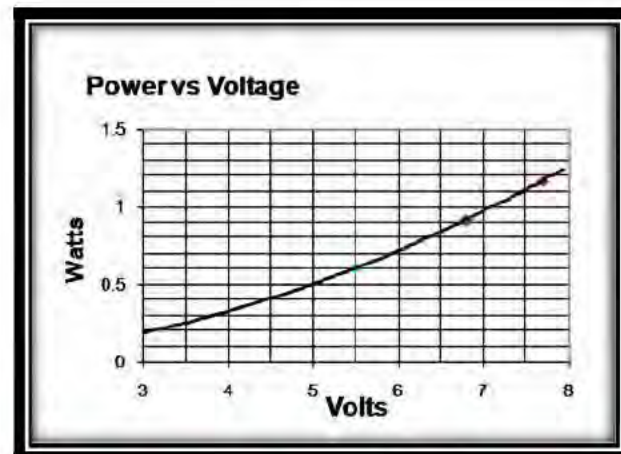
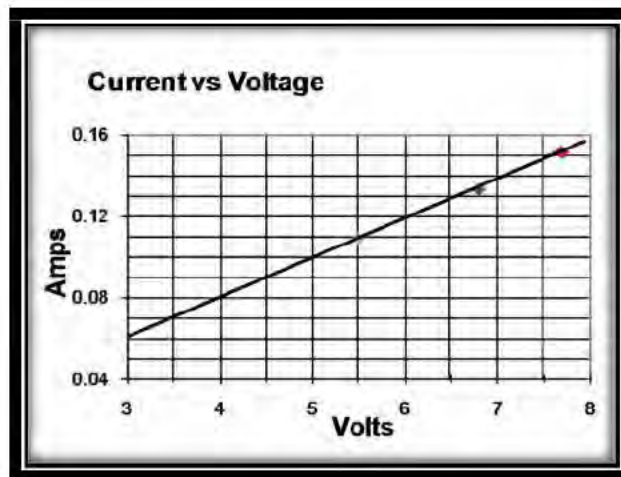
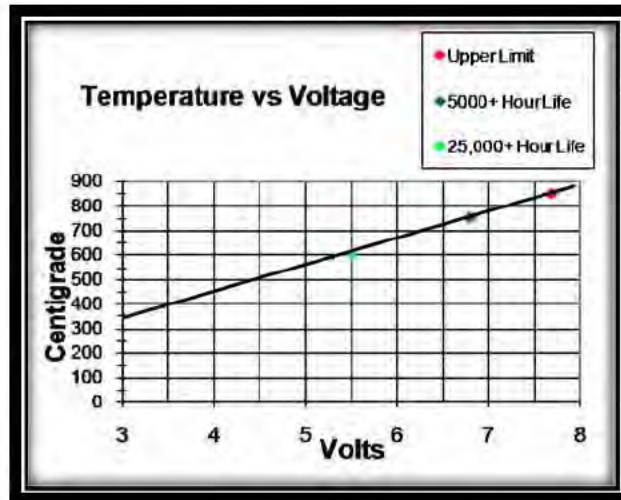







Typical Operating Parameters

	Typical Levels			
Temperature	450	600	750	degrees centigrade
Voltage	4.0	5.5	6.7	Volts (AC or DC)
Current	80	110	134	mAmps
Power Input	0.32	0.60	0.90	Watts
Estimated Life	100,000	40,000	5,000	hours of operation (10 hertz at 50% duty cycle)

Note: The operating parameters assume an infrared source operating without a radiator and at ambient temperature and pressure. A rectangular voltage pulsed at a frequency of 10 hertz and with a duty cycle of 50% is used for heating. If a longer duty cycle (or steady-state operation) is used, lower power levels are recommended in order to achieve the desired temperature. Also, proportionately shorter lifetime would be expected.



Comparison of IR-5x Series Models

	IR-50	IR-55	IR-56	IR-57	Units/Notes
					
Length	0.170	0.646	0.360	1.000	inches
Diameter	0.360	0.495	0.400	1.000	inches
Package	TO-5 with Cap	parabolic optic	parabolic optic	elliptical optic	
Normalized On-Axis Output at 1 inch	1	15	11	NA	
Normalized Angular Output--FWHM	100°	15°	20°	NA	



Operational Guidelines - Infrared Source Series 5x

The HawkEye IR-5x Series utilizes a thin thermoresistive film of conducting amorphous (diamond-like) carbon. Infrared radiation is the result of heating this film by passing an electric current through it.

The maximum temperature of the film should not exceed 750°C in continuous operation. A faint red luminescence of the film is observed during operation at temperatures near 750°C. Short term heating up to 850°C is possible but will reduce the lifetime of the unit.

The operating parameters assume an infrared source operating without a radiator and at ambient temperature and pressure. A rectangular voltage pulsed at a frequency of 10 hertz and with a duty cycle of 50% is used for heating.

Two power leads and a ground are provided per the sketch below. The IR-50 emitter is to be powered through the two power leads. Bi-polar drive voltage may be used. The Case Ground Lead is not required under normal operation.

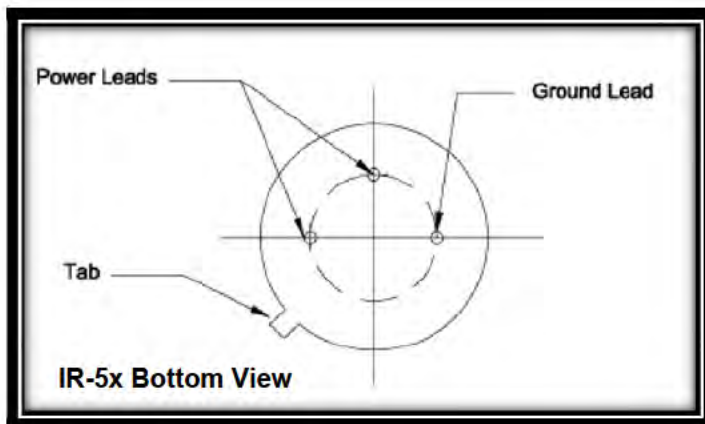



The HawkEye IR-5x Series is the perfect solution for an application that requires fast electrical modulation. However, it can also be used in a steady state (dc) mode. In applications where steady state power is used (or if used with electrical modulation but with a duty cycle of greater than 50%), it is recommended that the nominal input power specifications be reduced in order to avoid overheating of the membrane.

On the other hand, by reducing the length of the heating pulse or by increasing the frequency of modulation, the membrane will not have sufficient time to reach the desired temperature. In this case, the pulsed power can be increased to allow the temperature to be maintained. The chart below shows the factor by which the voltage can be increased as frequency is increased. This chart reflects a 50% duty cycle.

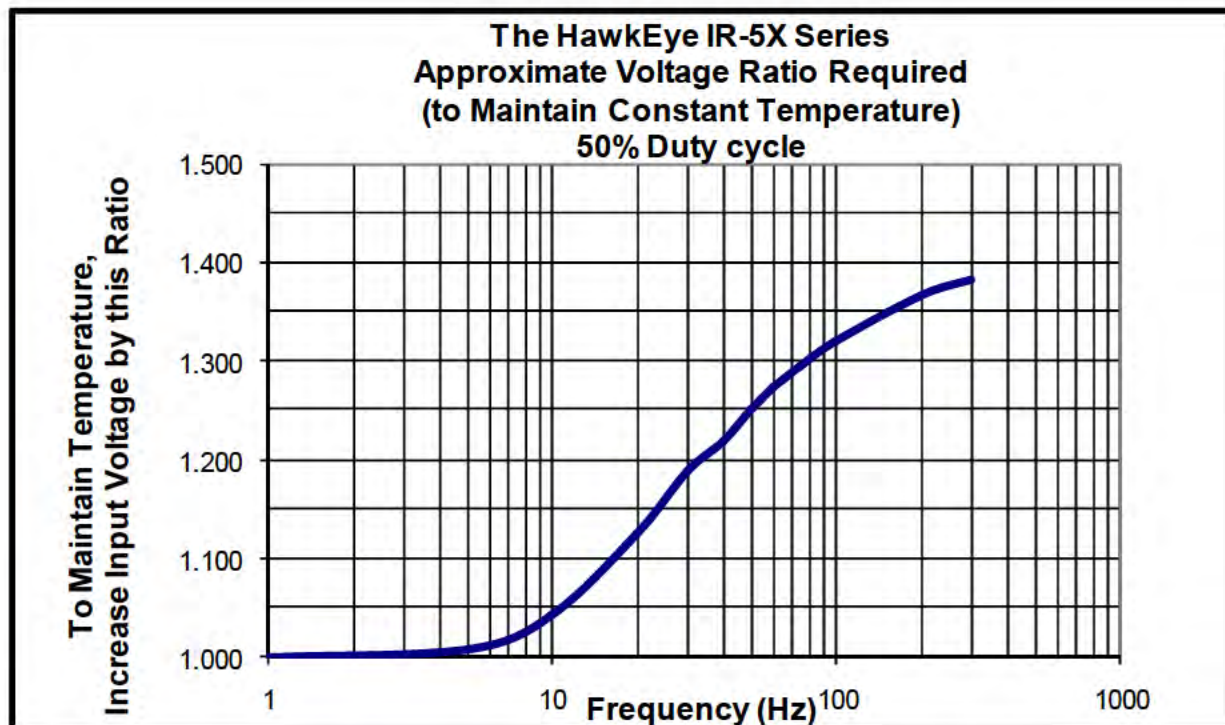



HawkEye IR-50

The IR-50, mounted in a TO-5 base with a windowless cap provides the smallest package and gives the widest output energy beam. FWHM (full width at half max) for the IR-50 is 100°, as demonstrated in the Normalized Angular Output Chart on page 12.

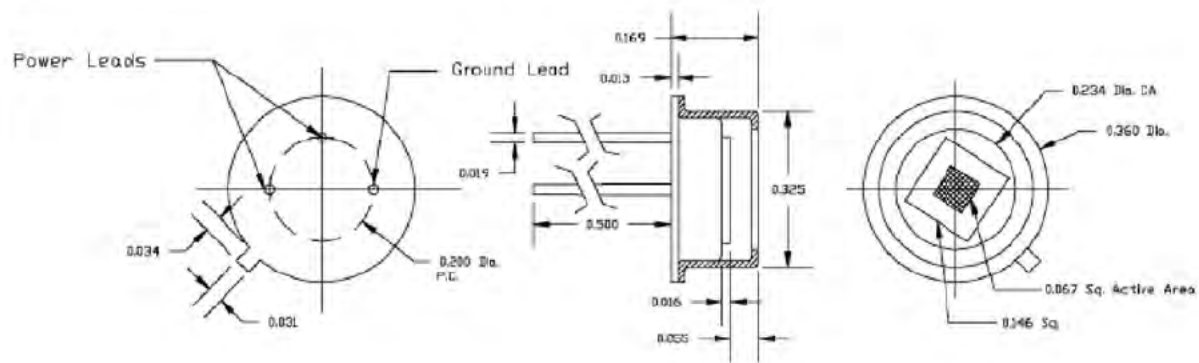

IR-50 Emitter w/Cap

Note: all dimensions in inches.



HawkEye IR-55

The IR-55 utilizes a collimated HawkEye Optic to provide more than 12x the on-axis output. The package is 0.5 inches in diameter and 0.65 inches long. FWHM (full width at half max) for the IR-55 is 15°. See the Normalized Angular Output Chart on page 12.

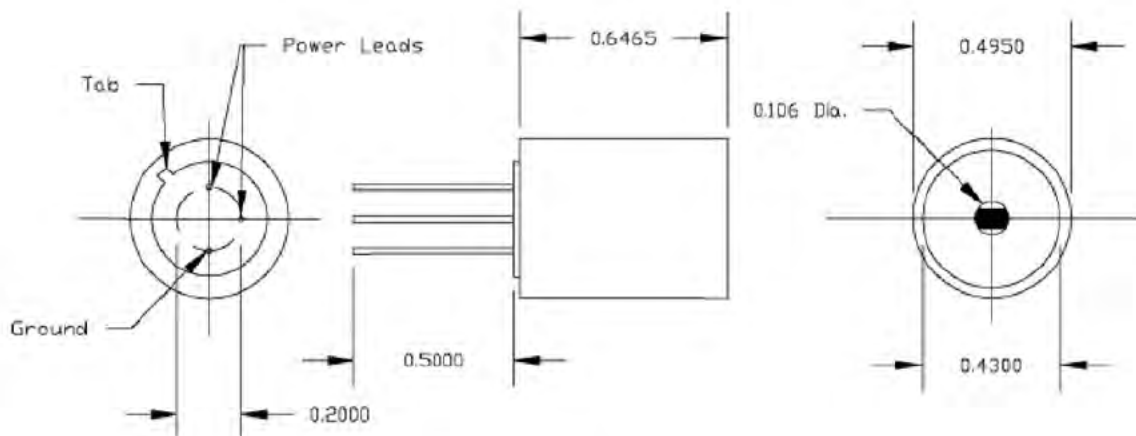

IR-55 Emitter

Note: all dimensions in inches.



HawkEye IR-56

The IR-56 is built upon the same technology as the IR-55, but has just 36% of the IR-55 size. The package is 0.40 inches in diameter and 0.36 inches long. And yet it delivers 50% to 75% of the IR-55 on-axis output energy. FWHM (full width at half max) for the IR-56 is 20°. See the Normalized Angular Output Chart on page 12.

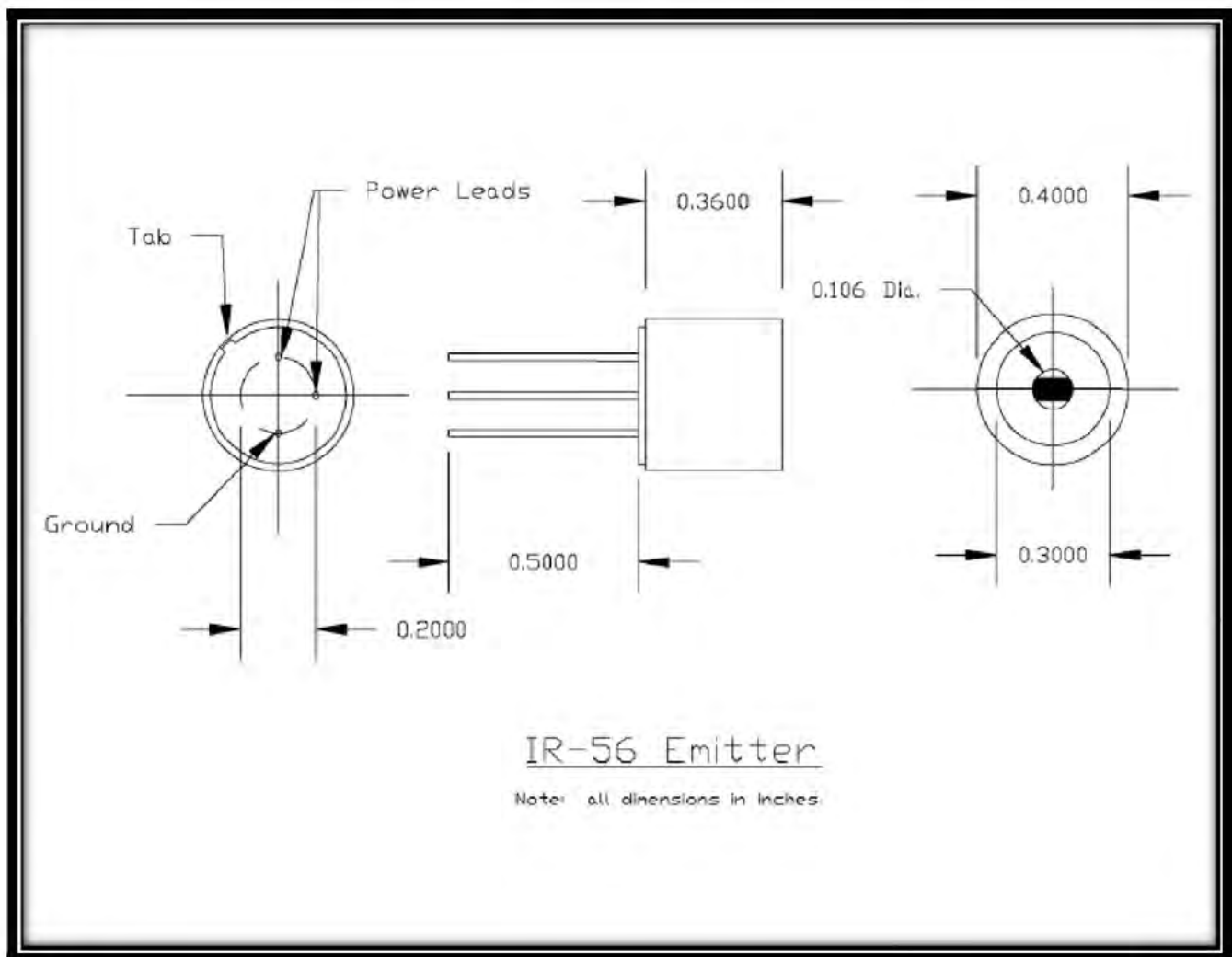



HawkEye IR-57

The HawkEye Technologies IR-57 utilizes a highly efficient elliptical optic to capture and focus the energy of the HawkEye IR-50 Pulsable Emitter. The unit is one inch in diameter and has an external focal point that is $\frac{1}{2}$ inch in front of the clear aperture.

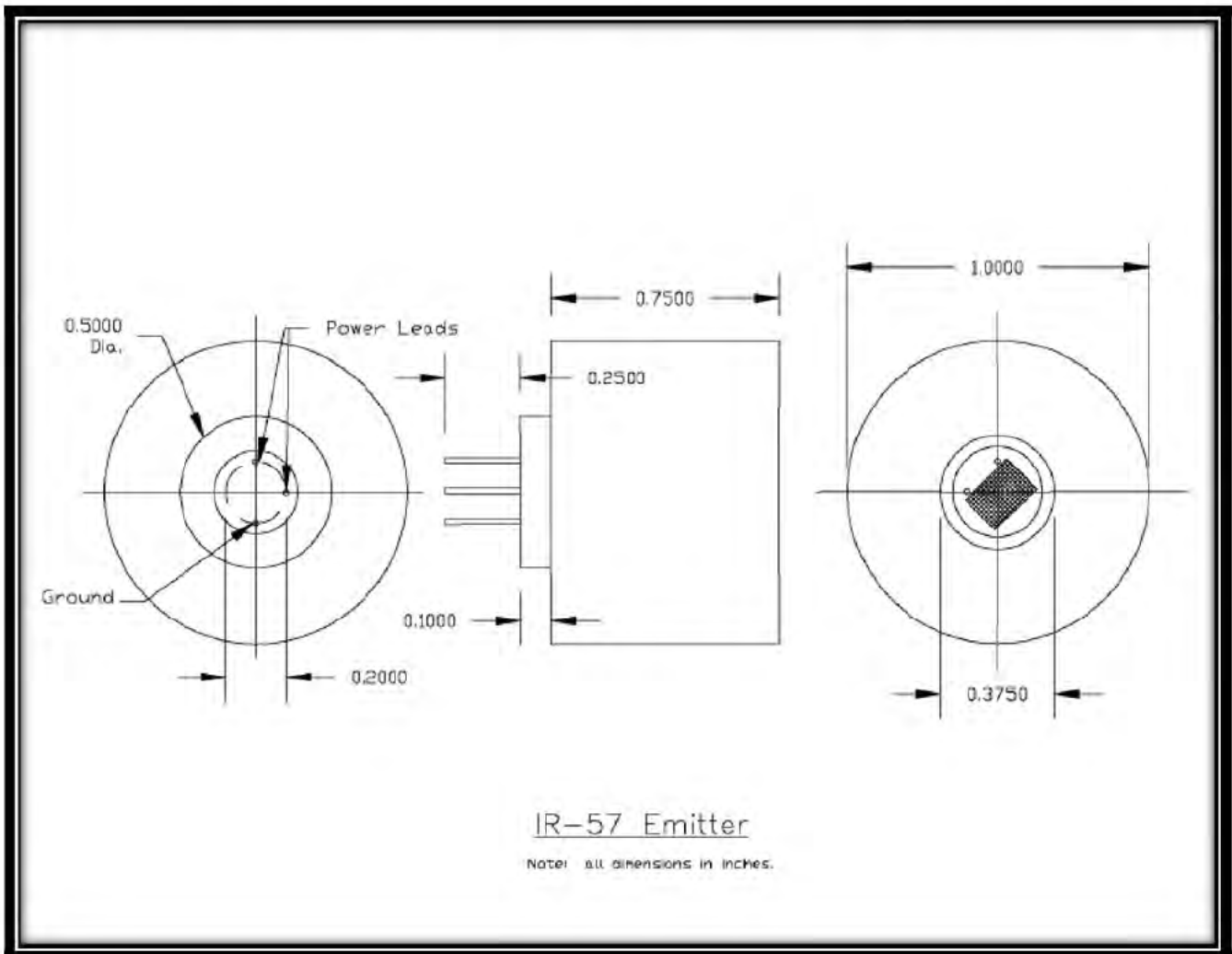



Normalized On-Axis Output

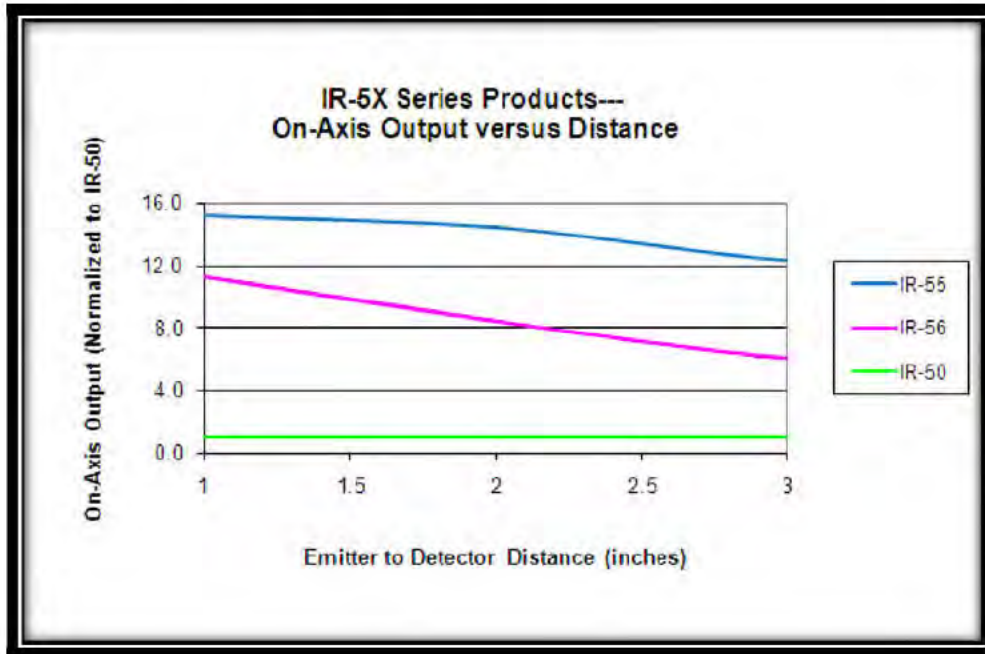

Normalized Angular Output

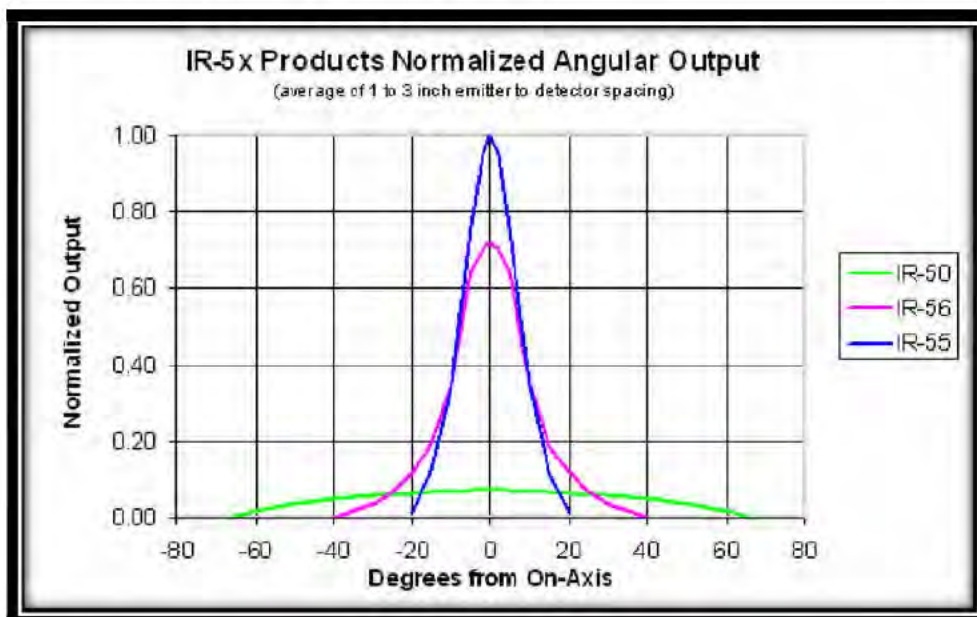



HawkEye Technologies, LLC
Your **Source** for **Infrared**



91 Boylston St, Brookline MA 02446
www.boselec.com irsource@boselec.com,
(617)566-3821

Infrared Source Series 7x

- More on-axis output
- Fast response
- High modulation depth
- Highest efficiency – low power consumption
- Most robust pulsable unit ever!

The HawkEye IR-7x Series is a MEMS technology pulsable infrared emitter. This source is based on patented technology, utilizing a thin film resistor of diamond-like nanostructured amorphous carbon. Due to its low thermal mass, the IR-7x Series can be pulsed at frequencies up to 70+ hertz with good modulation depth (contrast between the on and off states). This exciting new product produces more on-axis output and is more robust than the HawkEye IR-5x, the HawkEye IR-6x or any other pulsable product sold.

Active Area	2.2 mm x 2.4 mm
Resistance	40 ohms (nominal) in the hot state
Typical Operating Temperature	450°C to 750°C
Drive Voltage at 750°C	6.0 volts +/- 0.4 volts
Frequency at 50% Modulation Depth (25% Duty Cycle)	70 Hz
Spectral Range	1 to 20 microns
Emissivity	0.8 (in the range of 2 to 14 microns)
Output	Over 20% greater than the IR-60

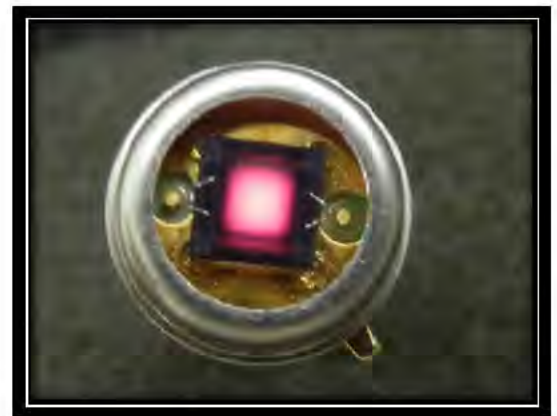

The HawkEye IR-70 pulsed infrared emitter in a TO-39 header uses a micromachined source chip with a thin, high-emissivity membrane assembled using isolation pads for high efficiency and fast response



HawkEye Technologies, LLC
Your **Source** for **Infrared**

www.hawkeyetechnologies.com



91 Boylston St, Brookline MA 02446
www.boselec.com irsource@boselec.com,
(617)566-3821

HawkEye IR-7x Engineering Data Charts

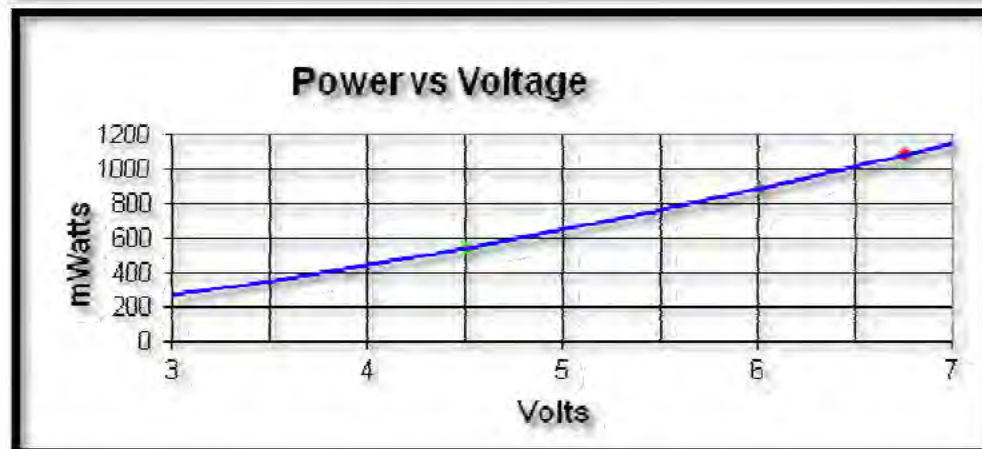
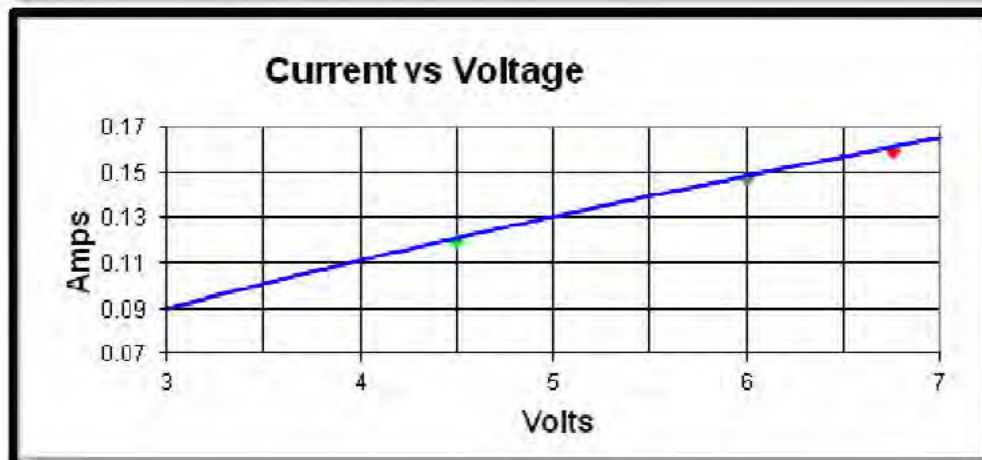
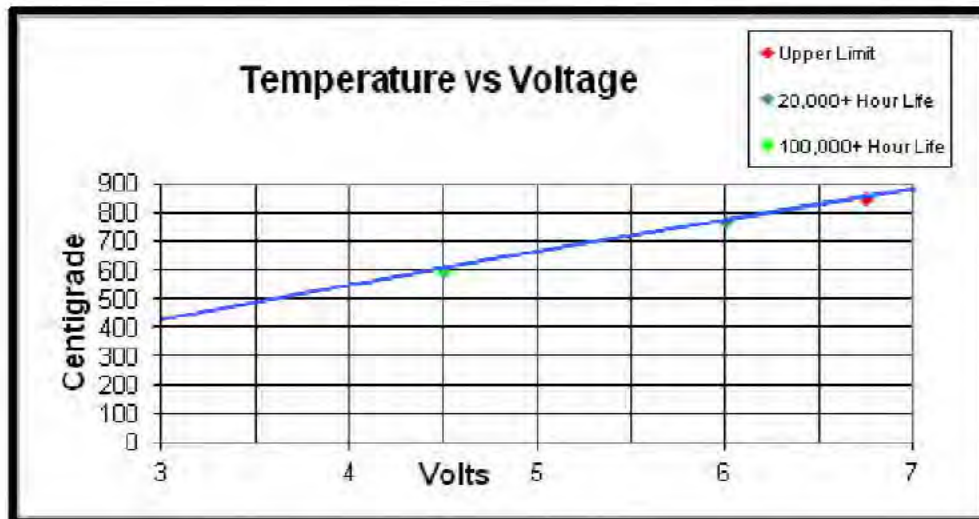

Typical



HawkEye Technologies, LLC
Your Source for Infrared

www.hawkeyetechnologies.com



91 Boylston St, Brookline MA 02446
 www.boselec.com irsource@boselec.com,
 (617)566-3821

Operating Parameters

Typical Levels				
Temperature	450	600	750	degrees centigrade
Voltage	3.0	4.5	6.0	Volts (AC or DC)
Current	90	122	150	mAmps
Power Input	270	550	900	mWatts
Estimated Life	150,000	100,000	20,000	hours of operation (10 hertz at 50% duty cycle)

Note: The operating parameters assume an infrared source operating without a heat sink and at ambient temperature and pressure. A rectangular voltage pulsed at a frequency of 10 hertz and with a duty cycle of 50% is used for heating. If a longer duty cycle (or steady-state operation) is used, lower power levels are recommended in order to achieve the desired temperature. Also, proportionately shorter lifetime would be expected.

			
	IR-70	IR-75	
Length	0.170	0.629	inches
Diameter	0.360	0.495	inches
Package	TO-39 with Cap	parabolic optic	
On-Axis Output at 1 inch	1.6X	23.4X	Indexed to IR-50
Angular Output--FWHM	100°	15°	degrees



HawkEye Technologies, LLC
Your **Source** for **Infrared**

www.hawkeyetechnologies.com



91 Boylston St, Brookline MA 02446
www.boselec.com irsource@boselec.com,
(617)566-3821

Operational Guidelines - Infrared Source Series 7x

The HawkEye IR-7x Series utilizes a thin thermoresistive film of conducting amorphous (diamond-like) carbon. Infrared radiation is the result of heating this film by passing an electric current through it.

The maximum temperature of the film should not exceed 750°C in continuous operation. A faint red luminescence of the film is observed during operation at temperatures near 750°C. Short term heating up to 850°C is possible but will reduce the lifetime of the unit.

The operating parameters assume an infrared source operating without a radiator and at ambient temperature and pressure. A rectangular voltage pulsed at a frequency of 10 hertz and with a duty cycle of 50% is used for heating.

Two power leads and a ground are provided per the sketch below. The IR-70 emitter is to be powered through the two power leads. Bi-polar drive voltage may be used. The Case Ground Lead is not required under normal operation.

The HawkEye IR-7x Series is the perfect solution for an application that requires fast electrical modulation. However, it can also be used in a steady state (DC or CW) mode. In applications where steady state power is used (or if used with electrical modulation but with a duty cycle of greater than 50%), it is recommended that the nominal input power specifications be reduced in order to avoid overheating of the membrane.

On the other hand, by reducing the length of the heating pulse or by increasing the frequency of modulation, the membrane will not have sufficient time to

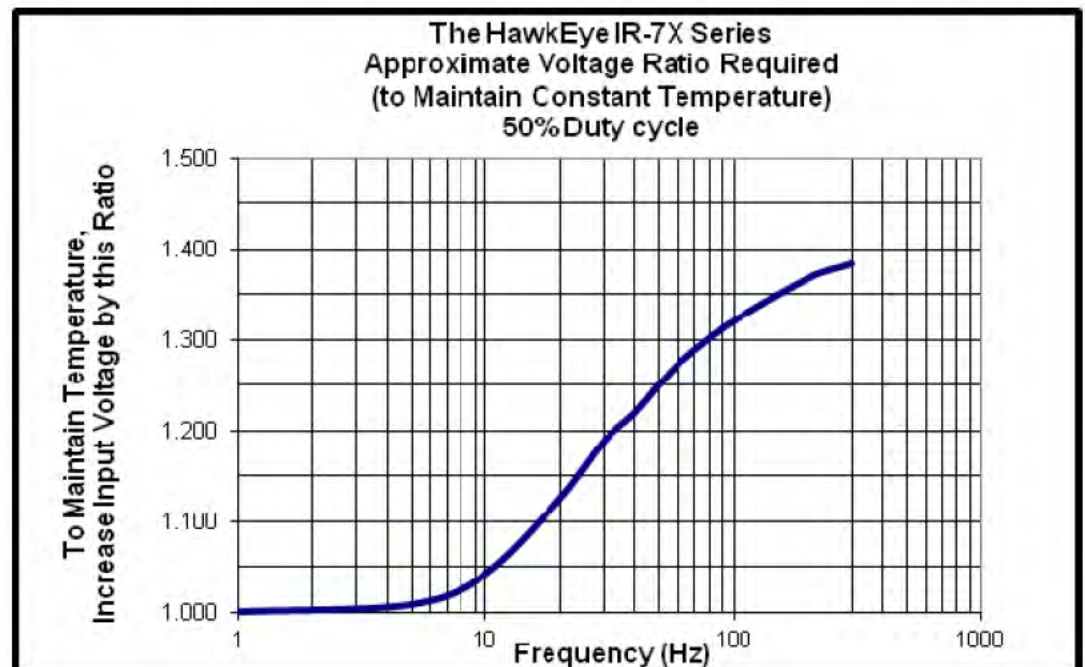



HawkEye Technologies, LLC
Your **Source** for **Infrared**

www.hawkeyetechnologies.com



91 Boylston St, Brookline MA 02446
www.boselec.com irsource@boselec.com,
(617)566-3821

reach the desired temperature. In this case, the pulsed power can be increased to allow the temperature to be maintained. The chart below shows the factor by which the voltage can be increased as frequency is increased. The next chart reflects a 50% duty cycle.

HawkEye IR-70

The IR-70, mounted in a TO-39 header with a windowless cap provides the smallest package and gives the widest output energy beam. FWHM (full width at half max) for the IR-70 is 100°.

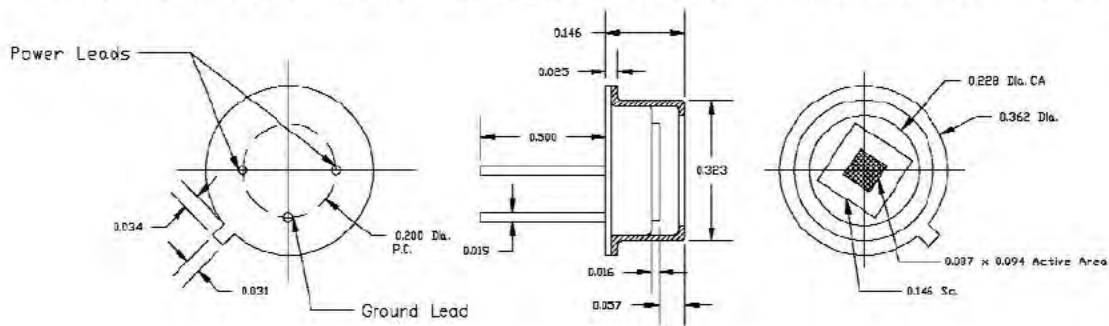

HawkEye IR-75

The IR-75 utilizes a collimated HawkEye Optic to provide approximately 15x the on-axis output. The package is 0.5 inches in diameter and 0.63 inches long. FWHM (full width at half max) for the IR-75 is 15°. The combination of fast electrical modulation, low input power requirements and great on-axis output places this unit clearly in a class of its own!

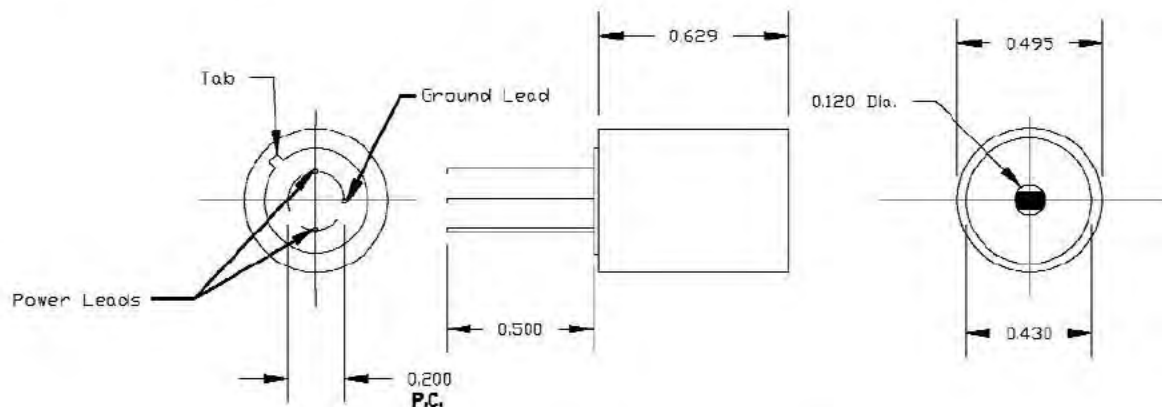

IR-75 Emitter

Note: all dimensions in inches.

Other Sources - HelioWorks

contact us for availability

Helioworks - Pulsable and Steady State Infrared Sources

Helioworks, Inc. has a broad capability in the design and manufacture (including coil winding) of steady state and pulsable infrared sources utilizing Tungsten, NiCr, and Kanthal filaments. If our standard models do not meet your needs, please let us know your requirements.

Pulsable & Steady State EP Series – Tungsten Filament

Tungsten achieves the highest temperature and power of any practical material and is therefore a valuable source of infrared emission. However, to make a source of intense infrared emission using tungsten, another protective window must be used. State-of-the-art, patented incandescent IR sources developed by Helioworks utilize sapphire because of its high transmission in the near infrared. The uniqueness of our product is the integration of the sapphire window with the tungsten filament. This allows high power transmission in the near infrared.



Key Features:

- Pulse or steady state
- Long term stability
- Desirable signal-to-noise ratio
- Large temperature modulation in pulse mode at elevated frequency
- Latest technology in packaging and window options

Tungsten filaments are provided in a variety of sizes to accommodate various frequency and modulation requirements. Operating temperatures up to 1900°K are standard with the EP-series source.

In the Steady State version tungsten filaments are wire wound in the form of right cylindrical coils of various diameters and length and operate with constant low voltage DC input for long life. All include gold plated parabolic reflectors and an inert gas backfill.

TO-8 Package				
Model	Pk Volts	Pk Current (A)	Pk Power (W)	Window
EP-3872	2.20	1.10	2.40	Sapphire
██████	████	████	████	██████
EP-3963	3.00	1.00	3.00	Sapphire
EP-3964	3.50	1.00	3.50	Sapphire
EP-3965	3.50	2.00	7.20	Sapphire
EP-4317	5.00	2.10	10.50	Sapphire

Pulsable IR Sources

EF Series – NiCr Filament

Nichrome (NiCr) filaments are made from ultra-thin metallic strips. The metallic strips have a very high surface to volume ratio and thus a very short thermal time constant. They heat up and cool down or modulate very rapidly. The elements are typically attached in a series configuration to increase the overall resistance of the emitter (EF-series).



Window options denoted by X include: No Window (X=0), Sapphire (X=1), CaF2 (X=2), ZnSe (X=3)

Key Features:

- NiCr filament with emissivity of 0.88
- Uniform emitting area and temperature
- NiCr filaments operate at peak temperature of 700°C (973°K)

TO-8 Package				
Model	Pk Volts	Pk Current (A)	Pk Power (W)	Window
EF-852XR	2.00	1.30	2.60	X= 0, 1, 2, 3 see above
EF-853XR	3.00	1.30	4.40	X= 0, 1, 2, 3 see above

Note: Delete the "R" to exclude a reflector

Steady State Infrared Sources

EK Series – Kanthal Filament

Kanthal filaments are wire wound in the form of right cylindrical coils of various diameters and length. All the Kanthal based lamps (EK-series) operate in steady state with constant low voltage DC input for long life.



Window options denoted by X include: No Window (X=0), Sapphire (X=1), CaF2 (X=2), ZnSe (X=3)

Key Features Include:

- Kanthal filament with emissivity of 0.7
- Window options including no window, CaF₂, ZnSe
- Internal gold plated parabolic reflector
- Industry standard TO-3, TO-5, or TO-8 packages
- Inert gas backfill

TO-8 Package				
Model	Pk Volts	Pk Current (A)	Pk Power (W)	Window
EK-827X	1.20	1.08	1.30	X= 0, 1, 2, 3 see above
EK-837X	1.40	1.75	2.45	X= 0, 1, 2, 3 see above
EK-852X	3.00	1.48	4.40	X= 0, 1, 2, 3 see above
EK-862X	3.50	2.40	8.40	X= 0, 1, 2, 3 see above
TO-3 Package				
Model	Pk Volts	Pk Current (A)	Pk Power (W)	Window
EK-343X	4.00	2.96	11.84	none (x=0)
TO-5 Package				
Model	Pk Volts	Pk Current (A)	Pk Power (W)	Window
EK-527X	1.20	1.08	1.30	X= 0, 1, 2 see above
EK-537X	1.40	1.75	2.45	X= 0, 1, 2 see above

Match the Emitter to the Task

BRIAN ELIAS, CAL SENSORS INC.

Often a scientist or engineer is tasked with developing a spectroscopic system for which he must choose a source. He may know exactly which architecture, dispersive element, slit size and sensor the application requires, but he may be left to the mercy of marketing propaganda when it comes to the selection of the infrared source. Should he depend on the old reliable technology or venture into a new and innovative source – and what are the benefits? Maybe a lightbulb would work.

The easy way is reviewing the technologies of each emitter type and selecting a specific spectroscopic application.

The use of infrared is expanding as applications that address cost, quality or security issues are developed. Some applications rely on the generation of IR energy from the object itself, but these are rare. Most spectroscopic measurements rely on reflection from, or transmission through, a sample, with the resultant absorbance spectra measurement being made on the transmitted energy. These require sources of IR energy that have characteristics based on the application, on the spectrometer design or on the detector used.

Two choices

Infrared sources or emitters can be broken down into two general technologies: quantum and thermal emitters.

Thermal emitters generate photons by heating material. They are, by nature, broadband emitters whose output characteristic is determined primarily by the temperature of the element as described by Planck's law. Characterized by high output power, they have long been the standard source for IR spectroscopy. Thermal emitters can be pulsed but require careful design to overcome the intrinsic thermal mass of the heated filament.

Quantum emitters – laser diodes, IR LEDs, etc. – offer good efficiency and can output well into the IR region. They are useful in spectroscopic applications where a monochromatic source is sufficient or preferred. They offer long lifetimes and high pulse rates in modulated applications.

To determine adequacy for a particular application, each of these technologies can be evaluated by the following parameters: size, efficiency, output power, drive requirements, stability over time, cost, lifetime and pulse rate (for modulated applications).

In addition, some detector technologies dictate the type of source used in a system based on their characteristics; for example, because pyroelectric detectors have slow response to incident radiation, a fast-pulsing source would not be appropriate.

Thermal emitters, also called incandescent emitters, heat material to a point where photons are emitted. Modern thermal emitters have their basis in blackbody radiation and typically are characterized by their emissivity (ϵ), which is defined as the ratio of the radiant emittance of a source to the radiant emittance of a perfect blackbody at the same temperature. Although metals commonly are used as source elements for thermal emitters, they typically have very low emissivity values in the range of 5 percent. A relatively simple process of oxidization can increase their emissivity to more than 80 percent, at which point they have sufficient emissivity to be used as thermal radiators.

Thermal emitters have the advantage of broadband emission and the disadvantages of slow speed – for pulsed applications – and of high drive-power requirements. Some applications rely on a simple tungsten bulb for a source, but the glass or quartz bulb material used often does not transmit the longer wavelengths; for example, quartz

transmits only 50 percent of its peak value at 4.3 μm . Recent advances in several areas have brought improvements in dedicated thermal emitters that enhance their use in a variety of broadband applications. MEMS technologies now can produce both spectral and blackbody emitters with very small size and fast pulsing – thanks to the low mass of the emitter – with a resultant limitation of low output power. Deposited film emitters offer a compromise between fast pulsing rates and high power output. In addition, advances in filament emitters have resulted in high pulsing speeds with high output power and long lifetimes.

Several filament configurations for thermal emitters, each with their advantages and disadvantages, direct the designer of spectroscopic systems to choose one over the other.

Wound Filament: These emitters provide high power output with relatively low cost and high reliability. They can have a solid or air core, with the former material typically ceramic. In its basic form, the air core wound filament emitter is similar to a lightbulb. The dedicated IR emitter's advantage is that it can generate IR photons, so all of the materials are designed with that in mind. A ceramic core often is added to produce a more uniform output because the filament heats the core, thus radiating photons. In some multielement detector systems, air core wound emitters can be problematic because the filament coils are imaged on the detector and produce a nonhomogeneous flux field.

The filament material is a resistance wire, often NiCr, or a variety of wires produced by Kanthal AB that are FeCrAl alloys and that offer high-temperature operation (1350 °C for Kanthal A) and long life. Because of the large mass of the source, wound filament emitters do not lend themselves to modulated applications. Any modulation would require mechanical means, such as an optical chopper.

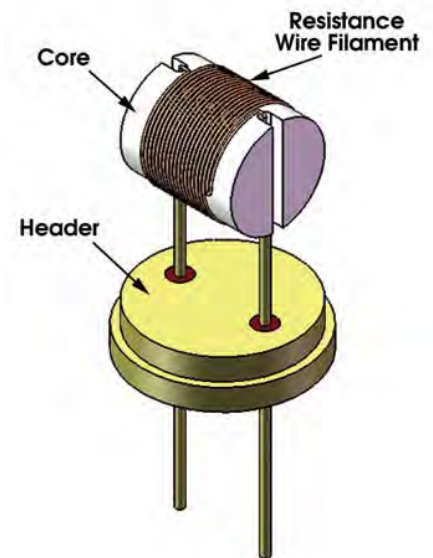

Ribbon Filament: The pulsing speed of an incandescent filament depends on the rate at which the filament can be heated and at which the heat can be removed. Addressing this problem involves the analysis of all aspects of the energy cycle, including filament mass, photon direction, filament “heat sinking” and power-drive design. Ribbon filament emitters are mechanically simple devices, making them cost-effective and reliable. Although tungsten often is used as the filament material, it has very low emissivity, particularly in the infrared, so surface treatments must be applied to enhance the emissivity, and the atmosphere must be carefully controlled to eliminate further emissivity changes resulting from atmospheric interaction. Hermetic sealing with a thermally conductive backfill gas ensures filament emissivity stability as well as a maximum cooling rate during the cooling cycle of the pulsed operation.

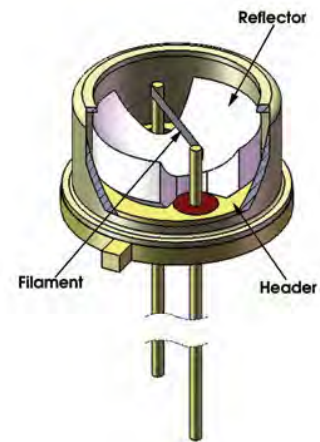

Reflectors often are used – as with the wound filament emitters – to direct all possible radiation out of the package, particularly in vertically oriented filaments.

During the “On” part of the pulsed cycle, it is important to impart as much power to the filament as possible without overstressing it from film evaporation at localized heating points. Careful design of the drive wave form and backfill environment can enhance the pulse rate and modulation depth significantly. Careful control of these parameters has produced emitters with pulse rates of nearly 200 Hz at a modulation depth of 50 percent. The emitters also can be operated as steady-state sources and do not have the coil imaging problems associated with wound filament sources.

Deposited Filament: Further reduction in filament mass for a high pulsing rate can be achieved through deposition methods. By their nature, deposited film emitters require a substrate to be the mechanical support mechanism, unlike the ribbon filament, which is self-supporting. The deposited filament emitter consists of a film of electrically resistive material deposited onto a substrate of thermally resistive material. The deposited film can be any material that is compatible with film deposition techniques and that has sufficient resistance and emissivity. It also must withstand the high temperatures associated with incandescent photon emission.

Metals such as tungsten have been used, as have various configurations of silicon, where the resistivity is controlled by doping. Doped polysilicon filaments present some problems with dopant migration and often cannot operate at temperatures sufficient for near-IR spectroscopy. A nonmetallic filament's advantages are that the materials can have higher resistivity and that the drive current requirement is correspondingly lower.

The advantages of the deposited filament source are fast pulse rate and a relatively low cost, depending on the material used. High-volume substrate processing can produce high volumes at relatively low cost. The disadvantage is that the small filament size results in low output power, and for pulsing applications, the thermal mass of the substrate reduces the pulsing speed.

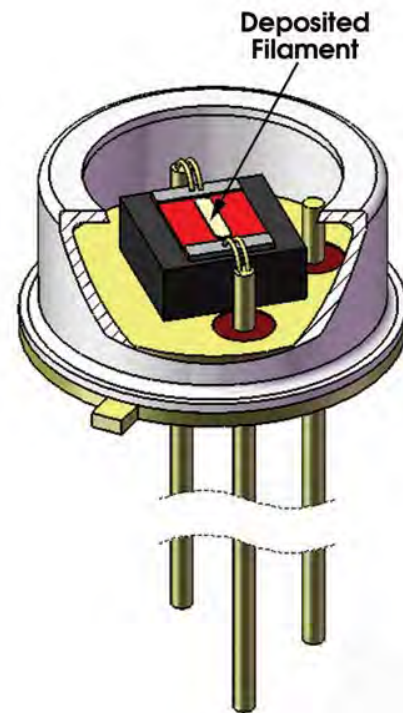

Incandescent emitter failure

A major failure mechanism in incandescent filament emitters is evaporation of the filament, which has two effects that decrease emitter lifetime. As the filament evaporates, it becomes thin, often nonuniformly, because of localized heating resulting from the increased spot resistance. In addition, the evaporated filament deposits onto the window material, decreasing the optical output and increasing the internal temperature of the emitter. Operating these emitters at lower temperatures greatly increases their lifetime. For pulsing emitters, the trade-off always is between low-mass filaments for rapid modulation and sufficient lifetime.

Microelectromechanical systems

Microelectromechanical systems (MEMS) techniques are being used in a wide array of applications, including IR emitters, to enhance performance using micromachining methods previously not possible. MEMS devices targeted at specific wavelengths or wavelength ranges are available in both thermal (blackbody) and spectral emitter configurations.

A typical thermal MEMS emitter is like the deposited filament emitter, with the added benefit that the substrate on which the filament is deposited can be made into a very thin member. This greatly reduces the thermal mass of the system and enhances the modulated performance.

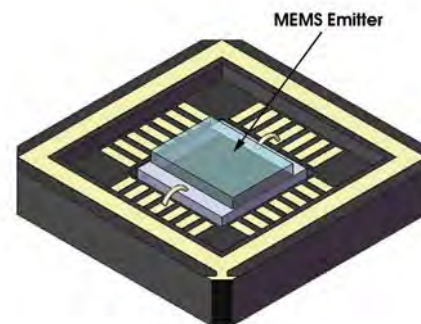

Many filament materials have been used, including traditional metals and polysilicon. MEMS techniques have produced single-crystal silicon filament sources that can operate at 1200 K with 10.7 mW of total radiated power from a 1-mm² emitter. Other filament materials used are diamondlike carbon or diamondlike nanocomposites, which are durable and have widely variable electrical conductance properties.

MEMS techniques also have produced spectral emitters with methods using, for example, photonic crystals. Although spectrally limited emitters are not appropriate for broadband spectroscopy, they can be advantageous in

spectral analysis of fixed compounds, eliminating the need for band-limiting optical filters.

Quantum emitters

Whereas thermal emitters generate photons by heating a filament material, quantum emitters generate them by the recombination of electrons and holes across a semiconductor bandgap. The energy of the photon emitted is equal to the difference between the recombined electron-hole pair; thus its wavelength is determined by the host semiconductor material. The bandwidth can vary from fairly wide in the case of pumped infrared LEDs to very narrow in the case of a laser diode. This can be advantageous to some spectroscopic systems, eliminating the need for optical filters to differentiate wavelengths of interest. These devices are not practical in systems that require wideband, high-power infrared radiation.

IR LEDs: These components have been developed with wavelengths well into the near-IR spectrum, with continuous power outputs of approximately 1 mW and pulsed power in the tens of milliwatts for wavelengths to 2.2 μm . Higher-wavelength LEDs are available, but the power output is in the microwatt range.

To extend the wavelength range and increase the power output, pumping techniques are used whereby a lower-wavelength source (LED or semiconductor laser) is used to excite a material with a bandgap in the wavelength of interest. The excited material then emits photons at a longer wavelength. This technique can increase the output power 20 times over that of standard LEDs at wavelengths greater than 3 μm .

Laser Diodes: Because of the process of stimulated emission of photons, a laser diode has an even narrower bandwidth than a conventional LED. In addition, laser diodes can have power outputs in the milliwatt range, making them appropriate for applications that require a high-power, narrowband source. Quantum cascade lasers can produce tens or hundreds of milliwatts in pulsed mode into the far-IR.

Quantum emitters offer high speed and efficiency but are not suited for broadband spectroscopic applications. Thermal emitters are well-suited spectrally for broadband applications, with outputs closely approximating Planck's blackbody curve. Advances in technologies such as micromachining and in applications of existing physics have led to thermal radiators that have a long lifetime as well as relatively high pulsing speeds with high modulation depth.

In addition, cost is always a criterion for any practical system, and solutions that are more exotic are more expensive, but prices will decrease as technology advances. All of these developments improve the quality of spectroscopic systems but require the designer to carefully consider the trade-offs when selecting a specific emitter technology.

Meet the author

Brian Elias is director of engineering at Cal Sensors Inc. in Santa Rosa, Calif.; e-mail: brian@calsensors.com.

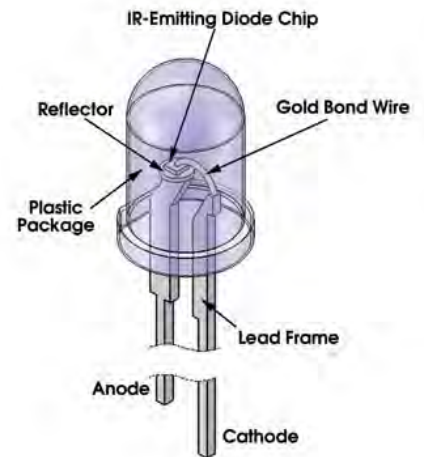

History

In 1860, Gustav Kirchhoff used the term “blackbody” to refer to an object that perfectly absorbs and thereby perfectly emits energy. In 1894, Wilhelm Wien developed his displacement law, which provided the general form of the equation for the spectral distribution of the radiation from a blackbody. Unfortunately, it agreed only with the experimental data at short wavelengths. In 1900, Lord Rayleigh derived an expression that fit the experimental data

for long wavelengths, but his expression predicted that energy would increase without limit as the wavelength decreases, earning it the dubious distinction as the “ultraviolet catastrophe.” Max Planck interpolated between Wien and Rayleigh to provide a radiation formula that was valid at all wavelengths. He presented his paper to the German Physical Society on Oct. 19, 1900. This introduced the concept of quantum physics.



Boston Electronics offers a large variety of infrared light sources. Choosing the right one among many can be a chore. This sheet is intended to help you make your choice quicker and easier.

Calibration Grade	See our Calibration Grade Source catalog for cavity blackbody sources and extended area sources. NIST traceable.	Cavity blackbody sources from 50 to 1200C. Extended area sources from -30C to +500C.
Instrumentation Grade – for Non-Dispersive IR (NDIR) gas concentration measurements typically	See our Quantum Cascade Laser catalog for details of tunable IR lasers for precision spectroscopy from 4 to 15 ⁺ μm.	DFB lasers with linewidths < 0.001 cm ⁻¹ . External cavity lasers with 1 cm ⁻¹ resolution; high power sources > 1W.
	See our Miniature IR Sources catalog for compact thermal sources for <3 to 15 ⁺ μm.	A wide range of choices differentiated by mechanical package format and by power. Simple and low cost.
	See our IR LEDs catalog for low power LEDs for 2 to 7 ⁺ μm.	Turn on and off in nanoseconds but less spectrally bright than thermal sources.
Heaters	We do not offer sources powerful enough to be used as radiant infrared heaters.	Consider using tungsten-halogen lamps, widely available from other vendors.

“Efficiency” of thermal radiation sources, especially those intended to produce energy in the infrared. Specifically, this relates to electrical resistance heaters, analogs of the old tungsten filaments light bulbs but operated at lower temperatures and producing comparatively little visible light.

- Conservation of energy says that the radiative heat output **P** must equal the electrical energy input. Here we mean “heat” to include visible light, light at all wavelengths, emitted according to the black body laws.
- The device materials are not perfect black body emitters. Emissivity does vary with wavelength and is not well known, but emissivity **ε** around 80% is accepted as typical.
- In addition to radiative heat output, every real-world device will have parasitic heat loads **L** due to CONDUCTION through the device structure and CONVECTION in any atmosphere that surrounds the device. We have no obvious way to get a good estimate of the parasitic conduction and convection losses but note that convection and conduction are understood to be linear processes versus absolute temp **K**, while radiative output is proportional to **K⁴**. Therefore radiative transfer is more important at raised (operating) temperatures and dominates. For want of a better number, 80% is proposed as a placeholder.
- Not all wavelengths that are emitted by the hot source are useful to the project. For example, an NDIR gas concentration measurement at 3.3 microns or at 4.27 microns would find that less than 1% of the total black body energy from a 700C emitter would be useful in the measurement. The same < 1% spectral fraction **S** is true for a 1000C emitter although the total useful power does double with the increase in temperature.
- The energy is radiated into at least 2π steradians and up to 4π steradians. How much of it gets to a place that is useful to the user’s task is a function of the user’s optical set up **O** is difficult to estimate in general but is unlikely to be higher than 20%.

SUMMARY: for the example wavelengths of 3.3 and 4.3 microns with IR thermal source temperatures of 700 C or 1000C, our estimate of how much of the total electrical power **P** would be useful **U** is

$$U = P * \epsilon * L * S * O$$

1000 milliwatts becomes $< 1000 * 0.8 * 0.5 * 0.01 * 0.2 = 0.8$ milliwatts in this example. In terms of “efficiency” for the task, < 0.1% looks hard to beat.

As a comment, IR LEDs will have similar spectral efficiency, less parasitic heat to manage, and superior optical beam forming qualities as well as being electronically modulable at higher frequencies.

If I use a hotter source, how much more energy will I get from it?

The question above is a common one. Just how much additional energy do you get when you raise the temperature of an IR emitter?

To answer this, we have calculated the RATIO of the power (spectral radiance, watts per unit area per steradian) of a 1000C (1273K) blackbody to the power of a 750C (1023K) blackbody. The result is charted below:

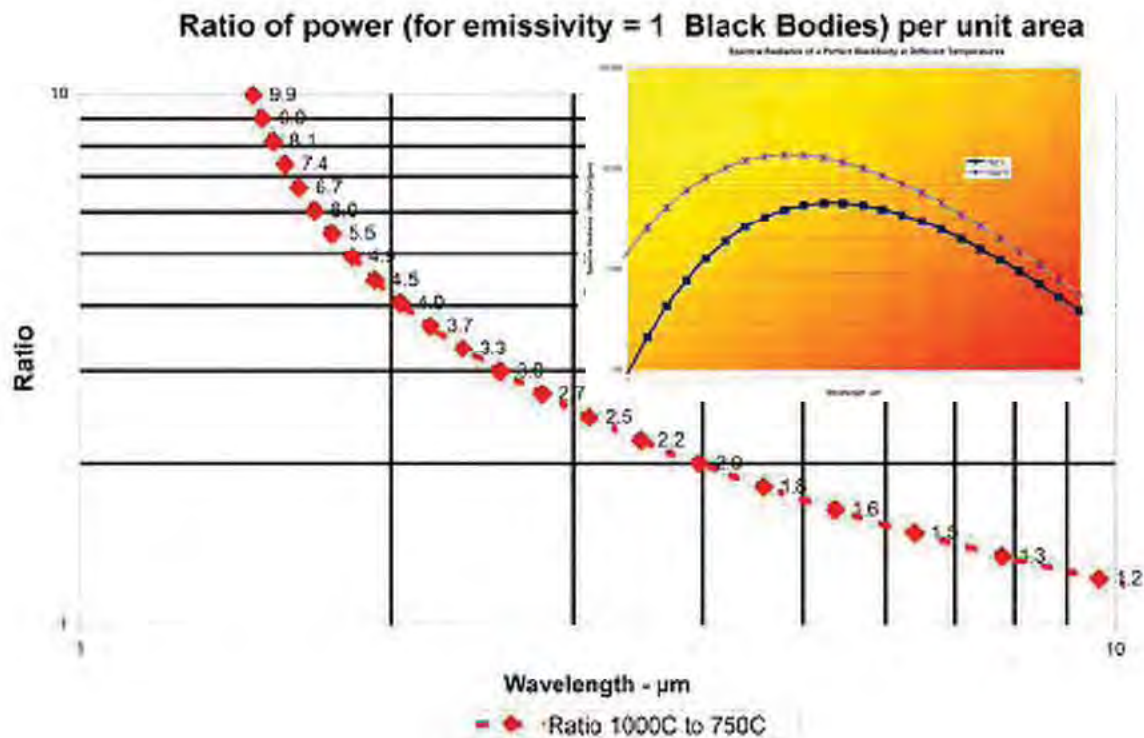

We find that at 2 microns one gets about 4 times more power, but this falls to 2 times more at 4 microns and only 1.5 times more at 6 microns.

The bottom line: turning up the heat may get you less than you hoped for.