

# Special UV-Index Sensor “ERYCA”

Read important application notes on page 5 ff.

---



## Features of the ERYCA special UV-Index Sensor

The UVI Sensor ERYCA is a further development of our product EryF. With an additional filter the accordance with the erythema action curve of the human skin had been further improved. The ERYCA is designed for use as a erythema sensor according to ISO 17166 CIE S 007/E (2000) – DIN 5050. It is optimally suited to feature high quality instruments for exact measurements of the UV Index. Overview on the advantages:

- **UVI precision is possible up to  $\pm \frac{1}{2}$  UVI**
- **perfectly suited for high precision low cost sun UV dosimetry**
- **the Sensor's current is directly proportional to the UV-Index**
- **also suited for sun tanning bank dosimetry**
- Based on approved EryF technology
- Schottky-type TiO<sub>2</sub> photodiode
- Intrinsic visible blindness due to wide-bandgap semiconductor material
- large photoactive area
- designed to operate in photovoltaic mode
- hermetically sealed metal TO18 housing and UV-glass window

## Maximum Ratings

| Parameter                        | Symbol     | Value       | Unit |
|----------------------------------|------------|-------------|------|
| Operating temperature range      | $T_{opt}$  | -20 ... +80 | °C   |
| Reverse voltage                  | $V_{Rmax}$ | 3           | V    |
| Forward current                  | $I_{Fmax}$ | 1           | mA   |
| Total power dissipation at 25 °C | $P_{tot}$  | 1           | mW   |

## General Characteristics

( $T_a = 25\text{ °C}$ )

| Parameter   | Symbol   | Value     | Unit            |
|---|----------|-----------|-----------------|
| Active area   | A        | 4,18      | mm <sup>2</sup> |
| Active area dimensions  | L x W    | 2.2 x 1.9 | mm <sup>2</sup> |
| Max. viewing angle  | $\alpha$ | 70        | degree          |
| Shunt resistance (dark)   | $R_s$    | 300       | M $\Omega$      |
| Dark current at 10mV reverse bias   | $I_d$    | 30        | pA              |
| Open circuit voltage (200 $\mu$ W/cm <sup>2</sup> , $\lambda=300$ nm)       | $V_0$    | >250      | mV              |
| min. Short circuit current (200 $\mu$ W/cm <sup>2</sup> , $\lambda=300$ nm) | $I_0$    | 160       | nA              |
| Breakdown voltage (dark)  | $V_{BR}$ | > 3       | V               |

## Spectral Characteristics

( $T_a = 25\text{ °C}$ )

| Parameter   | Symbol                              | garanteed Value | Unit               |
|---|-------------------------------------|-----------------|--------------------|
| min. spectral sensitivity at peak                           | $S_{\max}$                          | 19              | $\text{mA W}^{-1}$ |
| Wavelength of peak spectral sensitivity                     | $\lambda_{S_{\max}}$                | 300             | nm                 |
| Range of spectral sensitivity<br>( $S=0.1 \cdot S_{\max}$ ) | -                                   | 215 - 325       | nm                 |
| Visible blindness   | $\frac{S_{\max}}{S_{400\text{nm}}}$ | 100000          |                    |

## Spectral Response

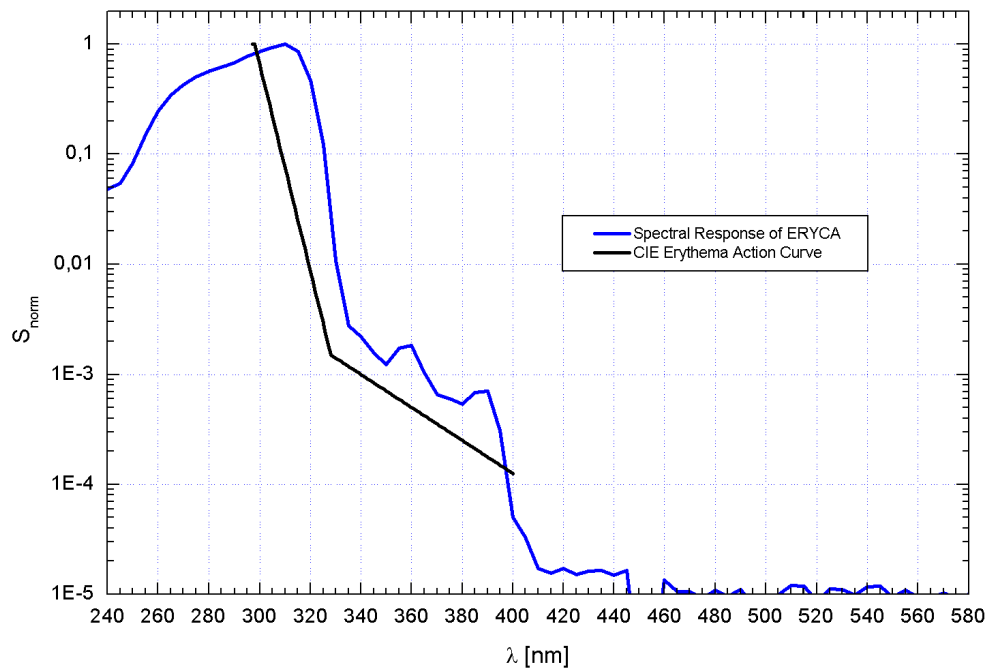

# Special UV-Index Sensor “ERYCA”

Read important application notes on page 5 ff.

---

## Pin Layout

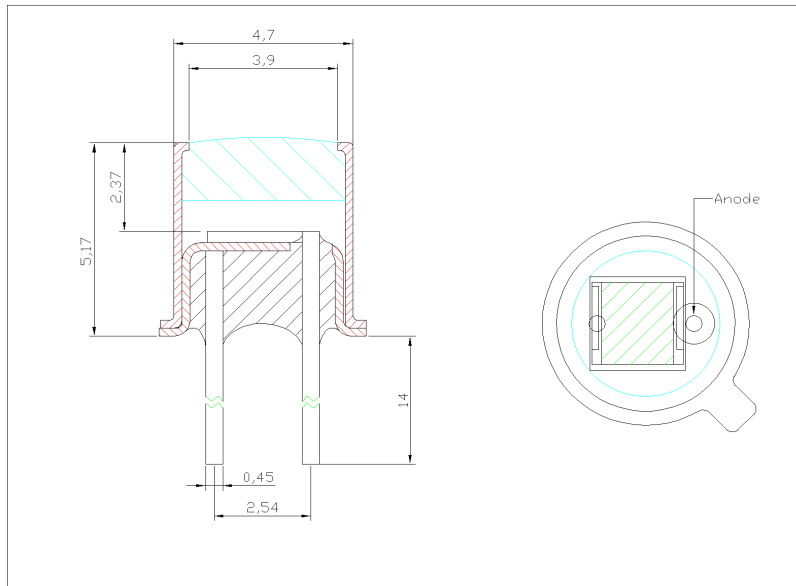

## Application notes

Our polycrystalline UV photodiodes are designed for **photovoltaic operation**. This operation mode is necessary to minimize the dark current of large area photo detectors which otherwise needs to be considered in the commonly used photoconductive mode.

First we want to show the implementation of photovoltaic operation with **commercially available photodiode (current) amplifiers**.

Many amplifier devices provide an adjustable bias voltage. This has to be switched off or trimmed to well below 0.1 V in order to ensure photovoltaic operation. In this case the connection of our photodiodes to such devices is rather simple, see figure 1.

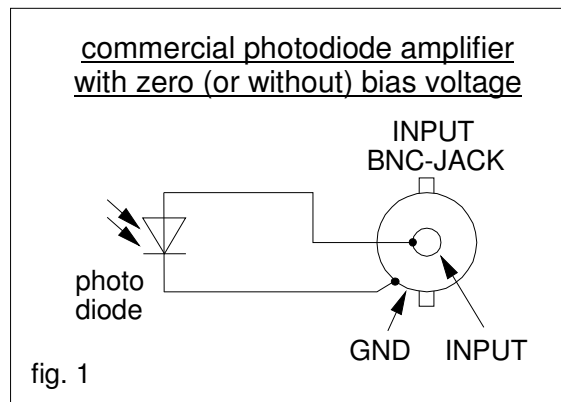

Some amplifiers only have a fixed bias voltage or the bias cannot be trimmed to near zero. In this case it is required to draw the ground level (which is not available on the input jack) from other sources, e.g. the output jack, special connectors or even from the housing. Please refer to the amplifier’s manual and figure 2.

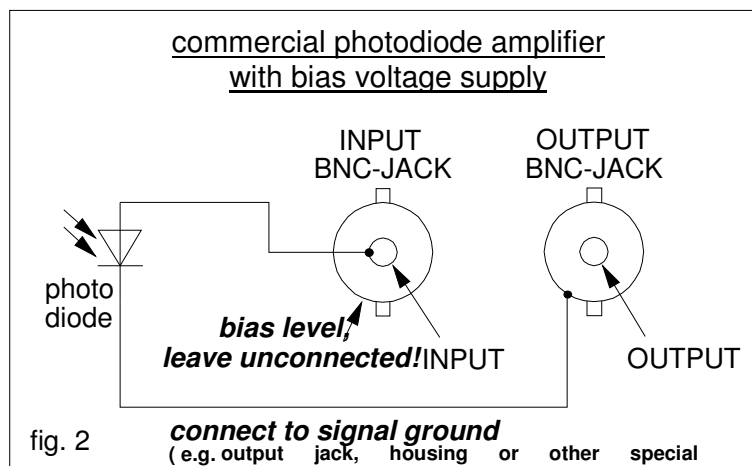

## Design of custom photodiode amplifiers

This complex topic strongly depends on your specific application. We provide flexible “ready to use” amplifier boards, consultation, development support as well as engineering solutions.

Nevertheless, we offer some examples, references for further reading and keywords for your convenience.

- Use amplifier chips with low input offset voltages and currents. Examples:  
high end: OPA128 (Texas instruments, Burr Brown)  
medium: TLV277x, TLC227x (Texas Instruments)  
low end: TL07x, TL08x (Texas instruments)
- Use transimpedance setup with feedback resistors not above 10 M $\Omega$  and without bias voltage. The figure below shows the basic schematic, however, all textbooks on basics of electronics cover plenty of details.  
Please also refer to the application note “*DESIGNING PHOTODIODE AMPLIFIER CIRCUITS WITH OPA128*”, (Texas Instruments, Burr Brown).  
If amplification above 10<sup>7</sup> V/A is required two stage amplifiers perform better.

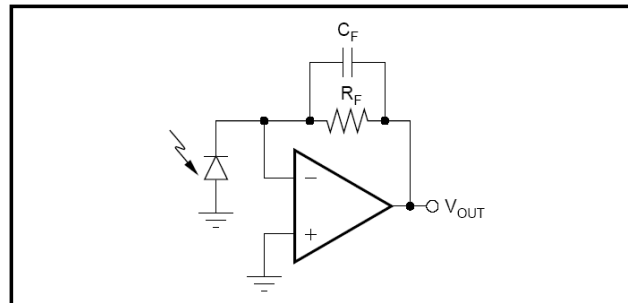

- For stability reasons apply a feedback capacitor parallel  $C_F$  to the feedback resistor  $R_F$ . Value depends on various parameters.  
Please also refer to the application note “*COMPENSATE TRANSIMPEDANCE AMPLIFIERS INTUITIVELY*”, (Texas Instruments, Burr Brown).  
Hint: Use 10 nF with OPA128 and 2 nF with TL07x, higher values minimize the noise dependence but also the bandwidth.
- Always use proper shielding, even on PCB: guard layers and wires are strongly recommended; reduce distances between sensor and amplifier chip; prevent ground loops.
- For general understanding of operational amplifier properties refer to the white paper (SLOA011) “*Understanding Operational Amplifier Specifications*” from Texas Instruments.

For further information, please feel free to contact us. All references can be found on the Texas Instruments website [www.ti.com](http://www.ti.com). Given products and information are to be considered as examples only. No guarantee is given for completeness or correctness. We take no responsibility for damages caused by using this information.