

id201

Single out your photons !

Single Photon Detector Module for the Near Infrared

RS-232 interface !

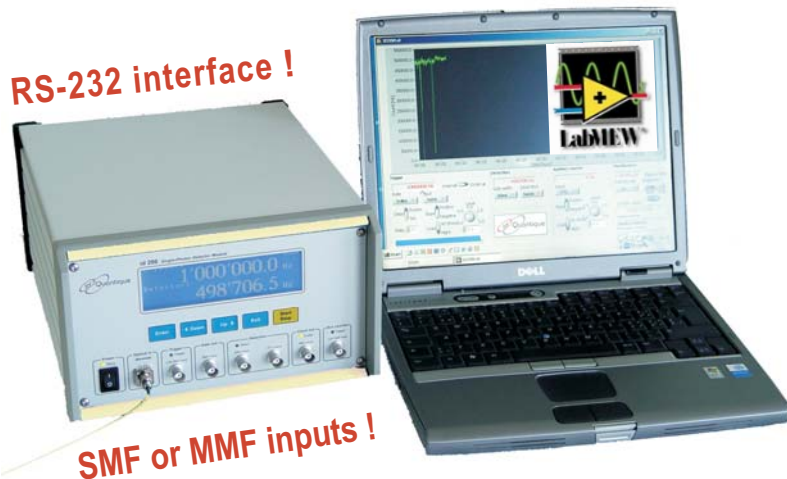

SMF or MMF inputs !

Detection probability
up to 25% !

New

custom application-oriented
modules upon request

Performance, versatility and ease of use - the hallmarks of id Quantique's newest photon counters

A complete system for your photon counting needs

Counting photons used to require a large number of instruments, such as delay and pulse generators, a counter, an avalanche photodiode and a cooling apparatus. The id201 does it all in a compact and transportable case. Get rid of your messy cables and bulky set-up arrangements and leave your tools in the drawer.

With the id201, focus on what you do best, world-class research.

Besides counting photons, the id201 offers truly invaluable functionalities:

- internal and auxiliary counters
- graphical display
- clock output, gate output
- NIM and TTL detector output signals
- RS-232 interface
- SMF or MMF fiber input

The most versatile photon counter

Building on the success of the id200, id Quantique's id201 is now offering new functionalities, such as adjustable detection probability and gate width. The id201 is by far the most versatile photon counter on the market.

Adjustable photon detection probability:

- 10 %, 15%, 20%, 25% and user-defined

Large range of trigger options:

- internal trigger: 1 kHz, 10kHz, 100kHz, 1 MHz
- external trigger: up to 8 MHz

Adjustable gate width:

- 2.5 ns, 5 ns, 20ns, 50ns, 100ns and user-defined

Adjustable dead time:

- 0 μ s, 1 μ s, 2 μ s, 5 μ s, 10 μ s, 20 μ s, 40 μ s, 60 μ s, 80 μ s, 100 μ s

Tunable delay:

- 0 to 25 ns

Ease of use and connectivity

The id201 offers a well-thought design with intuitive menus and an ergonomic display. All parameters can be adjusted via the graphical interface.

The id201 connects easily to PCs via an optional serial interface. A Labview Virtual Instrument is provided to remotely control the id201 in no time. The user can also control and read from the unit using a set of commands, in the programming language of his choice (e.g. Visual Basic, C or C++).

Proven reliability

The id201 is the most reliable photon counter on the market. It is built on the same platform as its predecessor, the id200, which has been used by researchers around the globe since first launched in early 2002. The photodiode at the heart of the id201 meets the most stringent reliability requirements (Telcordia GR-468-CORE).

Ordering information

id201-XXX-YYY Stand-alone detector module.

Please insert optical input code: XXX = SMF for Singlemode fiber input (SMF28)
XXX = MMF for Multimode fiber input (50/125 μ m)

Please insert dark count rate code: YYY = STD for Standard noise level
YYY = ULN for Ultra-Low Noise grade

id201-XXX-RS-YYY Stand-alone detector module with RS-232 computer interface for data acquisition.

Software and Programming Guide with Labview and C++ application examples are provided.

For further information on this or other products, please contact *id Quantique* by phone: +41 (0)22 301 83 71 or email: sales@idquantique.com.

Applications

Quantum Optics, Quantum Cryptography
Fiber optic characterization
Single photon source characterization
Spectroscopy
Eye-safe laser ranging (lidar)
Failure analysis of electronic circuits

id201

Single out your photons !

Block Diagram

The id201 is a complete photon counting system based on a cooled InGaAs/InP avalanche photodiode (APD) operating in Geiger mode. The operation temperature is set to -50°C to optimise the signal-to-noise performance. A temperature variation of less than 0.1°C is achieved through a thermoelectric cooler controlled by a PID regulator. The APD is operated in the so-called gated mode.

The id201 offers advanced functionalities, including:

A trigger unit providing the timing signal for the gate generation. The user can choose from external or internal trigger sources:

- The external trigger source can have NIM, TTL and a Var input types. The Var input type lets the user select three parameters: level, slope, load. The id201 accepts external trigger frequencies up to 8 MHz.
- An internal trigger source is also available. Trigger frequencies of 1 kHz, 10 kHz, 100 kHz and 1 MHz can be selected. The trigger signal is also available on a front panel connector for the synchronization of other devices (e.g. pulsed laser source, such as the id300).

A delay function, providing a delay between the trigger and the gate signals. This allows the user to scan the gate and synchronize the gate and the optical signals. Coarse synchronization should be done using cables and optical fibers, while fine adjustment can be obtained with the internal adjustable delay line. The delay can be adjusted from 0 to 25 ns in 100 ps increments.

A gate generator unit and a pulser unit produce a gate with the appropriate duration and amplitude. A variable deadtime can be selected to suppress afterpulse occurrences. The following parameters can be selected using an intuitive graphical user interface:

Dead time. At high trigger frequencies, afterpulsing may significantly deteriorate the performance. To suppress detrimental afterpulsing effects, the id201 allows one to set a dead time after a detection. The dead time duration can be chosen between $0\mu\text{s}$, $1\mu\text{s}$, $2\mu\text{s}$, $5\mu\text{s}$, $10\mu\text{s}$, $20\mu\text{s}$, $40\mu\text{s}$, $60\mu\text{s}$, $80\mu\text{s}$ or $100\mu\text{s}$. When this mode is enabled, the module will ignore trigger signals during a time equal to the deadtime after each registered avalanche event. The unit displays the actual trigger rate.

Gate width. Five different values of the gate can be set: 2.5 ns, 5 ns, 20 ns, 50 ns or 100 ns. A user-defined gate duration can also be entered. Gate widths of 2.5 ns and 5 ns result in an effective gate of typically 500 ps and 1.5 ns. These short gates provide a very low noise level for applications where the arrival time of the photon is known with high accuracy.

Photon detection probability at 1550 nm that can be chosen between 10%, 15%, 20% and 25%, independently of the gate width and trigger frequency. A user-defined detection probability can also be entered. Large detection probability levels allow one to obtain outstanding timing resolution.

An internal counter, whose result is displayed on the front panel to monitor the detection and the trigger signals. For each detection, the module also produces electronic pulses (NIM and TTL) available on front panel connectors. These pulses can, for example, be registered by an external counter or sent to a processing unit, such as a time-to-amplitude converter.

An auxiliary counter, which offers the possibility to count external signals. The result of the counter can then be displayed on the LCD screen.

The electronic circuit of the id201 has been designed to reach outstanding timing resolution of less than 300 ps at 25% detection probability.

All the user-adjustable parameters can be easily entered from the front panel or, when this option is selected, from a computer connected to the RS232 port. The graphical user interface offers several display modes: 1) display the internal and auxiliary counters as frequencies, 2) display the number of counts of the internal and auxiliary counters, 3) display the trigger rate and the internal counter as frequencies, 4) display the ratio of the internal counter over the trigger counter as well as the auxiliary counter frequency, and 5) display all the important detector parameters.

For demanding photon-counting applications, where every source of stray light can induce noise, it is possible to dim the id201 front panel back illumination and LED's indicators. This option is useful when visible spectrum photon counting detectors are used in combination with the id201.

Definitions:

- Detection probability:** Probability that a photon arriving on the diode within a gate will give an output pulse.
Timing resolution: Spread of the temporal position of the detector output leading edge caused by statistical temporal fluctuations.
Dark counts: Unwanted counts caused by thermal and/or tunneling generation effects produced in absence of light.
Afterpulsing: Spurious counts caused by carriers trapped in deep levels introduced by impurities and crystal defects and released within a subsequent gate.

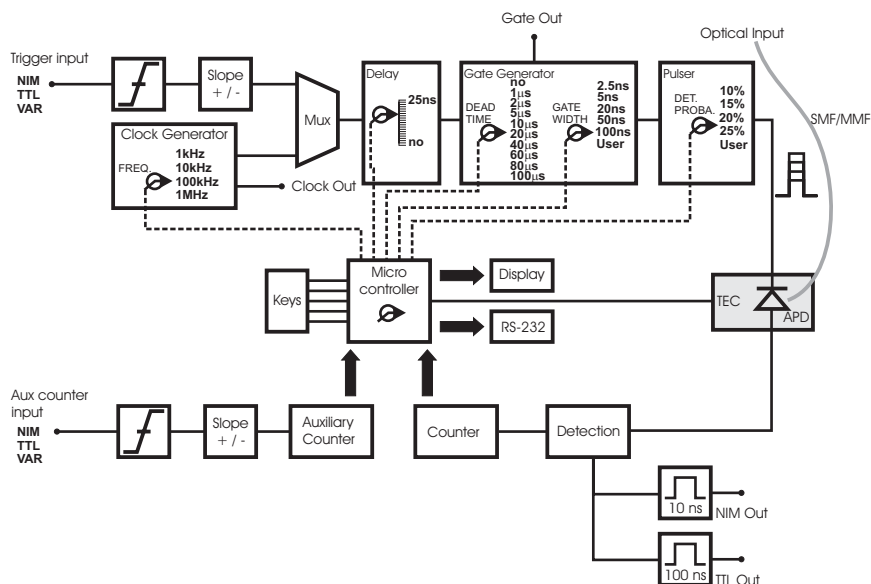

id201

Single out your photons !

General Specifications				
Features	Minimum	Typical	Maximum	Units
Wavelength range 1		900-1700		nm
Fiber type		SMF or MMF		
Single photon detection probability (SPDE) 1 1		10, 15, 20, 25, user-defined		%
Timing jitter at 10% SPDE 2			600ps	ps
Timing jitter at 25% SPDE 2			300ps	ps
Maximum external trigger frequency 2		8		MHz
Max trigger frequency (afterpulse probability < 1%)		100		kHz
Gate duration	2.5, 5, 20, 50, 100, user-defined			ns
Adjustable delay range 4		25		ns
Adjustable delay step		0.1		ns
Adjustable deadtime 3	0, 1, 2, 5, 10, 20, 40, 60, 80, 100			μs
Internal trigger generator		1, 10, 100, 1000		kHz
Trigger and aux counter inputs		NIM, TTL, Var		
Clock & Gate Outputs 4		NIM		
Detection Output 5		NIM (10ns width), TTL (100ns width)		
Operating temperature		+10 to +30		°C
Dimension L x W x H		300 x 250 x 150		mm
Weight		4000		g
Optical connector		FC/PC		
Electronic connectors		BNC		
Power supply		110 - 230		VAC
Cooling time		5		min

Dark count rate: id Quantique modules are available in two grades: **Standard** and **Ultra-Low Noise**, depending on dark count rate specifications. The id201-CUSTOM is a special application-oriented module.

3	Fiber Type	Dark Noise Grade	Noise /ns of gate at SPDE=10%	Noise /ns of gate at SPDE=25%
id201-SMF-STD	single mode	standard	< 1.0 x 10 ⁻⁴	< 4.0 x 10 ⁻⁴
id201-SMF-ULN		ultra-low noise	< 8.0 x 10 ⁻⁵	< 6.0 x 10 ⁻⁵
id201-MMF-STD	multimode	standard	< 2.0 x 10 ⁻⁴	< 8.0 x 10 ⁻⁴
id201-MMF-ULN		ultra-low noise	< 1.5 x 10 ⁻⁵	< 1.2 x 10 ⁻⁴

id201-CUSTOM ★ *If the STD and ULN grades do not fit your application, please contact us to discuss your needs. We'll do our best to design an application-oriented module.*

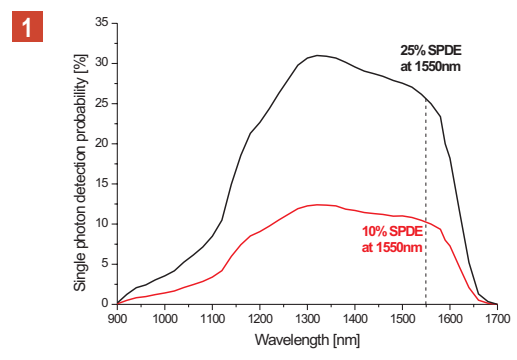

Single photon detection probability versus wavelength. (10% level at 1550nm in red, 25% level at 1550nm in dark).

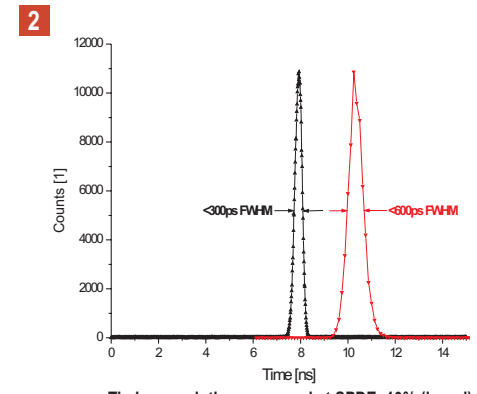

Timing resolution measured at SPDE=10% (in red) and SPDE=25% (in black).

Supplied Accessories

- Fiber optic connector reel cleaner
- 1m patchcord

- 1** Calibrated at the reference wavelength of 1.55 μm.
- 2** Delay: bypass, gate: 2.5ns and 5ns.
- 3** Calibrated at the 2.5ns gate, 100kHz trigger frequency and no dead time.

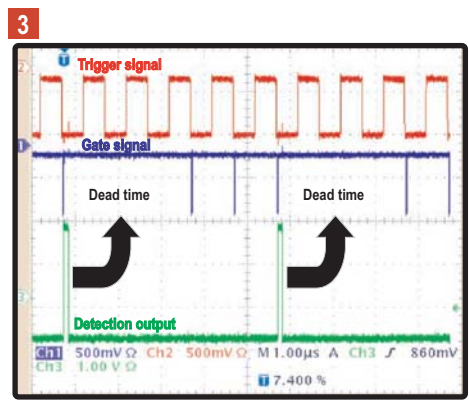

Oscilloscope acquisition showing the dead time introduced on the gate signal.
Set-up: 1MHz trigger signal, 20ns gate width, 2μs dead time.

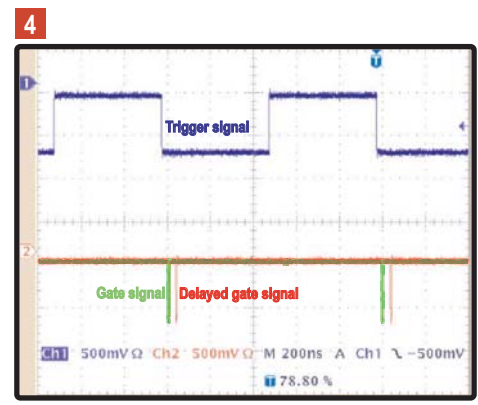

Oscilloscope acquisition showing NIM trigger and gate signals. The gate signal without delay is shown in green; the gate signal with a 25ns delay is shown in red.
Set-up: 1MHz trigger signal, 5ns gate width, no / 25ns delay.

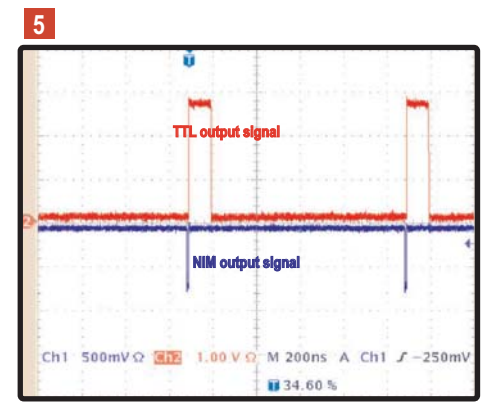

Oscilloscope acquisition showing the NIM and TTL outputs.

id201

Single out your photons !

Instrument Connectivity - Optional RS-232 Computer Interface

Connect the id201 to a computer via a serial link and start using the unit remotely in no time. Programming and accessing your id201 using its RS-232 interface is simple and allows the implementation of complex functions. For example, a complete gate scanning can be performed by automatically changing the delay.

There are several ways to control the instrument:

A Labview Virtual Instrument (VI) is provided that lets you control the id201 via a graphical interface, as shown in the picture on the right. This VI allows you to set all the parameters of the id 201, and displays the number of counts recorded as a function of time. This VI can easily be modified and integrated within the custom VI of your measurement setup.

The user can also control the unit and read test results using a set of commands, in the programming language of his choice (e.g. Visual Basic, C or C++). A complete Programming Guide is provided with the unit, including examples of C++ programs.

Labview Virtual Instrument provided !

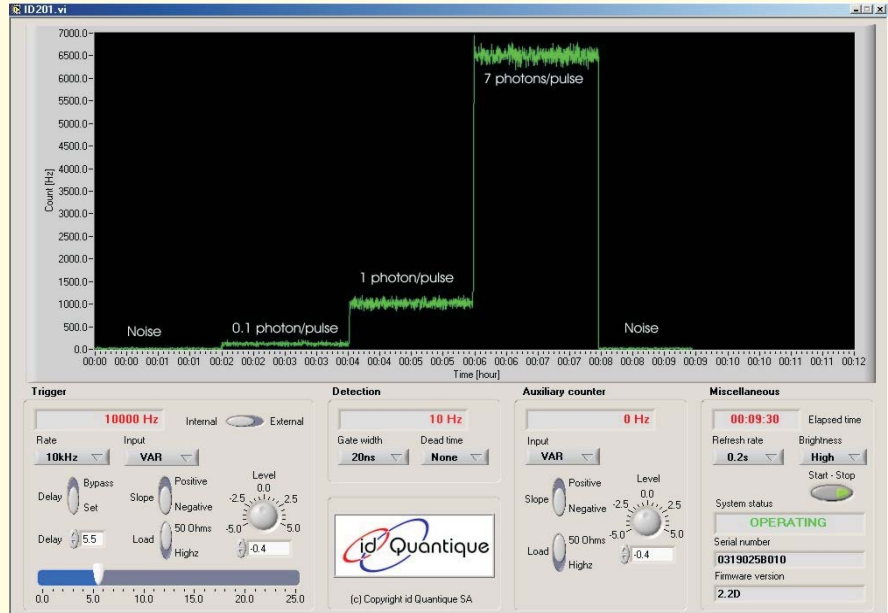

id300 - Short-Pulse Laser Source

In your experiment you may need to generate short laser pulses. id Quantique's id300 Short-Pulse Laser Source is the ideal companion to the id201. The laser source can be directly triggered by the id201's internal trigger. When the output power is properly reduced with a calibrated optical attenuator, the id300 ideally simulates a single photon source.

Key features of the id300:

- typical pulse duration of 300 ps
- repetition rate from DC to 500 MHz
- wavelength of 1310 nm or 1550 nm
- external trigger



Other Products (please visit our website <http://www.idquantique.com>)

id100	Single photon counting module for the visible spectral range
id300	Short pulse laser source
id400	Single photon counting module for the 900-1150nm spectral range
Quantis	Quantum Random Number Generator
Clavis ²	Quantum Key Distribution System for R&D
Cerberis	Layer 2 encryptor with Quantum Key Distribution
Centauris	Layer 2 encryptor

Disclaimer

The information and specification set forth in this document are subject to change at any time by id Quantique without prior notice.

Copyright© 2002-2009 id Quantique SA.
All rights reserved.