

Basic Information

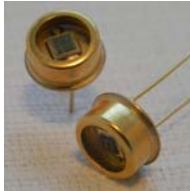

SiC UV Photodiode Selection Guide

That guide assists you selecting the right UV Silicon Carbide (SiC) based photodiode for your application. Basically this selection is between active area, spectral behaviour, packaging and additional special features. This first page is basic information and subsequent pages provide background knowledge and electronic circuit examples.

About the sglux Silicon Carbide (SiC) UV photodiodes

The offered UV photodiodes base on a Silicon Carbide detector chip. SiC provides the unique property of near-perfect visible blindness, low dark current, high speed and low noise. These features make SiC the best available material for visible blind semiconductor UV detectors. The SiC detectors can be continuously operated at up to 120°C. All photodiodes are available with HT (high temperature) feature that allows operation up to 170°C (338°F). The temperature coefficient of signal is <0.1%/K only. Because of the low noise, (dark current, in the sub-fA range), very low optical radiation intensities can be measured reliably. As the photocurrent level of UV photodiodes is low (only some nA or less) the photodiode amplifier circuit needs special care. If you are not familiar with low current amplification please feel free to study the related chapter of this guide or have a look at the amplifier and controller modules we produce or consider to apply a sglux TOCON (hybrid sensors with included pre-amplifier).

Nomenclature

The UV photodiodes follow the below nomenclature. All part numbers start with SG01 indicating a sglux SiC UV photodiode. The following table shows the selection opportunities and the prices:

SG01[*chip area*] - [*spectral response*] [*packaging*] [*special*]

[<i>chip area</i>] in mm ²		[<i>spectral response</i>]		[<i>packaging</i>]		[<i>special</i>]	
[]	value	[]	value	[]	value	[]	value
S	0.04	-	Broad-Band	18	TO18	-	nothing special
M	0.20	A	UVA	18ISO90	TO18 ISO	HT	T = 170°C
L	1.00	B	UVB	18S	TO18 short	Lens	concentr. Lens
XL	4.00	C	UVC	5	TO5	MEGA	attenuated
		E	UV-Index	5ISO90	TO5 ISO	-HT	0.5 W/cm ²
						GIGA	attenuated
						-HT	7 W/cm ²

Further information

- use our interactive SiC UV photodiode finder → www.boselec.com
- call us (617) 5663821 or send us an email → uv@boselec.com
- study the background information shown at the following pages of this guide

Background Information

Table of Contents

1.0 Selection of the Chip active area (photocurrent limits)	page 2
1.1 Problems with current too low (circuit linearity & temperature issues)	page 3
1.2 Problems with current too high (saturation)	page 5
1.3 Calculation of the relation between UV radiation and photocurrent	page 5
2.0 Selection of the Spectral Response	page 7
2.1 Unfiltered SiC	page 7
2.2 Filtered SiC	page 8
3.0 Packaging features	page 9
3.1 Overview	page 9
3.2 Drawings	page 10
4.0 Special features	page 12
Appendix A Photodiode Amplification Notes	page 13
Appendix B Accessoires	page 13
Appendix C Photodiode Calibration Service	page 13

1.0 Selection of the Chip active area (photocurrent limits)

The chip active area determines how many light quantum, (photons), can be collected by a photodetector. Semiconductor detectors, such as SiC UV photodiodes, convert the photons into an electrical current, the *photocurrent I*. This photocurrent rises linearly with the chip active area. sglux currently offers four different area sizes

$$A_1 = 0.04 \text{ mm}^2 \text{ (S-type)}$$

$$A_2 = 0.20 \text{ mm}^2 \text{ (M-type)}$$

$$A_3 = 1.00 \text{ mm}^2 \text{ (L-type)}$$

$$A_4 = 4.00 \text{ mm}^2 \text{ (XL-type)}$$

As the detector price rises with increasing active area, (see price information at p.1), the area selection basically is a compromise between costs and current.

If you know the minimum and maximum irradiance you like to measure with the UV photodiode the following simplified formula (1) shows a rough estimation of the photocurrent *I* given a particular chip active area A_{Chip} .

$$I = A_{\text{chip}} * E_{\lambda} * 1.000 \tag{1}$$

I is the photocurrent in nA, A_{chip} is the chip active area in mm^2 (enter values of 0.04 or 0.20 or 1 or 4) and E_λ is the spectral irradiance of the UV light source you like to measure in $mWcm^{-2}nm^{-1}$. You may find more information about photocurrent calculation in chapter 1.3 (Calculation of the relation between UV radiation and photocurrent), p. 5.

If you do not know the irradiance coming from your UV light source chapter 1. section 1.3 gives some examples of common UV sources.

The minimum current (photodiode output at lowest irradiance to be measured) should not fall below 500pA. The maximum current should not exceed 2 μ A and must not exceed 40 μ A if the component's diode properties are to be maintained. Please refer to a detailed discussion on suitable minimum and maximum currents in the following chapters 1. section 1.1 (Problems with current too low) and 1. section 1.2 (Problems with current too high). These chapters assume a certain basic knowledge in photodiode amplifier circuits. If you are not familiar with circuits please see Appendix A (Photodiode Amplification Notes) at page 10.

1.1 Problems current with too low

If the current is too low, one or more of the following problems ($P_1 - P_4$) may affect the measurement:

- $P_1 \rightarrow$ The measurement signal comes too close to the UV photodiode dark current
- $P_2 \rightarrow$ High resistance feedback resistors (R_f) must be used which causes temperature drift and non linearity problems
- $P_3 \rightarrow$ Speed problems
- $P_4 \rightarrow$ Risk of electromagnetic interferences

Using SiC, **P_1 can be neglected** due to the extremely low dark current of the sglux 4H SiC UV photodiodes of only some fA. **P_2 (temperature drift and non linearity)** becomes essential from values $R_f > 10 G\Omega$. Therefore, the photocurrent I should be strong enough to allow R_f values of $\leq 10 G\Omega$. The relation between I and R_f is given by Ohm's law:

$$I = U_{supply} / R_f \quad (2)$$

where U_{supply} is the supply voltage of the used transimpedance amplifier. A typical value is 5.00 V. Formula (2) calculates:

$$I_{min} = 5.00V / 10 G\Omega = 500pA \quad (3)$$

If a higher speed measurement is needed **P₃ (speed problems)** could become an issue. As the SiC UV photodiode's detection speed is extremely high (in nanoseconds only) the amplifier speed (rise time) always determines the circuit's speed. The amplifier rise time is calculated with the following formula:

$$\tau = R_f * C_f \quad (4)$$

where C_f is the feedback capacitor value which should not be lower than 0.1 nF. A lower C_f risks hitting the circuit's resonance. Using a $C_f = 0.1$ nF and a $R_f = 10$ G Ω the rise time is calculated as follows:

$$\tau = 10 \text{ G}\Omega * 0.1 \text{ nF} = 1 \text{ second} \quad (5)$$

Formula (5) shows that using a $R_f = 10$ G Ω the circuit becomes very slow. If a higher speed is needed the photocurrent I must be increased to allow a decrease in the R_f value. This can be done by increasing the UV radiation or, if that is not feasible, by increasing the chip active area.

The last problem (**P₄**) that can be caused with too low photocurrent (= due to too small an active area) is complications from electromagnetic interferences. This is a general issue. Decreasing photocurrents call for increasing shielding efforts which then increases the system price of the product. If the radiation (and thus the current) is low one should consider using a sglux TOCON pre-amplified hybrid UV sensor.

Conclusion of needed minimum photocurrent I_{min}

To achieve a stable temperature and linear photodiode-amplifier system the lowest measurement current I_{min} should be higher than 500pA. If a high speed measuring circuit is needed I_{min} is calculated by the following formula:

$$I_{min} = U_{supply} * C_f * \tau^{-1} \quad (6)$$

With $U_{supply} = 5.00$ V (typical value), $C_f = 0.1$ nF (recommended value) and $R_f = 10$ G Ω (lowest recommended value) the formula reduces to:

$$I_{min} = 500 * \tau^{-1} \quad (7)$$

where I_{min} results in nanoamperes (nA) and τ must be in milliseconds.

In general, given these reasons, a decreasing photocurrent needs a more advanced amplifier design and better shielding. If you are not familiar with low current circuit development you should consider selecting a higher current (and thus larger active area) photodiode even if the price of a photodiode is higher. This strategy will provide conservative results and the initial increased financial cost will save you money in the long run.

1.2 Problems with current too high (saturation)

In the previous pages we discussed the calculation of a minimum recommended photodiode current. It also should be mentioned that aside from the photocurrent being too low too high of a current may cause problems as well due to saturation effects. The saturation current I_{sat} of a photodiode is the current limit from which the output of a photodiode turns to arbitrary values. It is determined by the photodiode's open circuit voltage V_{OC} and its serial resistance R_S following the formula below:

$$I_{sat} = V_{OC} / R_S \quad (8)$$

A typical value (SiC photodiode) for V_{OC} is 2.0V and for $R_S = 50k\Omega$. The calculation is a follows:

$$I_{sat} = 2.0 \text{ V} / (50 * 10^3) \Omega = 4 * 10^{-5} \text{ A} = 40\mu\text{A}.$$

The needed minimum current (500 pA) is higher than the saturation current is higher by six orders of magnitude. Reaching the saturation limit of a SiC photodiode is therefore very unlikely.

However, one should consider that a SiC UV photodiode is a sensible instrument for measurement. Even if SiC UV photodiodes are the most stable and most linear UV photodiodes currently available, values that come close to the limit should be avoided. The majority of applications use a photocurrent range from 1nA to 2000nA. Thus, whenever possible, **the maximum current should not exceed 2000nA.**

1.3 Calculation of the relation between UV radiation and photocurrent

The photocurrent I is calculated by the following formula:

$$I = \int_{200\text{nm}}^{400\text{nm}} A_{chip} \cdot S_{chip}(\lambda) \cdot E_{source}(\lambda) d\lambda \quad (9)$$

where I is the photocurrent in A, A_{chip} is the chip active area in m^2 , S_{chip} is the chip's spectral sensitivity in AW^{-1} and E_{λ} is the spectral irradiance of the UV light source in $Wm^{-2}nm^{-1}$. Due to extreme visible and IR blindness the integral value from 400nm to ∞ can be neglected even if $E_{source}(\lambda)$ is very strong. To get a rough estimate of the photocurrent generated by a certain irradiance a simplification of (9) leads to (10). That simplification assumes that the chip's spectral sensitivity S and the UV source's irradiance E is a constant value and does not depend on wavelength. The calculation is:

$$I = A_{chip} * S_{chip} * E_{\lambda} * 10.000 \quad (10)$$

where I is the photocurrent in nA, A_{chip} is the chip active area in mm^2 , S_{chip} is the chip's spectral sensitivity in $AW^{-1}nm^{-1}$ and E_{λ} is the spectral irradiance of the UV light source in $mWcm^{-2}nm^{-1}$.

A typical value of S_{chip} is 0.1 A/W. For further refinement please refer to the spectral response graph of the UV photodiode you are interested in (see Datasheet) or have a look at chapter 2.0 (Selection of the Spectral Response, p. 7) of this guide.

If you know the theoretical spectral irradiance range, (minimal and maximal values), of the UV light source and you would like to measure you can easily estimate the photocurrent I by using formula (10) and hence select a chip active area (S-, M-, L- or XL-type) that guarantees that your minimum radiation generates a photocurrent of more than 500 pA and your maximum radiation generates a current of, if possible, less than 2000 nA.

The following table lists some common UV applications / light sources with their spectral irradiances at peak. Please note that some simplifications apply; thus the table gives a rough estimation of photocurrents for the different UV source types and different chip active areas.

UV source	Typ. peak E_λ	S-Type I	M-Type I	L-Type I	XL-Type I
lacquer hardening Fe doped Hg medium pressure lamp	10 W/cm ²	400 μ A 400 nA with attenuated „GIGA“ feature	2 mA	10 mA	40 mA
UV sterilisation low or medium pressure Hg lamp	10 mW/cm ²	400 nA	2 μ A	10 μ A	40 μ A
Industrial and R&D various sources	10 μ W/cm ² - 1 mW/cm ²	0.4 - 40 nA	2 – 200 nA	10 – 1000 nA	40 – 4000 nA
UV-Index Sun	10 μ W/cm ²	400 pA	2 nA	10 nA	40 nA
Burner flame detection gas or oil flame	10 nW/cm ²	400 fA	2 pA 100 pA with “LENS” feature	10 pA	40 pA

Comments:

lacquer hardening

all current values of the standard photodiodes are too high. For lacquer hardening lamp control a special „GIGA“ attenuated photodiode will be applied. Please refer to chapter 4.0. (Special features) for more information.

UV sterilisation

S-chip is best. M, L, XL chips would work but are not needed.

Industrial and R&D

All chips are suited. Speed is the main consideration when selecting a chip being mindful of linearity and temperature dependence values. Please contact us for further refinement.

UV-Index

S-Chips are too small for this application. All other chips can be applied. The reliability increases with increasing chip active area. Due to very low current the use of a TOCON (pre-amplified hybrid sensor) should be considered.

Burner flame detection

All chips are too small for this type of detection. A burner flame can be detected with the photodiode „SG10M-5Lens“. This sensor works with a concentrating lens. Please refer to chapter 4.0. (Special features), for more information. Another approach is to use a sglux TOCON_nano sensor with its included pre-amplifier. The TOCON_nano converts 0-10 nW/cm² radiation into a 0-5 V output voltage.

2.0 Selection of the Spectral Response

This chapter assists in the selection of a spectral response profile best suited for the measurement. All sglux 4H SiC UV photodiodes provide an extreme visible/IR blindness of more than ten orders of magnitude. That means that the UV photodiodes reliably only measure the UV part of a radiation spectrum (and not the visible and/or infrared part), even if visible light or infrared radiation is strongly present. This is a unique feature of the semiconductor material SiC. Currently no other material provides that extreme visible blindness.

2.1 Unfiltered SiC

The following graph shows the spectral curve of an unfiltered 4H SiC UV photodiode.

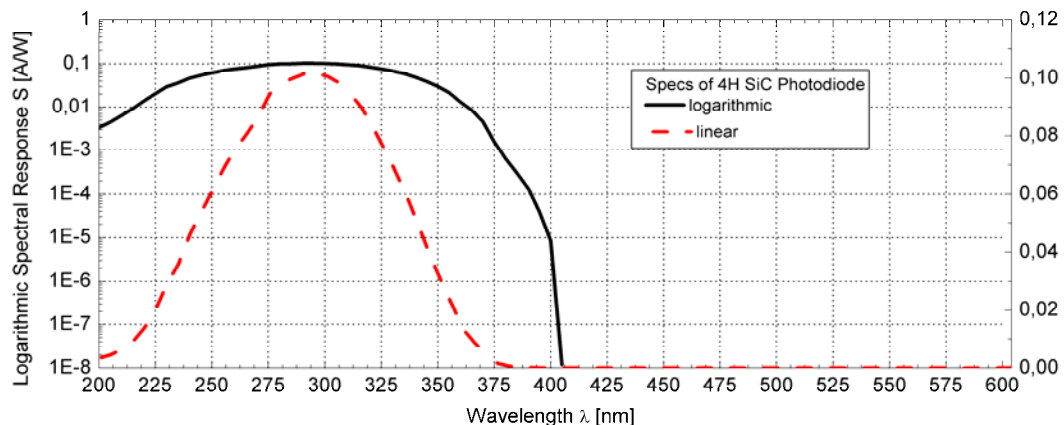

The curve's maximum is at approximately 300nm. The response falls down to 10% of maximum at 215nm, (UVC edge) and 365nm, (UVA edge). Unfiltered SiC can be used for any UV measurements where the whole UV band needs to be measured or a quasi monochromatic UV source (such as low pressure lamps) is controlled.

2.2 Filtered SiC

Some applications require measurement of one particular part of the UV radiation spectrum, and it is essential that other UV radiation parts do not contribute to the photodiode's current. This requirement usually arises from standards as DVGW W294/2006 or CIE078 etc. Other applications for filtered photodiodes are UVA-UVB-UVC selective sensor probes. sglux industrially produces four different filtered SiC UV photodiode types.

- UVA (max = 335nm)
- UVB (max = 280nm)
- UVC (max = 270nm)
- UV-Index (following CIE087 curve)

The following graph shows the four different spectra.

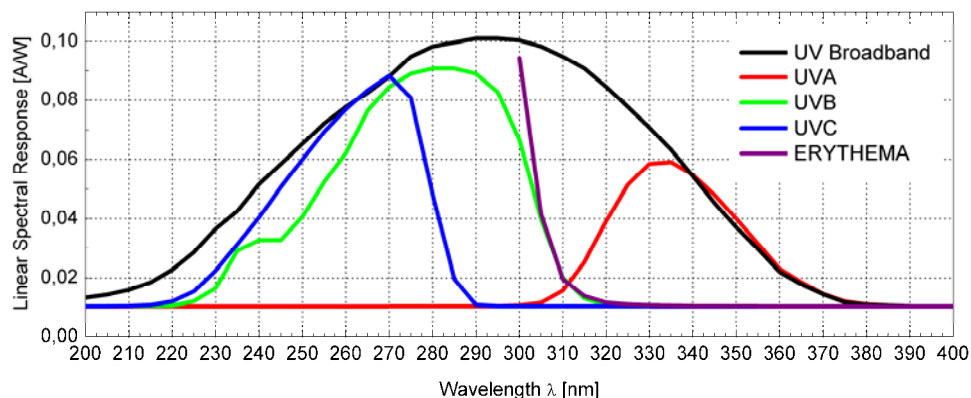

The graph assigns the filtered photodiode's spectral response to an individual wavelength. The following table extracts the most important specifications.

Filter type	Wavelength of max.	Sensitivity at max.	Wavelength 10% left side	Wavelength 10% right side	Visible Blindness
no filter (BBand)	300 nm	0.10 A/W	215 nm	365 nm	>10 ¹⁰
UVA	335 nm	0.06 A/W	310 nm	370 nm	>10 ¹⁰
UVB	280 nm	0.09 A/W	230 nm	315 nm	>10 ¹⁰
UVC	270 nm	0.10 A/W	230 nm	285 nm	>10 ¹⁰
ERYTHEMA	300 nm	0.90 A/W	–	310 nm	>10 ¹⁰

Other spectral specifications are available on request.





3.0 Packaging features

All sglux SiC UV photodiodes use a hermetically sealed melted window metal package. Each photodiode is gross and fine leak tested before sales. Two different sizes, (TO18 and TO5), with corresponding different heights and pin terminals are offered.

The reason for the different packaging types are technical in nature, (field of view, electrically floating housing, etc.) or just to allow the replacement of a previously applied photodiode by keeping the geometric parameters.

3.1 Overview

The below table illustrates the different packaging selection opportunities .

sample picture	selection code	description
	18	TO18 Ni plated housing, 5.6 mm diameter, 5.2 mm height two gold plated pins (Anode grounded and Cathode isolated).
	18ISO90	TO18 Ni plated housing, 5.6 mm diameter, 5.2 mm height three gold plated pins (Anode and Cathode isolated, additional third pin for optional grounding of the body).
	18S	TO18 Ni plated short housing, 5.6 mm diameter, 3.8 mm height two gold plated pins (Anode grounded and Cathode isolated). Not available with filters.
	5	TO5 Ni plated housing, 9.2 mm diameter, 4.3 mm height (unfiltered photodiodes), 6.6 mm height (filtered photodiodes), two gold plated pins (Anode grounded and Cathode isolated).
	5ISO90	TO5 Ni plated housing, 9.2 mm diameter, 4.3 mm height (unfiltered photodiodes), 6.6 mm height (filtered photodiodes), three gold plated pins (Anode and Cathode isolated, additional third pin for optional grounding of the body).

3.2 Drawings

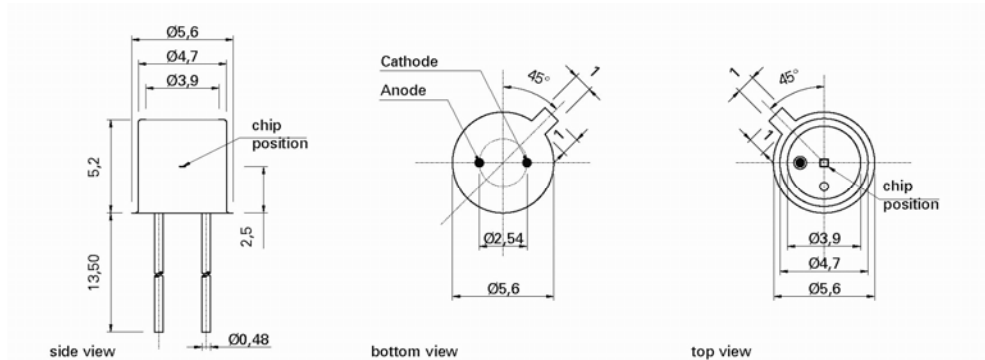

Selection code "18" → TO18 Ni plated housing, 5.6 mm diameter, 5.2 mm height two gold plated pins (Anode grounded and Cathode isolated).

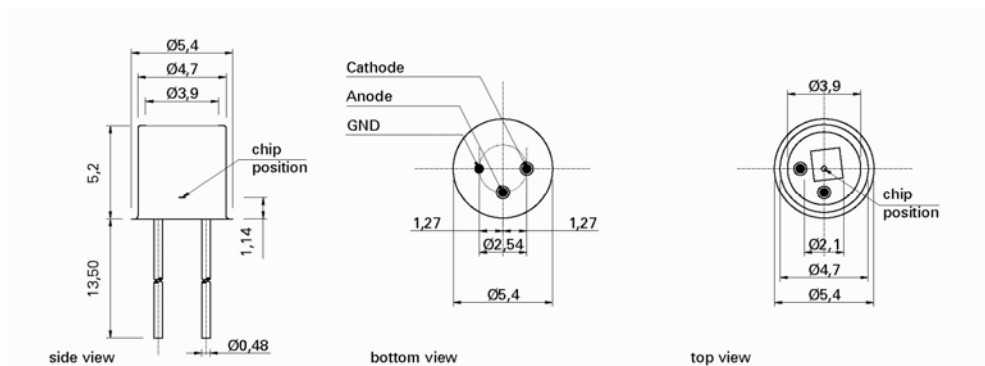

Selection code "18ISO90" → TO18 Ni plated housing, 5.6 mm diameter, 5.2 mm height three gold plated pins (Anode and Cathode isolated, additional third pin for optional grounding of the body).

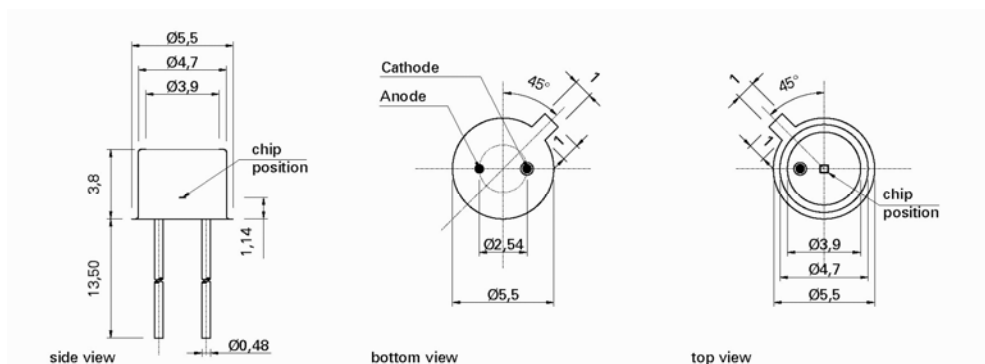

Selection code "18S" → TO18 Ni plated short housing, 5.6 mm diameter, 3.8 mm height two gold plated pins (Anode grounded and Cathode isolated). Not available with filters.

SiC UV Photodiode Selection Guide

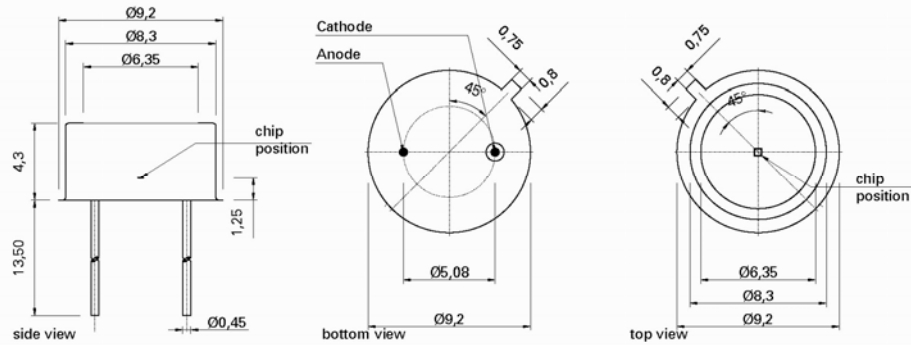

Selection Code "5" (photodiodes without filters) → TO5 Ni plated housing, 9.2 mm diameter, 4.3 mm height, two gold plated pins (Anode grounded and Cathode isolated).

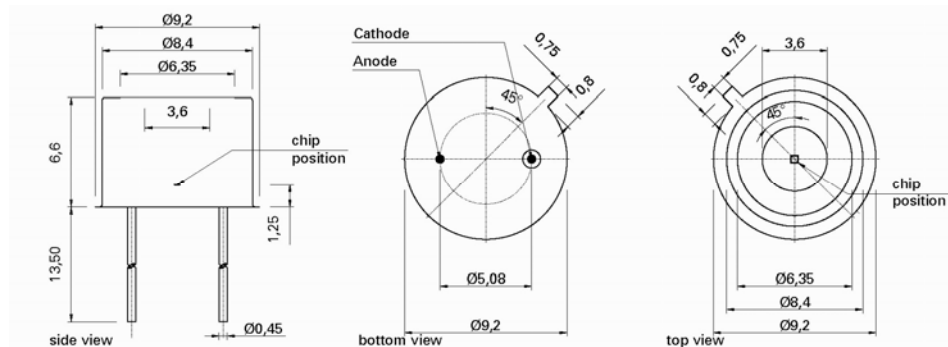

Selection Code "5" (photodiodes with filters) → TO5 Ni plated housing, 9.2 mm diameter, 6.6 mm height, two gold plated pins (Anode grounded and Cathode isolated).

4.0 Special features

Besides the three main selection criteria chip active area, spectral response and packaging details some special features can be added to the photodiode's properties. These special features are useful if the UV radiation is extremely high or low or if the working temperature is high. The below table shows the selectable special features.

selection code	description
HT	enhances the standard maximum operating temperature of $T = 120^{\circ}\text{C}$ (248°F) to $T = 170^{\circ}\text{C}$ (338°F) by using special packaging material.
Lens	 Concentrating Lens creating a virtual active area of 55 * real active area. This, approximately multiplies the current by factor 55 while using the same chip active area. A disadvantage is a strongly reduced field of view compared with the flat window type.
MEGA-HT	special attenuated photodiode for very strong UV radiation up to $500 \text{ mW}/\text{cm}^2$ to $T = 170^{\circ}\text{C}$ (338°F) maximum operating temperature
GIGA-HT	special attenuated photodiode for extreme UV radiation up to $7000 \text{ mW}/\text{cm}^2$ to $T = 170^{\circ}\text{C}$ (338°F) maximum operating temperature

Appendix A Photodiode Amplification Notes

For a correct reading of the photodiode the current (and not the voltage) must be analyzed. This requires a short circuiting of the photodiode. Usual approaches are using a Picoamperemeter such as Keithley 617 or a *transimpedance amplifier* circuit as shown below.

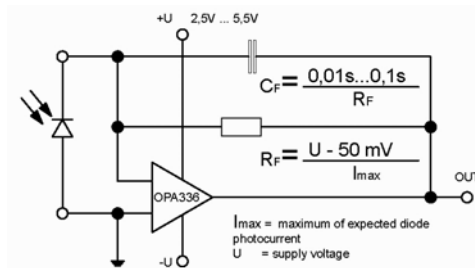

The adjacent design gives an example of a simple amplifier circuit. At the left side the photodiode is shown. The upper connection is the Cathode (isolated pin of the photodiode) and the lower connection is the Anode (usually grounded pin of the photodiode).

We recommend using a Texas Instruments OPA336 transimpedance amplifier.

The OPA336 is a low priced amplifier that is sufficient for the majority of applications.

Appendix B Accessoires

If you are not familiar with photodiode amplifier design or if you like to save time, the products on the list below may help you to get the best measurement information from your photodiode.

Internal & external Photodiode Amplifiers



- stable and reliable photodiode amplification
- TOCON-Series = photodiodes with integrated amplifier
- BOARD-Series = external photodiode amplifiers

UV probes with built in amplifier



- different housings e.g. with cosine response, water pressure proof or Sapphire windows
- different electronic outputs available (voltage, current, USB)

UV Intensity / Dose Monitor / Controller "SENSOR MONITOR"



- two channel photodiode or sensor input
- three user programmable relay outputs
- programmable display, USB/TTY/RS232 data transmission

Appendix C Photodiode Calibration Service



Some applications require **absolute measurements**: The photocurrent from the photodiode needs to be exactly assigned to the irradiance of the source to measure. This guide and the datasheet information will allow for a rough estimation, that is loaded with a couple of errors such as missing specific information about the source or output scatter from photodiode to photodiode contribute to the estimate's imprecision.

sglux runs a NIST and PTB traceable calibration laboratory where we make absolute measurements with a photodiode. The customer informs us which photodiode will be purchased and which lamp/source will be measured. With that photodiode we then do measurements leading to precise radiation-to-current information.