

General Features



Properties of the ERYCA_advanced photodiode

- DIN5050/ CIE087 UV-Index measurement with very small error $<\pm 3\%$
- TO5 housing, 1 UVI ($2,5 \mu\text{W}/\text{cm}^2$) $\approx 2 \text{ nA}$, cosine correction

Information about the UV-Index (UVI)

The UV index is an international standard measurement of how strong the ultraviolet (UV) radiation from the sun is at a particular place on a particular day. It is a scale primarily used in daily forecasts aimed at the general public. The UV-Index is calculated by integrating the sun's UV spectrum multiplied with the Erythema action curve (fig. 1, black curve and fig. 2, formula 1). That integral is divided by $25 \text{ mW}/\text{m}^2$ to generate a convenient index value, which becomes essentially a scale of 0 to 10. The Erythema action curve is a wavelength resolved measure of the sunburn danger. It is maximised at 297nm (UVB) and then strongly decreases towards UVA radiation. Literature: A. F. McKinlay and B. L. Diffey, "A reference action spectrum for ultraviolet induced erythema in human skin" CIE Journal, 6-1, 17-22 (1987)

About the sglux ERYCA sensors

The ERYCA is designed for accurate measurement of the UV-Index. ERYCA's error is $<3\%$ only which is sufficiently small for scientific and high performance commercial applications. The ERYCA is available as:

ERYCA_custom (SG01M-E18) photodiode, $0,5\text{nA}/\text{UVI}$ ($0,20\text{mm}^2$ SiC detector chip)

ERYCA_advanced (SG01L-E5) cosine corrected photodiode, $2\text{nA}/\text{UVI}$ ($1,0\text{mm}^2$ SiC chip)

ERYCA_science (SG01XL-E5) cosine corrected photodiode, $8\text{nA}/\text{UVI}$ ($4,0\text{mm}^2$ SiC chip)

TOCON_ERYCA pre-amplified cosine corrected hermetically sealed low noise sensor with 5-15V power supply and approx. $100\text{mV}/\text{UVI}$ voltage output (SiC detector chip)

How ERYCA's $<3\%$ error is calculated?

A good erythema sensor's response needs to follow the Erythema Action curve (fig 1) as close as possible. Additionally the visible blindness needs to be extremely high as the visible part of sun's radiation exceeds the erythema causing radiation by five orders of magnitude. ERYCA works with a 4H SiC detector chip providing a visible blindness of more than ten orders of magnitude. That means that absolutely no visible light interferes the sensors output value. Sensors with a visible blindness of less than six orders of magnitude are unsuited for UVI measurement even if they match with the CIE curve. ERYCA's curve (fig. 1, red curve) has a near perfect match from 295nm to 320nm. From 320nm a leakage of approx. 0,1% is seen. To find out how that leakage negatively influences the UVI measurement a closer look at different sun spectra (varying tilt angle and ozone layer thickness) is needed. Fig. 4 shows different sun UV spectra issued by the Swiss governmental institute of meteorology. In total nine different sun spectra calculating an UVI from 1,12 to 10,92 were used. For error calculation the different sun spectra were integrated with the Erythema action curve and subsequently the integral of the same spectra with ERYCA's response curve (fig. 2, formula 1 and 2) were calculated. Finally the error was calculated by using formula 3 (fig. 2). As shown by the blue curve (fig. 3) the error of all UVI is less than 3%.

Fig. 1 Spectral Response

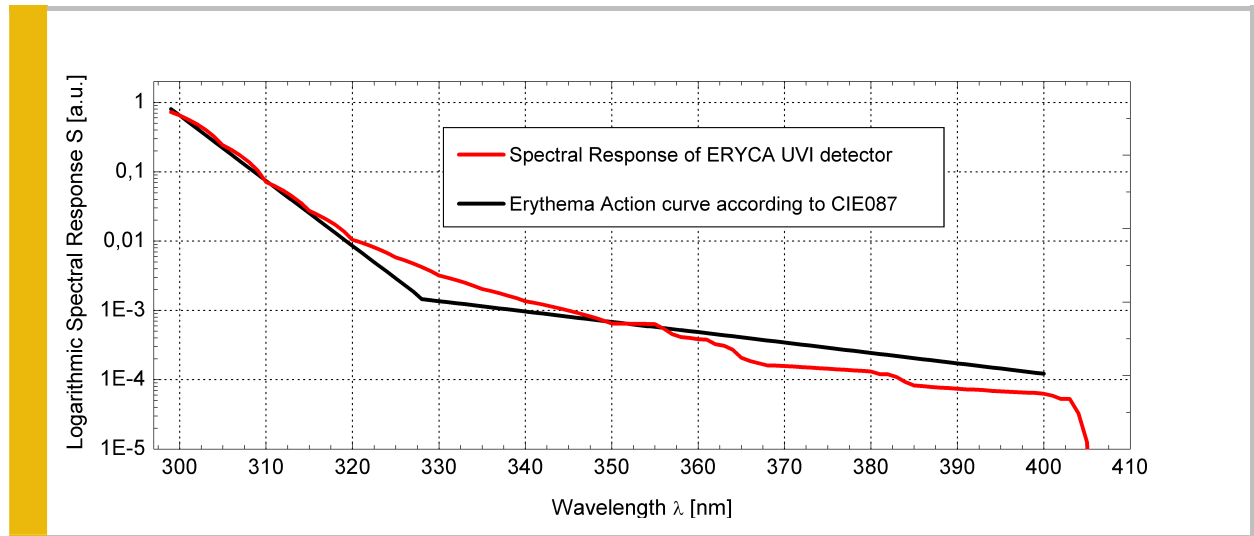

Fig. 2 Calculation Formulae

$$UVI_{ideal} = \int_{\lambda=297\text{ nm}}^{\lambda=400\text{ nm}} \frac{S(\lambda) \cdot CIE(\lambda)}{25\text{mW/m}^2} d\lambda \quad (1)$$

$$UVI_{real} = \int_{\lambda=297\text{ nm}}^{\lambda=400\text{ nm}} \frac{S(\lambda) \cdot ERYCA(\lambda)}{25\text{mW/m}^2} d\lambda \quad (2)$$

$$E = \frac{(UVI_{ideal} - UVI_{real}) \cdot 100}{UVI_{ideal}} \quad (3)$$

Legend
 S(λ) = sun UV spectrum
 CIE(λ) = CIE087 standard curve
 ERYCA(λ) = ERYCA response curve
 E = error in %

Fig. 3 Error Graph

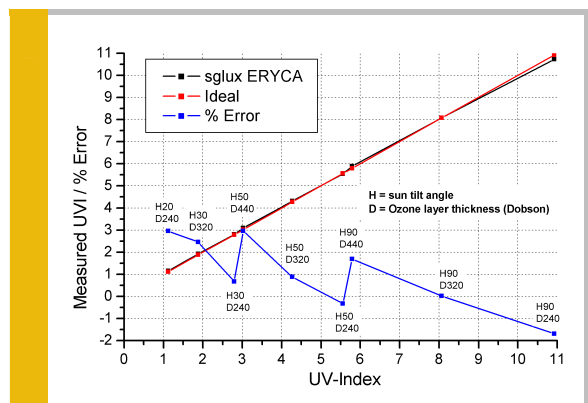
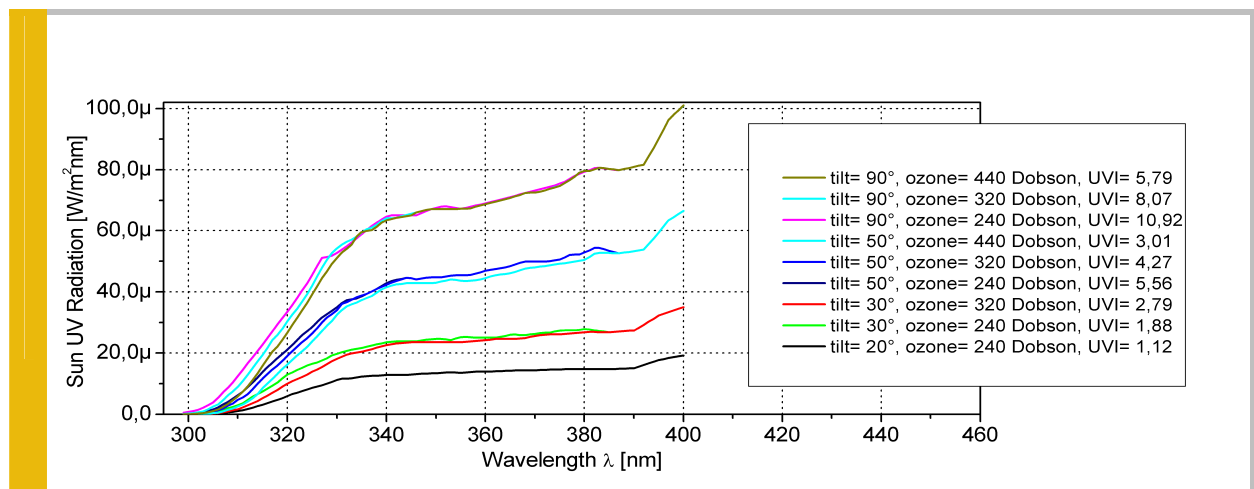

Fig. 4 Sun Spectra Issued by the Swiss Meteo Institute



Specifications

Parameter	Symbol	Value	Unit
Maximum Ratings			
Operating Temperature Range	T_{opt}	-55 ... +120	°C
Storage Temperature Range	T_{stor}	-55 ... +120	°C
Soldering Temperature (3s)	T_{sold}	260	°C
Reverse voltage	V_{Rmax}	20	V
General Characteristics (T=25°C)			
Active Area	A	1,00	mm ²
Dark current (1V reverse bias)	I_d	4	fA
Capacitance	C	200	pF
Short circuit (1 UVI)	I_0	2	nA
Temperature coefficient	T_c	<-0,1	%/K

Circuit

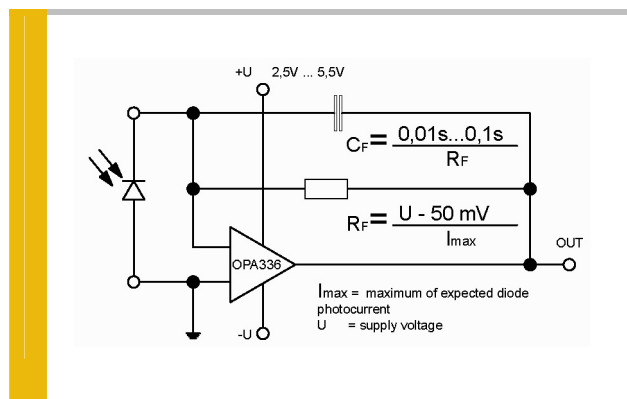

Viewing Angle

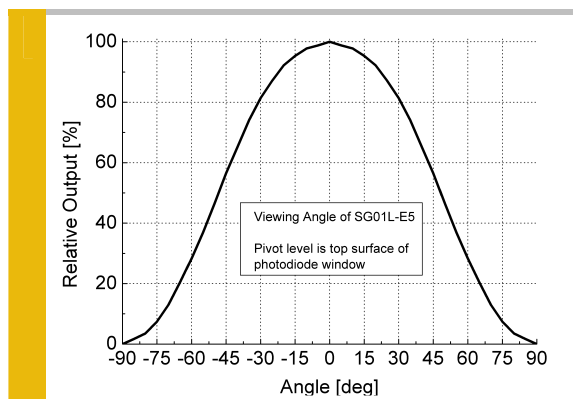

Drawing

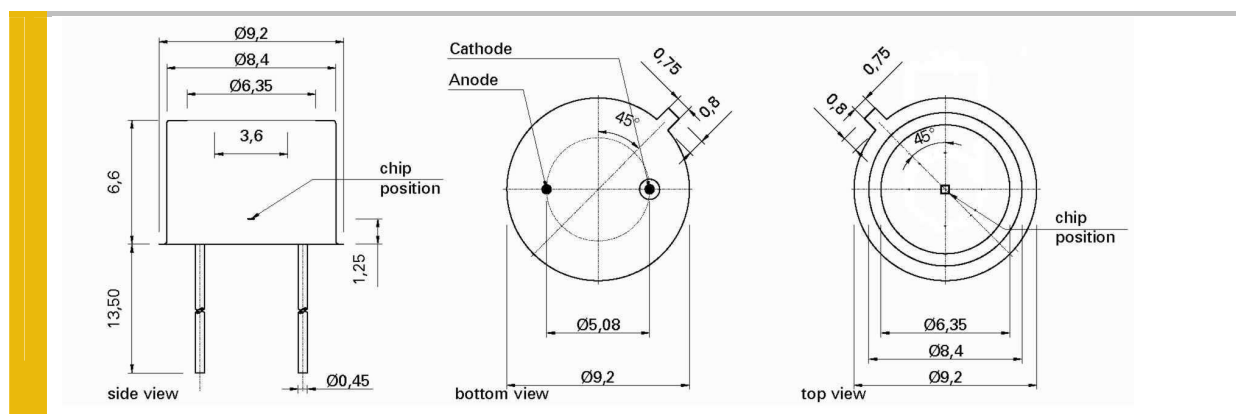

Application Note

For correct reading of the photodiode the current (and NOT the voltage) must be analyzed. This requires a short circuiting of the photodiode. Usual approaches are using a **Picoamperemeter** such as Keithley 617 or a **transimpedance amplifier** circuit as shown on page 2 of this datasheet. Please contact us in case of questions.

The below listed modules help you to get the best measurement information from your photodiode.

Internal & external Photodiode Amplifiers

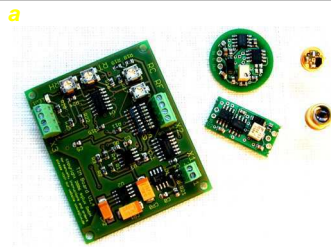

- stable and reliable photodiode amplification
- TOCON-Series = photodiodes with integrated amplifier
- BOARD-Series = external photodiode amplifiers
- further information: www.sglux.com/tocon or www.sglux.com/boards

UV probes with built in amplifier



- different housings e.g. with cosine response, water pressure proof or Sapphire windows
- different electronic outputs available (voltage, current, USB)
- further information: www.sglux.com/probes

UV Intensity / Dose Monitor / Controller ‘SENSOR MONITOR’



- two channel photodiode or sensor input
- three user programmable relay outputs
- programmable display, USB/TTY/RS232 data transmission
- further information: www.sglux.com/monitor

UV Radiation Controller ‘RADIKON’



- Industrial DIN rail radiation controller module
- works with mV and nA....mA sensor output signals
- further information: www.sglux.com/radikon