



PCI-M Series IR Photoconductors

FAST 2-6 μm IR PHOTOCONDUCTORS ROOM TEMPERATURE, OPTICALLY IMMERSED

FEATURES

- ambient temperature operation
- *spectral range of 2-6 μm
- * $D^* = 10^8 - 10^{11} \text{ cmHz}^{1/2}/\text{W}$
- fast response time
- low bias power requirements
- wide dynamic range
- lightweight, rugged and reliable

SPECTRAL RESPONSE

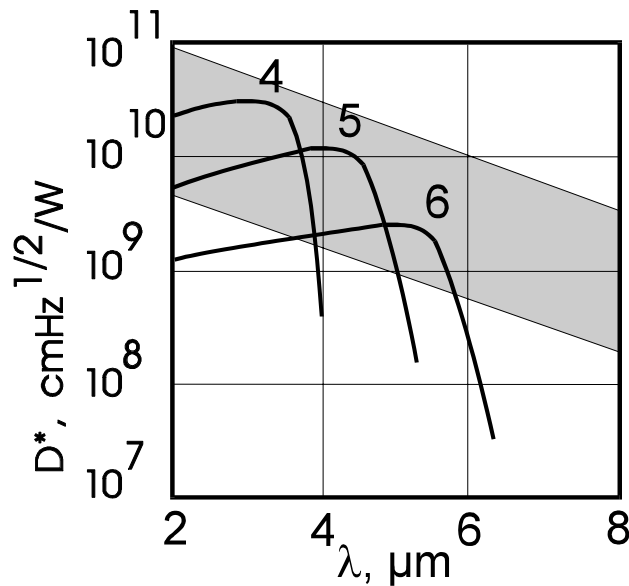

Spectral detectivity of PCI-4, -5 and -6 detectors.

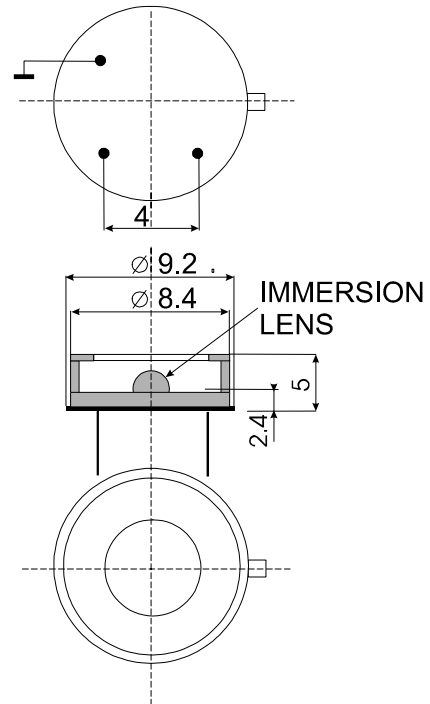
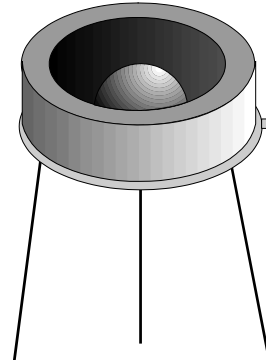

Devices are typically mounted in modified TO-5 cans, with no windows. Other housings with different windows are available upon request.



DESCRIPTION

The PCI series photodetectors are uncooled IR photoconductors optically immersed on high refractive index CdTe hyperhemispherical lenses. These devices can be optimized for maximum performance anywhere from 2 to 12 μm . In this spectral region, these detectors perform better than all other uncooled detectors at moderate to high frequencies, but exhibit 1/f noise below 10kHz.

Such extraordinary performance is achieved by using a newly developed variable gap semiconductor (Hg-Cd-Zn-Te) as well as with graded composition and doping level profiles and optimization of surface processing.

SPECIFICATIONS

Specifications are subject to change without notice. Specifications measured @20°C, 1x1 active area.

Characteristics	Units	PCI-M-4	PCI-M-5	PCI-M-6
Optimization Wavelength	μm	4	5	6
Detectivity (λ_p , 20 kHz)	$\text{cmHz}^{1/2}/\text{W}$	$>2 \times 10^{10}$	$>6 \times 10^9$	$>1 \times 10^9$
Detectivity (λ_{op} , 20 kHz)	$\text{cmHz}^{1/2}/\text{W}$	$>6 \times 10^9$	$>2 \times 10^9$	$>5 \times 10^8$
Responsivity \times Widths at λ_p	$\text{V mm}/\text{W}$	700	180	20
Responsivity \times Widths at λ_{op}	$\text{V} \times \text{mm}/\text{W}$	>200	>60	>10
Response time	nsec	<1000	<300	<200
1/f Corner Frequency	kHz	0.5 - 5	0.5 - 5	1 - 10
Resistivity	Ω	300 - 500	150 - 300	50 - 200
Area (optical)	mm^2	0.05 \times 0.05; 0.1 \times 0.1; 0.2 \times 0.2; 0.5 \times 0.5; 1 \times 1, 2 \times 2; 3 \times 3		
Field of view	deg	>40		

TYPICAL OPERATING CIRCUIT

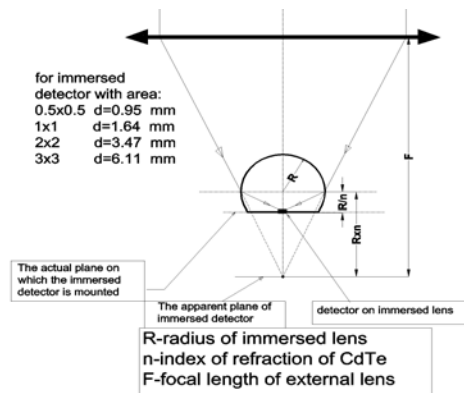
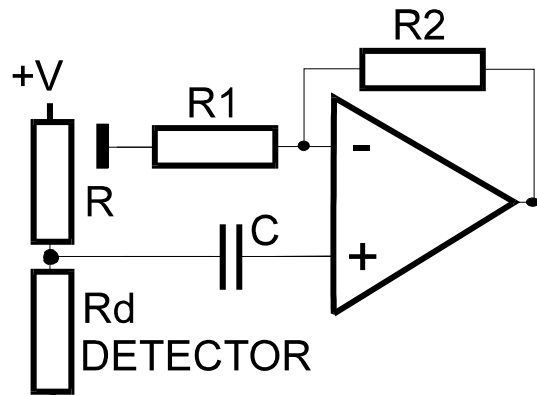

CAUTION

- CW optical power must not exceed 20 W/cm²!
- Pulses shorter than 1 μs must not exceed 10 kW/cm²!
- Avoid overbiasing of detector!

More Information: see J. Piotrowski et al., "New generation of near-room temperature photodetectors", Optical Engineering, May 1994, Vol. 33 No. 5, pages 1413-1421

We supply compatible low-noise preamplifiers with bandwidths AC-coupled, to 500+ MHz.

