



# PCI-2TE Series IR Photoconductor

## 2-12μm Spectrally Tailored IR Photoconductors Thermoelectrically Cooled, Optically Immersed

### FEATURES

- high performance in the 2-12μm range *without* LN<sub>2</sub>-cooling!
- fast response
- convenient to use
- wide dynamic range
- compact, rugged and reliable
- low cost

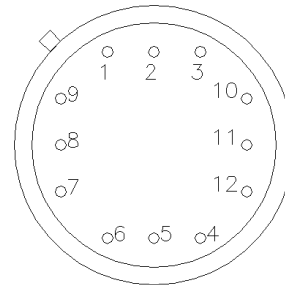

- 1 - Detector (+)
  - 2 - TE Cooler (+)
  - 3 - Detector (-)
  - 4 - Thermistor
  - 5 - TE Cooler (-)
  - 6 - Thermistor
  - 7 - Not in use
  - 8 - Ground
  - 9 - Ground
  - 10 - Not in use
  - 11 - Not in use
  - 12 - Not in use
- (BOLT-DOWN ONLY)  
(ALL OTHER)

### SPECTRAL RESPONSE

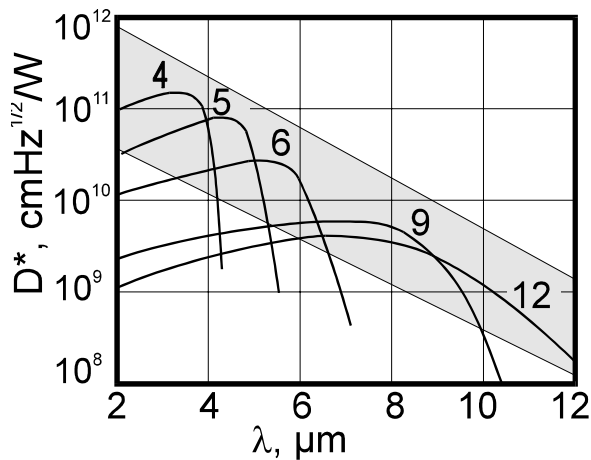

Typical spectral detectivities of PCI-2TE-series photoconductors at 100 kHz. 1/f noise is a consideration below 10 kHz.

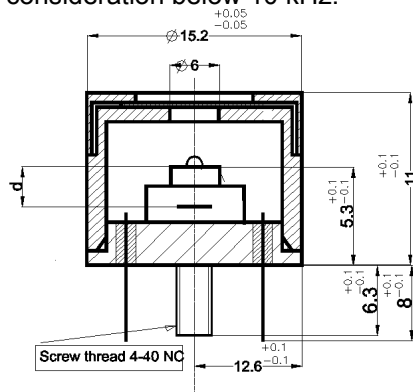
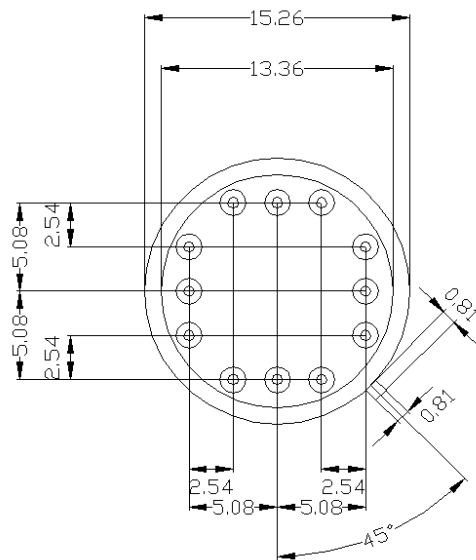

PCI-L-2TE photodetectors incorporate industry standard two-stage low-power thermoelectric coolers and are packaged in modified TO-8-style cans. For proper operation, the units **must** be mounted on an appropriate heat sink to dissipate the heat generated by TE cooler.



## DESCRIPTION

PCI-2TE-n series photodetectors (where n is wavelength  $\lambda_{op}$ , in micrometers, for which the detector is optimized) are two-stage TE-cooled IR photoconductors which have been optically immersed on high refractive index CdZnTe hyperhemispherical lenses. These devices can be optimized for maximum performance anywhere from 2 to 12  $\mu\text{m}$ . High performance and stability are achieved by using newly developed variable gap semiconductor Hg-Cd-Zn-Te as well as graded composition and doping level profiles and optimized surface processing.

## SPECIFICATIONS

Specifications are subject to change without notice. Specifications measured @20°C, 1x1 active area.

Characteristics	Units	PCI-2TE-4	PCI-2TE-5	PCI-2TE-6	PCI-2TE-9	PCI-2TE-12
Optimization Wavelength	$\mu\text{m}$	4	5	6	9	12
Detectivity at $\lambda_p$	$\text{cmHz}^{1/2}/\text{W}$	$>1 \cdot 10^{11}$	$>5 \cdot 10^{10}$	$>3 \cdot 10^{10}$	$>2 \cdot 10^9$	$>1 \cdot 10^9$
Detectivity at $\lambda_{op}$	$\text{cmHz}^{1/2}/\text{W}$	$>7 \cdot 10^{10}$	$>2 \cdot 10^{10}$	$>1 \cdot 10^{10}$	$>7 \cdot 10^8$	$>1 \cdot 10^8$
Responsivity $\times$ Width at $\lambda_p$	$\text{Vxmm}/\text{W}$	$>1000$	$>900$	$>500$	$>150$	$>10$
Responsivity $\times$ Width at $\lambda_{op}$	$\text{Vxmm}/\text{W}$	$>500$	$>400$	$>100$	$>30$	$>1$
Response Time	nsec	$<3000$	$<1000$	$<100$	$<30$	$<10$
1/f Corner Frequency	kHz	0.4 - 4	0.6 - 6	0.8 - 8	1 - 10	1 - 10
Sheet resistivity	$\Omega$ per $\square$	300 - 400	180 - 300	150 - 200	80 - 160	50 - 80
Bias Current-Width Ratio*	$\text{mA}/\text{mm}$	1 - 8	2 - 10	2 - 12	3 - 15	4 - 25
Active Area, Length $\times$ Width	$\text{mm} \times \text{mm}$	0.1 $\times$ 0.1; 0.25 $\times$ 0.25; 0.5 $\times$ 0.5; 1 $\times$ 1; 2 $\times$ 2				
Field of View	deg	42 (60)**				
Operating Temperature.	K	220-230				

\*Recommended detector and cooler bias currents are specified with each detector.

\*\*60° FOV available only for hemispherically immersed devices; D\* reduced by a factor of 2.

## TYPICAL OPERATING CIRCUIT

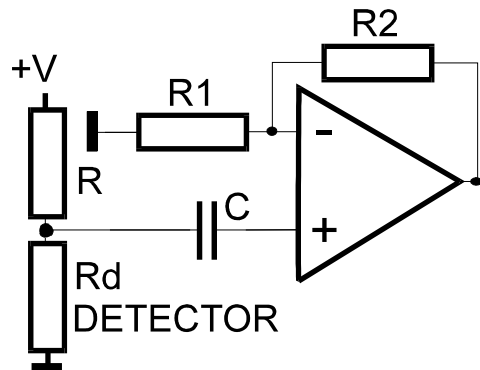

## CAUTION

- CW optical power must not exceed 20  $\text{w}/\text{cm}^2$ !
- Pulses shorter than 1  $\mu\text{s}$  must not exceed 10  $\text{kw}/\text{cm}^2$ !
- Avoid overbiasing of detector!
- Avoid overbiasing and opposite polarity biasing of te-cooler!

