

Features

- Special UV-index sensor, precision up to +/- 0.5 UVI
- Optimally suited for accurate sun-UV dosimetry
- Also suited for sun tanning bank dosimetry
- Silicon Carbide based chip for radiation hardness
- Intrinsic visible blindness due to wide-bandgap semiconductor material
- TO-18 metal package with integrated filter glass
- 0,054 mm² active chip area
- The chip is manufactured by Cree Research Inc., U.S.A.

Eigenschaften

- Spezieller UV-Index Sensor mit einer Genauigkeit bis zu +/- 0.5 UVI
- Optimale Eignung für präzise Messung des Sonnen-UV
- Auch geeignet zur Überwachung von Solarien
- Siliziumkarbid-Chip garantiert hohe Strahlungsfestigkeit
- Inhärente Unempfindlichkeit gegenüber dem sichtbaren Licht durch das Halbleitermaterial mit hoher Bandlücke
- TO-18 Metallgehäuse mit integriertem Filterglas
- 0,054 mm² aktive Chipfläche
- Chiphersteller: Cree Research Inc., U.S.A.

Maximum Ratings

Parameter	Symbol	Value	Unit
Operating temperature range	T_{opt}	-25 ... +70	°C
Reverse voltage	V_{Rmax}	20	V

General Characteristics

($T_a = 25\text{ °C}$)

Parameter	Symbol	Value	Unit
Active area	A	0.054	mm ²
Dark current at 1 V reverse bias	I_d	1	fA
Capacitance	C	21	pF
Short circuit current at bright sun	I_0	ca. 7	nA

Spectral Characteristics

($T_a = 25\text{ °C}$)

Parameter	Symbol	Value	Unit
Max. spectral sensitivity	S_{max}	0.11	A W ⁻¹
Wavelength of max. spectral sensitivity	λ_{Smax}	295	nm
Range of spectral sensitivity ($S=0.1 \cdot S_{max}$)	-	235 - 325	nm

Linear Spectral Response

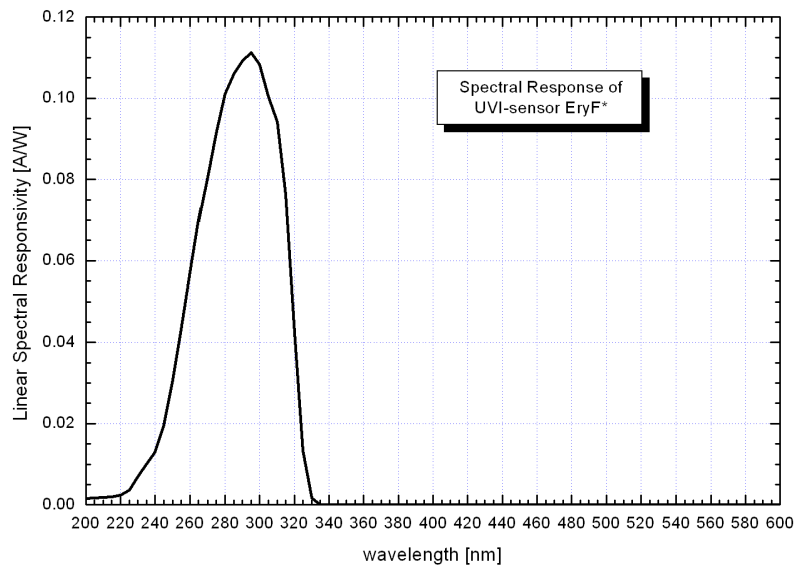

Logarithmic Spectral Response

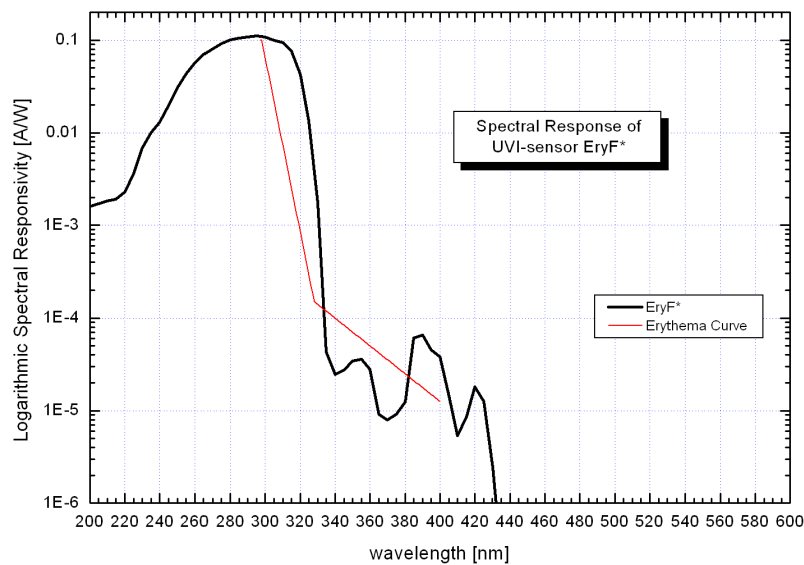

Application Example

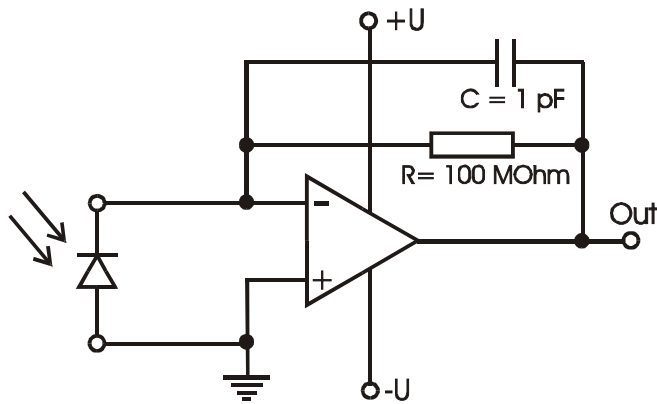

Pin Layout

Grounded pin: Anode
Isolated pin: Cathode

