

Digital UV SENSOR “DIGIPROBE”

High resolution UV measurement in a wide dynamic range



Digiprobe in a UV-Surface housing

The Digiprobe is a digital UV Sensor for high resolution radiation measurement in a wide, dynamic range. It is used for high precision measurements and universally for various radiation levels. Precision measurements, e.g., can be up to a UV intensity of $1\text{mW}/\text{cm}^2$ with a resolution of $10\text{nW}/\text{cm}^2$. A temperature sensor is integrated in the sensorhead, providing a numerical temperature compensation of the irradiation measurement value.

The detector signal is digitalized directly at the measuring point to minimize electromagnetic disturbances. A shield includes the housing and cable and provides excellent EMC conditions. The sensor delivers a CAN signal for integration into CAN bus networks and which can result in the parallel operation of up to 254 sensors. For non-industrial users the „Digibox“ is additionally provided. Up to ten sensors can be connected to this CAN to USB converter box to transfer the measurement data to a PC.

The comfortable software „DigiLog“ shows the data and trends of intensity and temperature measurements. The software can be used to change measurement and calibration parameters. All calibration dates and sensor information are stored in the sensorhead.

The detectors for UV measurement are based upon a radiation hard Silicon Carbide (SiC) UV photodiode with long term stability and a visible blindness above 10^{10} (ratio of UV to Vis-IR sensitivity).

The Digiprobe is used for high precision UV measurements in laboratories as well as in industrial applications where an array of different measurements within a wide, dynamic range are demanded.

Feature Overview

Measurement	Wide dynamic range, high resolution, temperature measurement, temperature compensation, radiation hard Silicon Carbide (SiC) detector, spectral sensitivity: UV broadband, UVA, UVB, UVC, UV-Index (or $V-\lambda$ with Si photodiode)
Software	DigiLog, multi-channel trends, calibration function, data logging
Output	CAN bus signal
Accessories	Digibox for conversion into a USB signal



Digital UV SENSOR "DIGIPROBE"

High resolution UV measurement in a wide dynamic range



Specifications	Wert	Einheit
Data interface	CAN/USB	-
degree of protection	IP67	-
Operation temperature	-40....+80	°C
storage temperature	-40... +85	°C
power supply	4,5...20	V _{DC}
power consumption (24V)	25	mA
weight	0,16	kg
max. measurement rate irradiation	13,75	Hz
max. measurement rate temperature	13,75	Hz

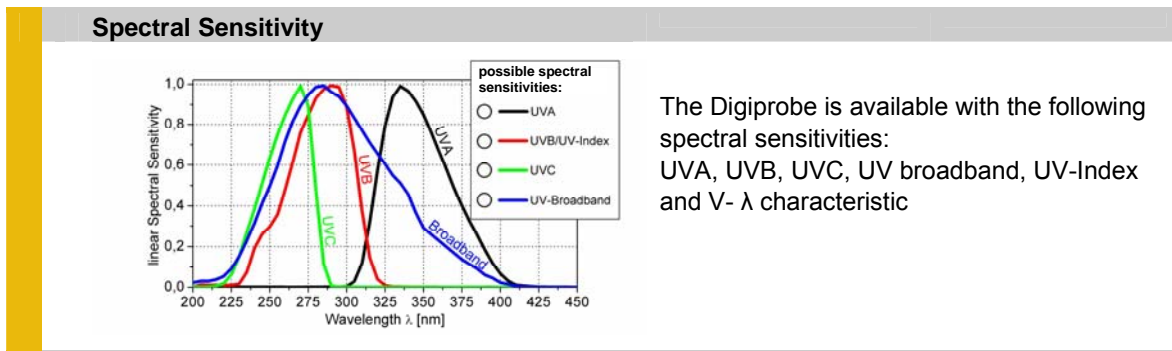

The Digiprobe is available with the following spectral sensitivities: UVA, UVB, UVC, UV broadband, UV-Index and V- λ characteristic

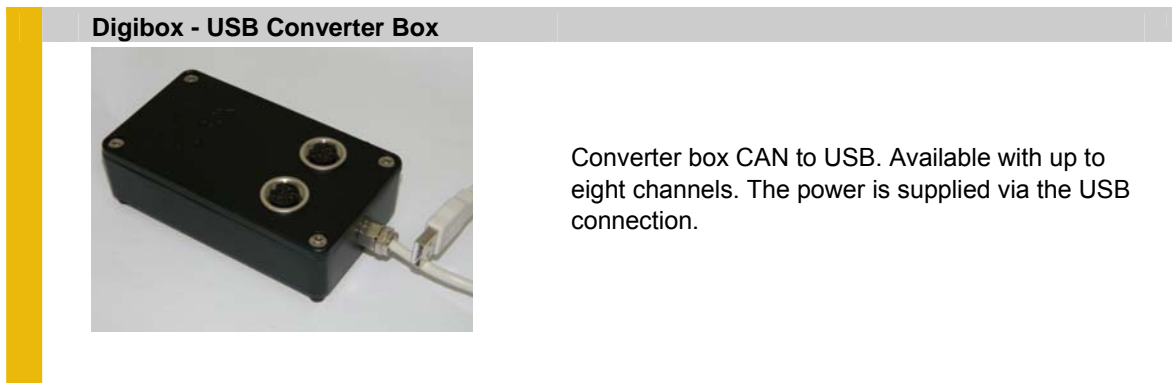
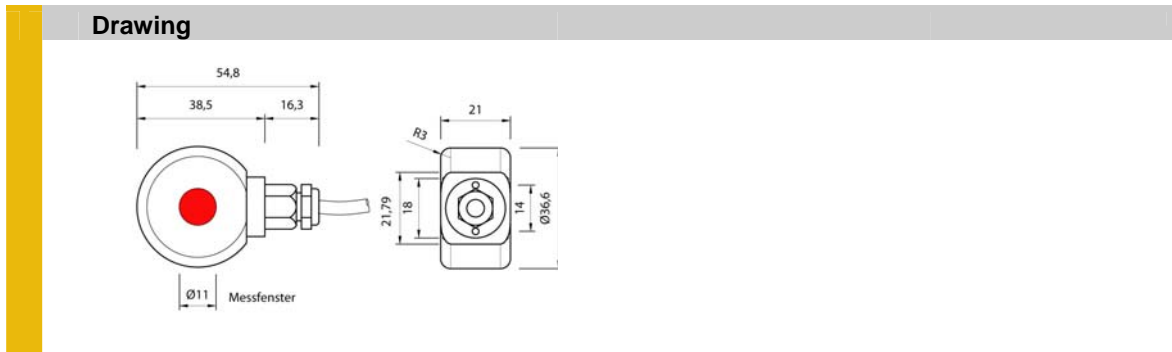

Digital UV SENSOR “DIGIPROBE”

High resolution UV measurement in a wide dynamic range

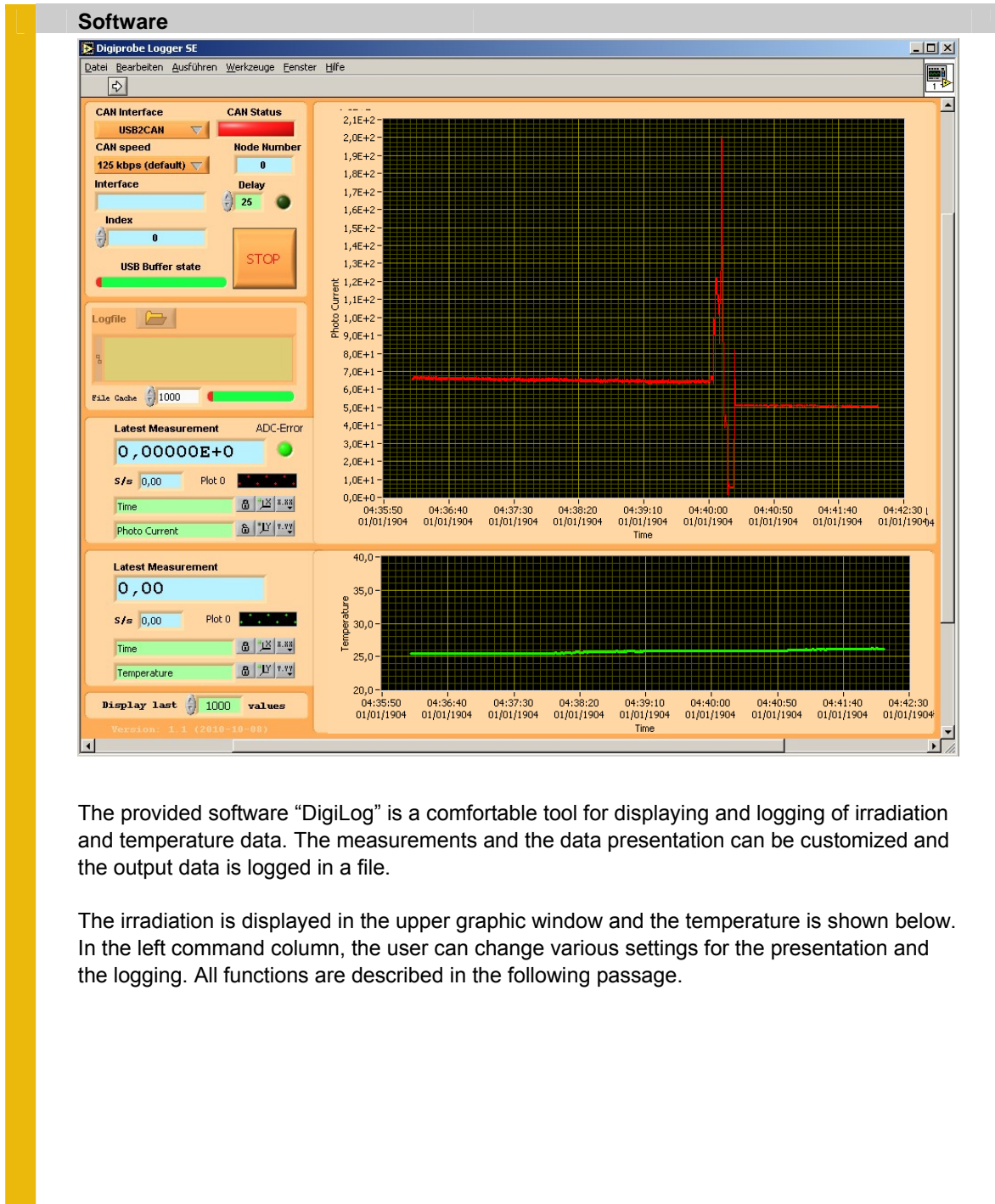

The provided software “DigiLog” is a comfortable tool for displaying and logging of irradiation and temperature data. The measurements and the data presentation can be customized and the output data is logged in a file.

The irradiation is displayed in the upper graphic window and the temperature is shown below. In the left command column, the user can change various settings for the presentation and the logging. All functions are described in the following passage.



Software Functions in Detail

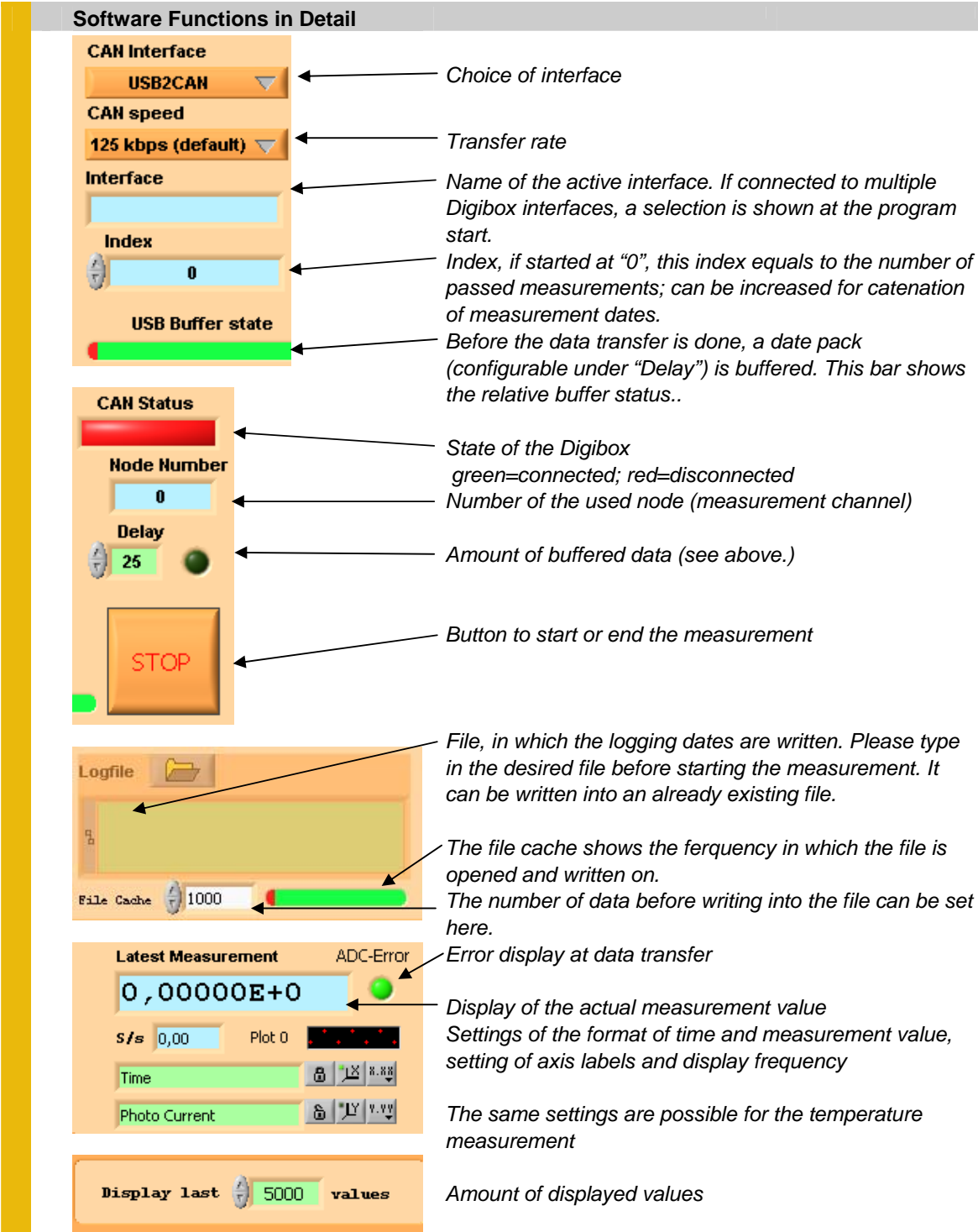

The screenshot shows the software interface with several sections and their corresponding annotations:

- CAN Interface**:
 - USB2CAN**: Choice of interface
 - CAN speed**: 125 kbps (default) - Transfer rate
 - Interface**: Name of the active interface. If connected to multiple Digibox interfaces, a selection is shown at the program start.
 - Index**: 0 - Index, if started at “0”, this index equals to the number of passed measurements; can be increased for catenation of measurement dates.
 - USB Buffer state**: A green bar showing the relative buffer status..
- CAN Status**:
 - Node Number**: 0 - State of the Digibox (green=connected; red=disconnected) and Number of the used node (measurement channel)
 - Delay**: 25 - Amount of buffered data (see above.)
 - STOP**: Button to start or end the measurement
- Logfile**:
 - File Cache**: 1000 - File, in which the logging dates are written. Please type in the desired file before starting the measurement. It can be written into an already existing file.
 - File Cache**: 1000 - The file cache shows the frequency in which the file is opened and written on.
 - File Cache**: 1000 - The number of data before writing into the file can be set here.
- Latest Measurement**:
 - ADC-Error**: Error display at data transfer
 - 0,00000E+0**: Display of the actual measurement value
 - s/s 0,00** and **Plot 0**: Settings of the format of time and measurement value, setting of axis labels and display frequency
 - Time** and **Photo Current**: The same settings are possible for the temperature measurement
- Display last**: 5000 values - Amount of displayed values



Software – Command Window

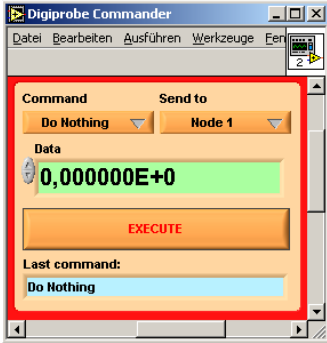

In the command window all basic settings like changing of calibration values are done.

Caution: values are changed permanently. Preset calibration values will get lost!

procedure:

1. Chose command
2. Chose knode (measurement channel), which should receive the command.
3. Setting of new value (if applicable: note preset value)
4. klick “execute”

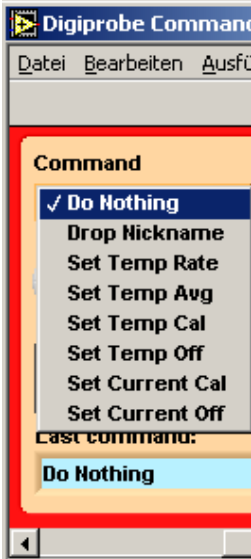

At the Command drop-down menue the following choices can be done:

- No action
- New knode name¹⁾
- Measurement rate temperature²⁾
- Averaging, currently without function
- Calibration temperature sensor
- Offset calibration of temperature sensor
- Calibration irradiation sensor³⁾
- Offset calibration of irradiation sensor

¹⁾The default node name can be changed here. This may be necessary if conflicts occur caused by multiple remitted names.

²⁾ This measurement rate is chosen in relation to the measurement rate of the irradiation, which is measured constantly with 13,75Hz. Irradiation and temperature are measured after another.
That means:
1=measurement with 13,75Hz
2=measurement after each 2nd irradiation measurement
...

³⁾ Calibration of irradiation:

- 1- set calibration value to 1, set offset to 0,
- 2- dark measurement, determine offset
- 3- balance offset
- 4- determine calibration value
- 5- set calibration value

