

AG32S

UVB sensitive AlGaN based UV photodiode $A = 0,076 \text{ mm}^2$

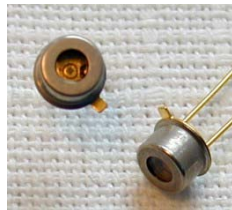

General Features



Properties of the AG32S UV photodiode

- UVB sensitive photodiode
- Active Area $A = 0,076 \text{ mm}^2$
- TO18 metal housing
- 10 mW/cm^2 peak radiation results a current of approx. 700 nA

About the material (Aluminium)Gallium Nitride (Al)GaN

(Al)GaN is a new semiconductor material for visible blind UV photodiodes. By modification of the Al – to - Ga stoichiometry it is possible to produce photodiodes with different spectral behaviour. This allows to offer Photodiodes sensible for broad band UV (UVA+UVB+UVC), for UVB-only and for UVC only without using a filter.

Specifications

Parameter	Symbol	Value	Unit
Maximum Ratings			
Operating Temperature Range	T_{opt}	-25 ... +70	°C
Storage Temperature Range	T_{stor}	0 ... +100	°C
Soldering Temperature (3s)	T_{sold}	260	°C
Reverse voltage	V_{Rmax}	5	V
General Characteristics (T=25°C)			
Active Area	A	0,076	mm^2
Dark current (1V reverse bias)	I_{d}	100	fA
Capacitance	C	24	pF
Short circuit (10mW/cm ² at peak)	I_{o}	700	nA
Temperature coefficient	Tc	<-0,3	%/K
Spectral Characteristics (T=25°C)			
Max. spectral sensitivity	S_{max}	0,130	AW^{-1}
Wavelength of max. spectral sens.	λ_{max}	310	nm
Sensitivity range ($S=0,1 \cdot S_{\text{max}}$)	-	240 ... 320	nm
Visible blindness ($S_{\text{max}} / S_{>400\text{nm}}$)	VB	10^3	-

AG32S

UVB sensitive AlGaN based UV photodiode $A = 0,076 \text{ mm}^2$



Spectral Response

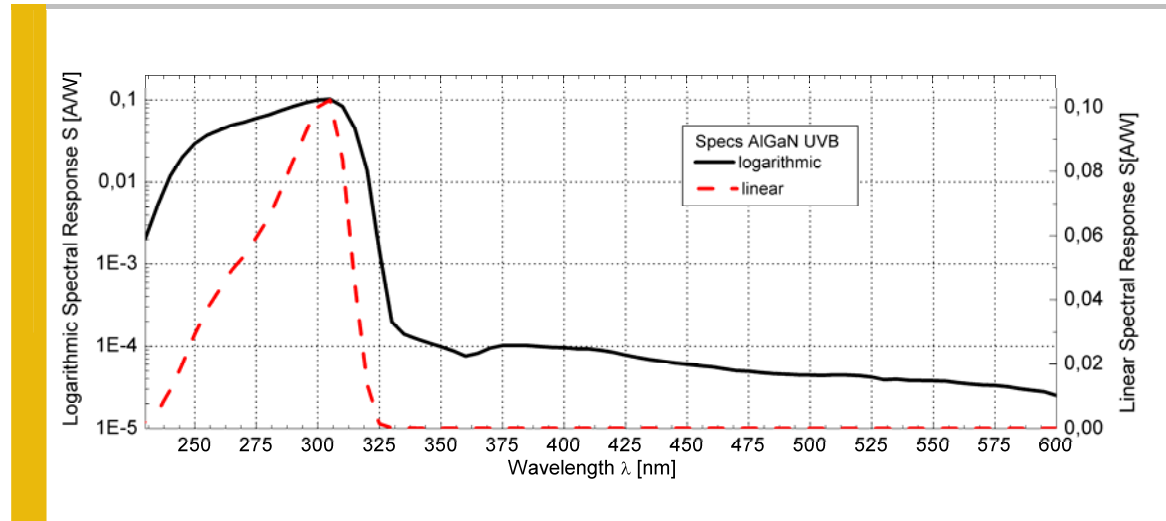

Circuit

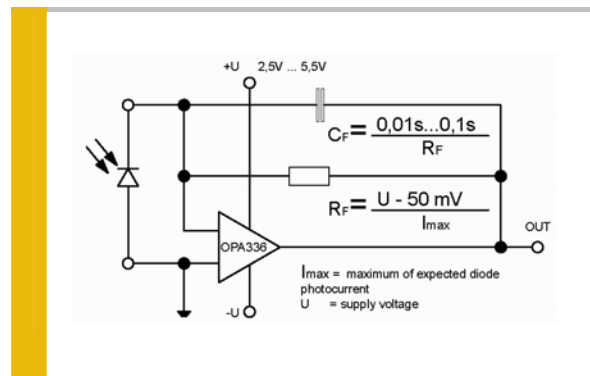

Viewing Angle

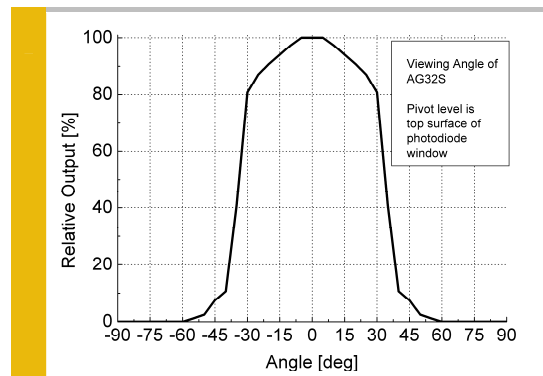

Drawing

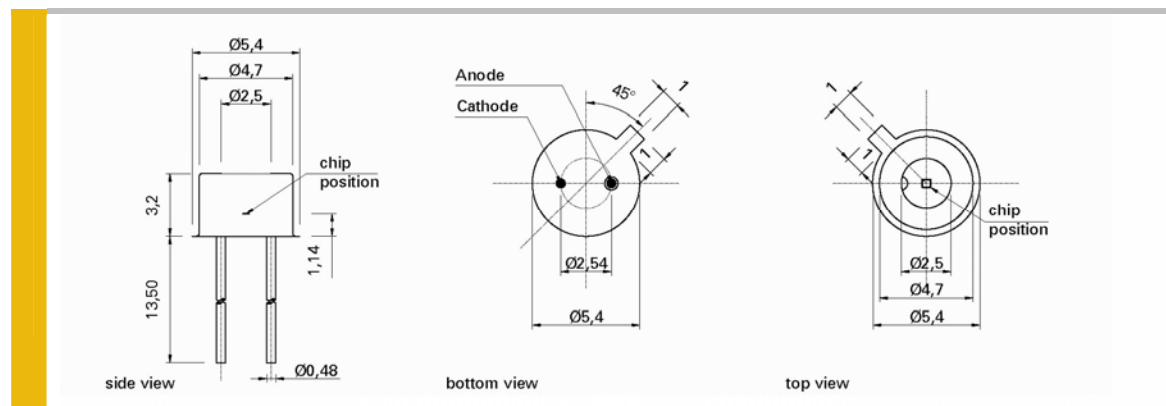

Application Note

For correct reading of the photodiode the current (and NOT the voltage) must be analyzed. This requires a short circuiting of the photodiode. Usual approaches are using a **Picoamperemeter** such as Keithley 617 or a **transimpedance amplifier** circuit as shown on page 2 of this datasheet. Please contact us in case of questions.

The below listed modules help you to get the best measurement information from your photodiode.

Internal & external Photodiode Amplifiers



- stable and reliable photodiode amplification
- TOCON-Series = photodiodes with integrated amplifier
- BOARD-Series = external photodiode amplifiers
- further information: www.sglux.com/tocon or www.sglux.com/boards

UV probes with built in amplifier



- different housings e.g. with cosine response, water pressure proof or Sapphire windows
- different electronic outputs available (voltage, current, USB)
- further information: www.sglux.com/probes

UV Intensity / Dose Monitor / Controller "SENSOR MONITOR"



- two channel photodiode or sensor input
- three user programmable relay outputs
- programmable display, USB/TTY/RS232 data transmission
- further information: www.sglux.com/monitor

UV Radiation Controller "RADIKON"



- Industrial DIN rail radiation controller module
- works with mV and nA....mA sensor output signals
- further information: www.sglux.com/radikon