



Scitec Instruments Ltd

Bartles Industrial Estate Tel: +44 (0)1209 314 608 scitec@scitec.uk.com
North Street, Redruth Fax: +44 (0)1209 314 609 www.scitec.uk.com
Cornwall TR15 1HR Fax2: +44 (0)870 1600 860

**MODEL 442 ANALOGUE OEM
DUAL PHASE LOCK-IN AMPLIFIER**

**WITH MICRO-PROCESSOR INTERFACE
USER MANUAL V1.1**



Scitec Instruments Ltd

Bartles Industrial Estate Tel: +44 (0)1209 314 608 scitec@scitec.uk.com
North Street, Redruth Fax: +44 (0)1209 314 609 www.scitec.uk.com
Cornwall TR15 1HR Fax2: +44 (0)870 1600 860

CONTENTS

| | |
|---|----|
| 1 SPECIFICATIONS..... | 2 |
| 2 BOARD LAYOUT | 3 |
| 3 OPERATION | 4 |
| 3.1 Basic Lock-in Amplifier Theory | 4 |
| 3.2 Full Lock-in Amplifier Theory | 4 |
| 3.3 Circuit Description..... | 4 |
| 3.3.1 Block Diagram | 4 |
| 3.3.2 Input Mode Select | 5 |
| 3.3.3 Input Stage Gain | 6 |
| 3.3.4 Demodulator..... | 6 |
| 3.3.5 Low Pass Filter..... | 7 |
| 3.3.6 Output Stage Gain..... | 8 |
| 3.3.7 Reference Circuitry | 8 |
| 4 OVERALL SYSTEM GAIN AND DYNAMIC RESERVE..... | 10 |
| 4.1 Dynamic Reserve..... | 10 |
| 4.2 Maximum Signal Size Up To The Low Pass Filter | 11 |
| 4.3 Maximum Signal Size From Low Pass Filter to Output | 11 |
| 4.4 Example Gain Settings | 12 |
| 5 CONNECTIONS | 16 |
| 5.1 DIN41612 Connector | 16 |
| 5.2 30 Way IDC Connector | 17 |
| 6 POWER SUPPLY | 19 |
| 6.1 Power Connections..... | 19 |
| 6.2 Earth Connections for High Voltage / ESD Protection | 19 |
| 6.3 Analogue and Digital Ground..... | 19 |
| 7 WRITING CONTROL DATA TO THE BOARD | 21 |
| 7.1 Setting Fine Phase and Output Offset..... | 22 |
| 7.2 Input Stage Settings..... | 24 |
| 7.3 Output Stage Settings..... | 27 |
| 7.4 Reference Settings | 29 |



Scitec Instruments Ltd

Bartles Industrial Estate Tel: +44 (0)1209 314 608 scitec@scitec.uk.com
North Street, Redruth Fax: +44 (0)1209 314 609 www.scitec.uk.com
Cornwall TR15 1HR Fax2: +44 (0)870 1600 860

1 SPECIFICATIONS

Input Stage

Input Signal Modes: Single Ended or Fully Differential, AC or DC coupled.

Input Gain: x1, x3.3, x10, x33, x100, x330, x1000

Analogue Connections: SMB connectors

Input Impedance: 10^{12} Ohms || 1nF, dc coupled

Maximum Inputs: ± 12 V DC before saturation occurs.

Gain Accuracy: 1%

Gain Stability: 200ppm/ $^{\circ}$ C

Frequency: 10Hz to 100kHz

Output Stage

Outputs: X, Y and R

Output Gain: x1, x10, x100, x1000 (Equivalent to Dynamic Reserves of 0dB, 20dB, 40dB and 80dB respectively)

Time Constant Settings: 100 μ s, 330 μ s, 1ms, 3.3ms, 10ms, 33ms, 100ms, 330ms, 1s, 3.3s, 10s, 33s

Output Offset Trim: ± 1 V in 256 steps

Reference Stage

Frequency: 10Hz to 100kHz

Signal Types: Standard TTL or CMOS with mark to space ratio from 1:10 to 10:1. Rising edges only used by the instrument. Sine, triangular, square waves, etc. with amplitudes from 200mV to 10V rms.

Fine Phase Adjust: 0° to 150° in 256 steps

Coarse Phase Adjust: 0° , 90° , 180° & 270° @ reference frequency
 0° , 90° , 180° & 270° @ 2 x reference frequency

Bypass: Both the coarse and fine phase circuitry can be bypassed using jumpers.

General

Size: 100x160mm - Standard Eurocard

Digital Connector: 64 pin type C DIN41612
34 pin IDC connector

Power: 75mA @ +15V, 0V, 60mA @ -15V

The device will also operate from ± 12 V but with reduced headroom

Computer Interface: 8 bit interface with Chip Select and Write signals.

All settings are undefined at power up.

The interface can be directly connected to the Parallel Port of a PC. DOS based software to control the lock-in amplifier board from the PC is included together with source code.



2 BOARD LAYOUT

The 442 board layout is shown in Figure 1.

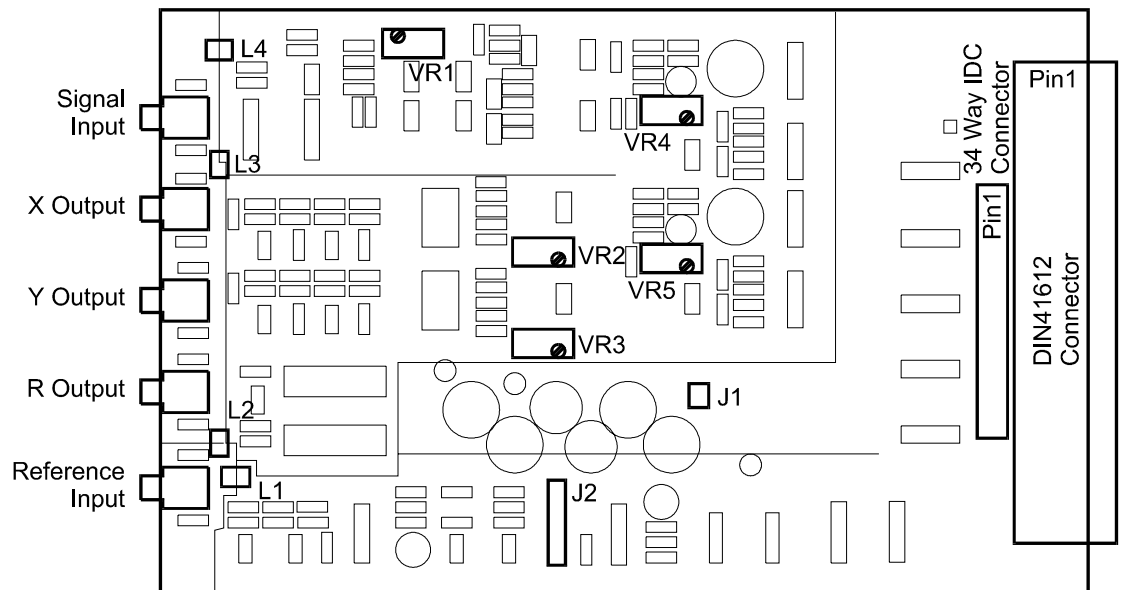

Figure 1 - 442 Board Layout

- | | |
|---------|--|
| L1 - L4 | Electro-Static Discharge Links |
| J1 | Jumper that connects Analogue to Digital Gnd |
| J2 | Allows the phase shifting circuitry to be bypassed |
| VR1 | Signal feed through trim pot |
| VR2 | Channel X gain adjust trim pot |
| VR3 | Channel Y gain adjust trim pot |
| VR4 | Channel X offset adjust trim pot |
| VR5 | Channel Y offset adjust trim pot |



3 OPERATION

3.1 Basic Lock-in Amplifier Theory

Lock-in amplifiers are instruments that measure the amplitude and phase of small signals that are buried in noise. Their basic operation is that of a very narrow bandpass filter centred on the frequency of interest. This frequency is specified through the use of a reference signal input to the instrument that is of exactly the same frequency as the signal of interest. The signal is extracted through the use of a demodulator or multiplier which multiplies the input signal with the reference signal. This has the effect of frequency shifting the signal of interest to DC. The noise signals can now be removed with a simple low pass filter. The output signal will be a DC signal proportional to $A \cdot \cos(\theta)$ where A is the amplitude of the input signal and θ is the phase relationship between the input signal and the reference. As θ may be non zero, a phase shifting circuit is included in the reference circuitry to enable the maximum signal size to be found.

3.2 Full Lock-in Amplifier Theory

For lock-in amplifier theory please visit a number of pages on the Internet produced by M. Stachel of Faculty of Physics University of Konstanz Germany. It is available at www.lockin.de and includes theory, diagrams and a virtual Java lock-in amplifier.

3.3 Circuit Description

3.3.1 Block Diagram

442 OEM Lock-in Amplifier Block Diagram

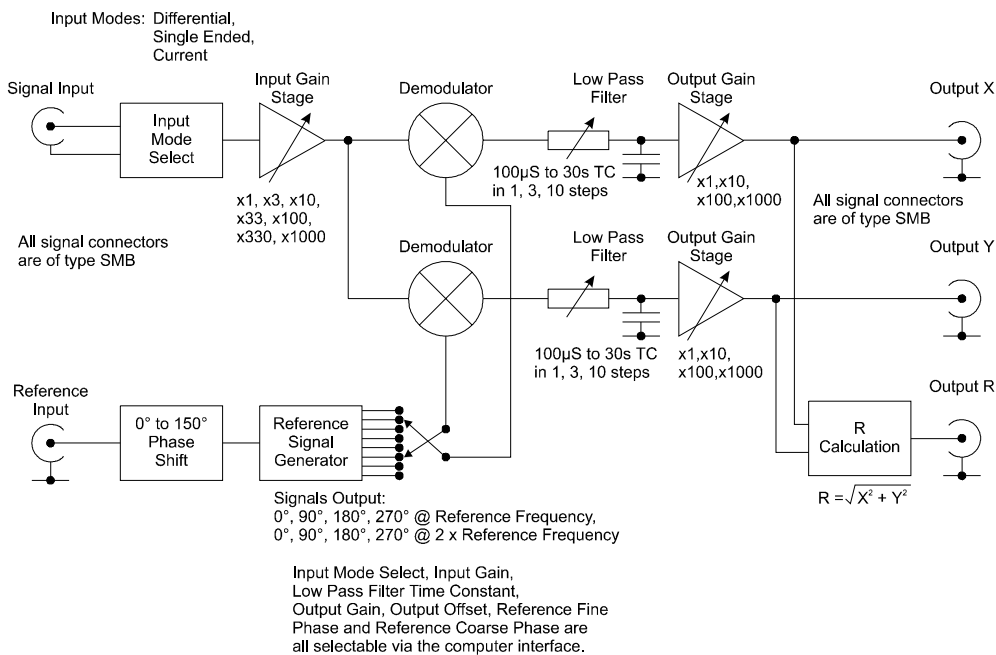

Figure 2 - 442 Block Diagram



Bartles Industrial Estate Tel: +44 (0)1209 314 608 scitec@scitec.uk.com
North Street, Redruth Fax: +44 (0)1209 314 609 www.scitec.uk.com
Cornwall TR15 1HR Fax2: +44 (0)870 1600 860

3.3.2 Input Mode Select

To allow flexibility in the type of sensors and signal sources that the 442 is connected to, there are a number of modes that the input stage can be set up as. These include AC and DC coupling of the input, single ended or differential input and a test mode.

If a DC offset is present at the input to the demodulator, then this offset is multiplied by the reference signal producing an output square wave at the reference frequency. This signal is unwanted so it is necessary to remove all DC offset from the input signal. The 442 lock-in amplifier uses two methods for the removal of this signal. The first method is to AC couple the input. This uses a simple resistor capacitor filter and can remove up to 40V of DC offset from the input. Unfortunately, the resistor used has a high value (6M Ω) and this can add a significant amount of thermal noise to the input signal. It is therefore recommended that the input stage is DC coupled rather than AC coupled.

If the input signal is DC coupled then any DC offset is removed after the first gain stage. This has the advantage that lower resistor values can be used (470k) and the effects of thermal noise of these resistors are reduced by the gain of the first stage. The draw back is that the size of DC offset that can be removed depends on the first stage gain as follows:

| Input Stage Gain | Maximum input signal + offset voltage allowed before clipping occurs when input is DC coupled |
|------------------|---|
| x1 | $\pm 13V$ |
| x3.3 | $\pm 13V$ |
| x10 | $\pm 1.3V$ |
| x33 | $\pm 1.3V$ |
| x100 | $\pm 130mV$ |
| x330 | $\pm 130mV$ |
| x1000 | $\pm 130mV$ |

It is often the case that input signals have little or no DC offset on the input signal. In these cases, simply DC couple the input stage. However, if the above limits are exceeded then the input will have to be AC coupled with the Resistor Capacitor filter.

There is often confusion as to how best to connect the signal grounds when connecting a sensor to a lock-in amplifier. The basic rule is that the ground should only be connected in one place. If the ground is connected in multiple places then earth loops can be produced which can cause noise to be inserted onto the signal being measured.

There are two main methods used: Connect the ground at the sensor or connect the ground at the lock-in. Examples of the possible connections are shown in Figure 3 and Figure 4. The choice between these two techniques is generally decided by which ever is easier to implement.



Details of the different modes and how to set the modes is shown in section 7.2.

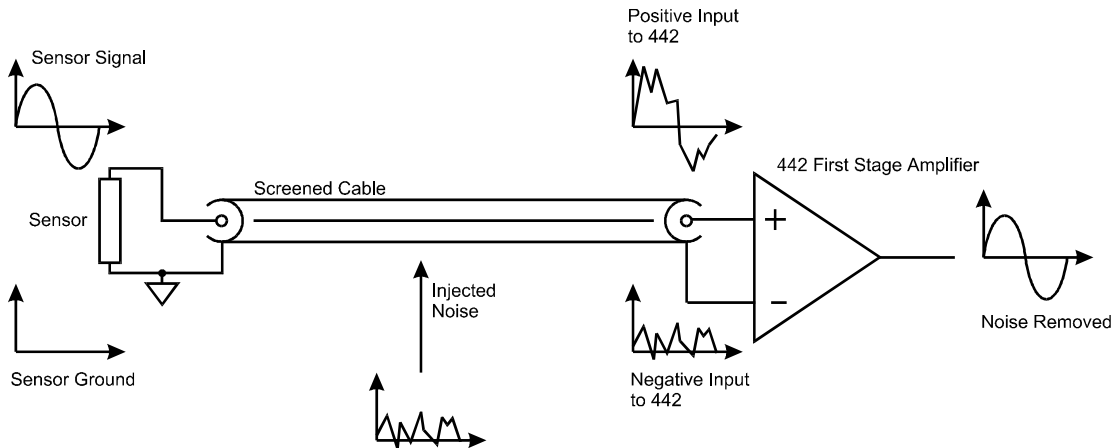

Figure 3 - Signal Ground Connected at Sensor

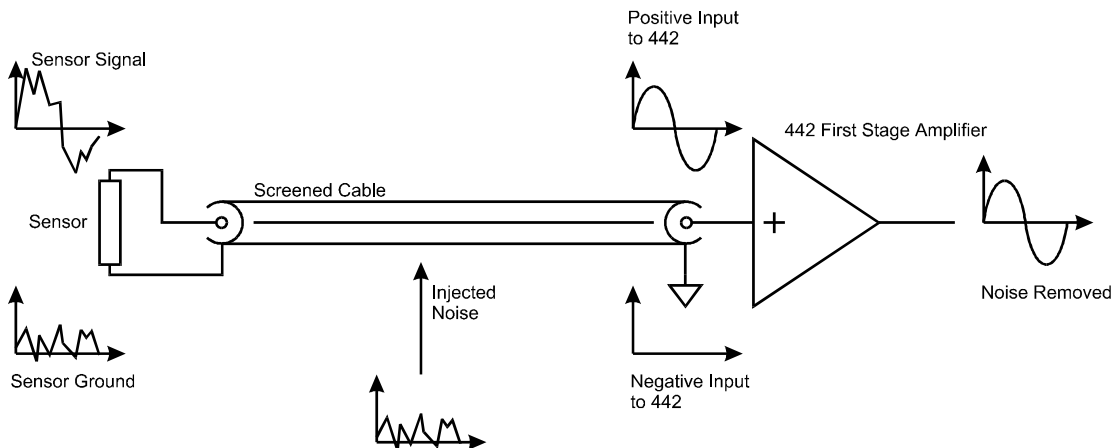

Figure 4 - Signal Ground Connected at Input to Lock-in

3.3.3 Input Stage Gain

In the 442 lock-in amplifier, there are two gain sections. One before the demodulator (Input Gain Stage) and one after the demodulator (Output Gain Stage). Both can be used to boost the input signal but it is generally best to put as much of the gain as possible in the input gain section. With low gain at the output, the offset drifts are kept to a minimum as this improves performance. Unfortunately, it also limits the dynamic reserve figure.

Full details on the input gain settings possible are given in section 7.2.

More details on gain settings and dynamic reserve are give in section 4.

3.3.4 Demodulator

The demodulator simply multiplies the input signal by either +1 or -1 dependant on the reference signal. This has the effect of shifting the



Bartles Industrial Estate Tel: +44 (0)1209 314 608 scitec@scitec.uk.com
North Street, Redruth Fax: +44 (0)1209 314 609 www.scitec.uk.com
Cornwall TR15 1HR Fax2: +44 (0)870 1600 860

signal at the reference frequency to DC. Please note that the 442 uses a square wave for demodulation which means that the signals at the third, fifth, etc harmonic of the reference signal are also converted to DC however their signal strength is attenuated by 1/3, 1/5, etc. Demodulation with a sinewave does not have this problem but suffers from greater output ripple, greater switching noise problems and is more complex.

3.3.5 Low Pass Filter

The low pass filter takes the output of the demodulator and removes the high frequency components. It is a simple first order filter with a response of that shown in Figure 5.

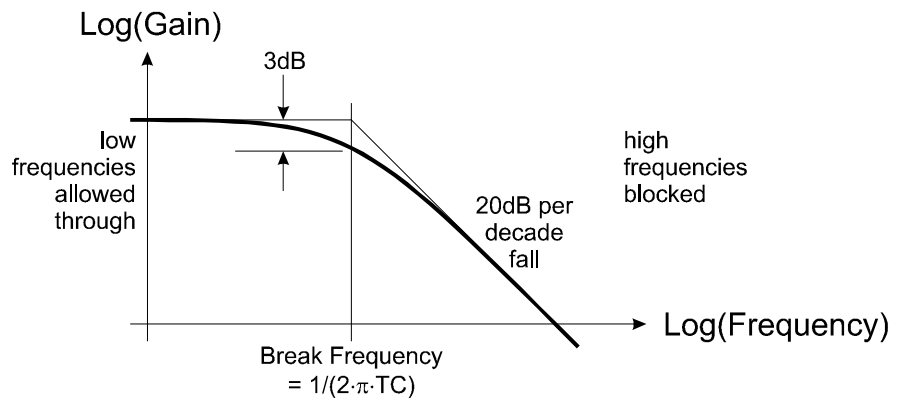

Figure 5 - Low Pass Filter Response

The break frequency of the filter is the point at which the output is attenuated by 3dB (29%). This point is related to the Time Constant value by the equation:

$$\text{Break Frequency} = 1/(2 \cdot \pi \cdot \text{Time Constant})$$

As an example, lets consider the following:

Frequency of signal of interest - 1000Hz

Time Constant - 100mS

Hence we can calculate the break frequency:

$$\text{Break Frequency} = 1/(2 \cdot 3.14 \cdot 0.1) = 1.6\text{Hz}$$

This means that the low pass filter will allow through signals from DC to 1.6Hz and will attenuate signals of frequencies higher than this.

Now the demodulator will have down shifted the 1000Hz input signal to DC and hence this will pass straight through the low pass filter. However, the signals either side of the 1000Hz signal will also have been down shifted to around DC so these signals will also pass through the low pass filter with minimum attenuation.

In the above example, input signals from 998.4Hz to 1001.6Hz will be demodulated to the band DC to 1.6Hz and will pass through the low pass filter. All other signals will be attenuated.



3.3.6

Output Stage Gain

The signals at the input to the low pass filter will, in general, contain a large amount of noise. The low pass filter will reject this noise reducing the overall size of the signal. This then enables the signal to be amplified without the danger of saturation or clipping.

It is important, however, to keep the output stage gain to the minimum possible and to amplify at the input stage instead. The reason for this that the output signal of interest is at DC. This means any offset errors in the analogue circuitry after the demodulator will be mixed with signal you are trying to measure. As the size of these instrumentation offset errors are directly related to the gain in the output stage lower gains means more accurate measurements.

As an example, lets consider the following:

Input signal of interest = 10 μ V AC rms

Noise on input signal = \pm 100mV Peak

Required output signal = 1V DC

Offset error at output of demodulator = \pm 100 μ V

Now the maximum gain we can set at the input stage is x100 as gains larger than this will cause the signal to clip.

Demodulator input signal of interest = 10 μ V x100 = 1mV AC rms

Demodulator input signal noise = \pm 100mV x 100 = \pm 10V Peak

The signal will then pass through the demodulator and low pass filter where the noise will be removed. However the offset error from the demodulator will be added.

Low pass filter output signal = 1mV \pm 100 μ V DC

To get the required 1V output signal now requires an output stage gain of x1000

Output from lock-in = 1mV \pm 100 μ V x1000 = 1V \pm 100mV DC

Fortunately, the offset error only changes slowly over time and can therefore be corrected for. This is why output offset adjustment circuitry is included on the 442 board.

More details on choosing gain settings are given in section 4.

3.3.7

Reference Circuitry

To indicate to the lock-in amplifier the frequency of the signal being measured, a reference signal is required. This signal can be sine, triangular, square wave with up to 50V DC offset or a TTL or CMOS signal. Only the rising edge of the signal is used by the reference circuitry.

The general output signal from the 442 lock-in amplifier will be a DC signal proportional to $A \cdot \cos(\theta)$ where A is the amplitude of the input signal and θ



Scitec Instruments Ltd

Bartles Industrial Estate Tel: +44 (0)1209 314 608 scitec@scitec.uk.com
North Street, Redruth Fax: +44 (0)1209 314 609 www.scitec.uk.com
Cornwall TR15 1HR Fax2: +44 (0)870 1600 860

is the phase relationship between the input signal and the reference. As θ may be non zero, a phase shifting circuitry is included in the reference circuitry to enable the maximum signal size to be found.

The phase shifting circuitry is split into a coarse phase adjust with 90° phase shifting steps and a fine phase adjust which covers the range 0 to 150° in 256 steps.

As the phase shifting circuitry is the limiting factor to the frequency range of operation of the instrument, both sections can be bypassed if required. This will then enable operation below 10Hz and above 100kHz. If the coarse phase shift is bypassed, it is important that the input reference signal has an exact 1:1 mark to space ratio as any discrepancy will cause errors at the output.

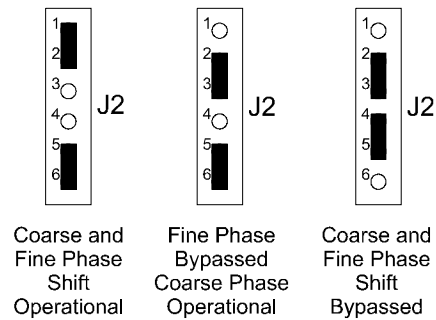

Figure 6 - Coarse and Fine Phase Shift Bypass Options

Please note that the Fine Phase circuitry is the same for both the X and the Y channel. This means that the Fine Phase bypass will bypass the both the X and Y channel. However, there are separate coarse phase shifts for the X and Y channels and the bypass only operates for the X channel. See Figure 7.

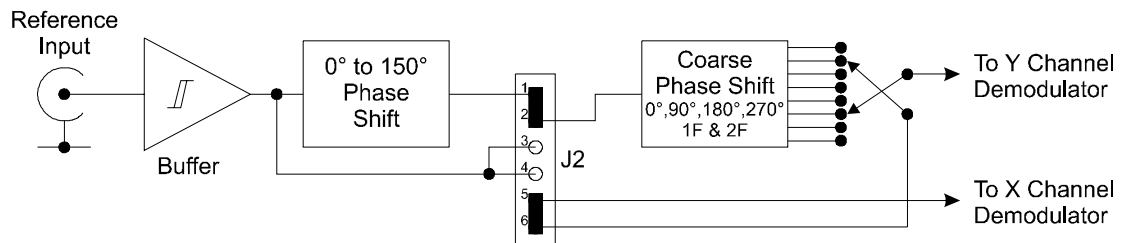

Figure 7 - Phase Shifting Bypass Circuitry

Details on how to set the different fine and coarse phase settings are given in section 7.1 & 7.4.



4

OVERALL SYSTEM GAIN AND DYNAMIC RESERVE

To get the best performance out of the lock-in amplifier card, it is important that the gain settings at the input and at the output are correctly balanced to give optimum performance.

A high gain at the input and a low gain at the output improves noise performance and offset drift. A low gain at the input and a high gain at the output gives a high dynamic reserve at the cost of noise and offset performance.

The first stage in achieving optimum performance is to understand the features of the input signal fed into the lock-in. The different sections are shown in Figure 8.

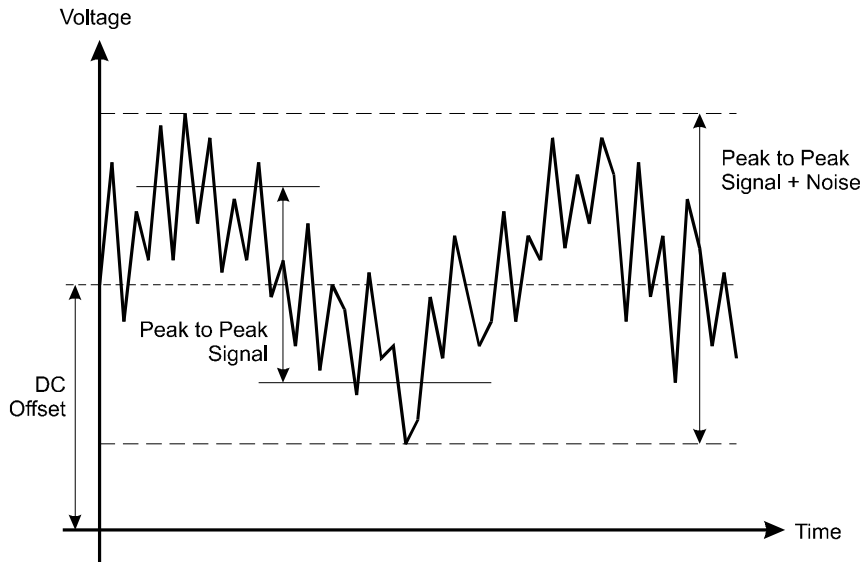

Figure 8 - Input Signal

The input wave form is generally made up from 3 components. They are:

- A sine wave (or similar) at the reference frequency
- Noise at either higher or low frequencies (or both)
- A DC offset

If the DC offset is within the limits specified in Section 3.3.2 then it can be ignored. If it is greater than this then it is necessary to AC couple the input, to remove the offset as specified in Section 7.2.

4.1

Dynamic Reserve

The dynamic reserve of the system is defined as the ratio of the noise to signal that is allowed within the system before saturation occurs, specified in dBs.



Scitec Instruments Ltd

Bartles Industrial Estate Tel: +44 (0)1209 314 608 scitec@scitec.uk.com
North Street, Redruth Fax: +44 (0)1209 314 609 www.scitec.uk.com
Cornwall TR15 1HR Fax2: +44 (0)870 1600 860

A dynamic reserve of 20dB means that the noise can be a factor of 10 larger than the signal before saturation occurs.

A dynamic reserve of 40dB means that the noise can be a factor of 100 larger than the signal before saturation occurs.

A dynamic reserve of 60dB means that the signal can be a factor of 1000 larger than the signal before saturation occurs.

A dynamic reserve of 80dB means that the signal can be a factor of 10000 larger than the signal before saturation occurs.

Normally the signal and noise values used to calculate dynamic reserve are RMS measurements. The following explanation will use the Peak to Peak values as this is easier to understand and works for all types of noise not just white noise.

4.2

Maximum Signal Size Up To The Low Pass Filter

Assuming that the lock-in amplifier board is operating from $\pm 15V$, the maximum Peak to Peak Signal + Noise amplitude allowed before saturation occurs is 26V. This applies at all stages up to the input to the Low Pass Filter.

For example, if the input signal fed into the board has a Peak to Peak Signal + Noise value of 100mV, then the maximum gain possible at the input stage is 260. If a higher gain than this is required, then it is necessary to include this additional gain at the output stage. A table of gains and maximum input signal allowed is given below:

| Total Input Stage Gain | Maximum Peak to Peak Signal + Noise Input Allowed Before Saturation Occurs |
|------------------------|--|
| x 1 | 26V |
| x 3.33 | 7.8V |
| x 10 | 2.6V |
| x 33.3 | 780mV |
| x 100 | 260mV |
| x 333 | 78mV |

Please note that the maximum gain at the input is not dependant on the amplitude of the signal you are trying to measure. The maximum gain at the input is only dependant on the amplitude of the signal + noise.

4.3

Maximum Signal Size From Low Pass Filter to Output

Once the demodulated signal has passed through the low pass filter, the noise on the signal will be reduced. This reduces the Peak to Peak Signal + Noise amplitude and allows further gain to be included in the output stage. The maximum size of gain at the output depends on the amplitude and bandwidth of the noise and also on the time constant of the low pass filter. Generally, a larger time constant will reduce the noise more allowing a greater output gain to be used.



4.4 Example Gain Settings

The following is a list of example settings for various input signal and noise levels. This is not an exhaustive list.

| Input Signal Level | | Input Noise | Input Noise + Signal | Maximum Input Gain Setting | Actual Input Gain Setting | Output Gain Setting | Total System Gain | Output Voltage |
|--------------------|---------|-------------|----------------------|----------------------------|---------------------------|---------------------|-------------------|----------------|
| RMS | P to P | P to P | P to P | | | | | DC |
| 1 V | 2.82 V | 0 V | 2.82 V | x 9.21 | x 1 | x 1 | x 1 | 1 V |
| 1 V | 2.82 V | 0 V | 2.82 V | x 9.21 | x 3.33 | x 1 | x 3.33 | 3.33 V |
| 1 V | 2.82 V | 0 V | 2.82 V | x 9.21 | x 1 | x 10 | x 10 | 10 V |
| 1 V | 2.82 V | 20 V | 22.82 V | x 1.14 | x 1 | x 1 | x 1 | 1 V |
| 1 V | 2.82 V | 4 V | 6.82 V | x 3.81 | x 3.33 | x 1 | x 3.33 | 3.33 V |
| 1 V | 2.82 V | 20 V | 22.82 V | x 1.14 | x 1 | x 10 | x 10 | 10 V |
| 300 mV | 848 mV | 0 V | 848 mV | x 30.6 | x 1 | x 1 | x 1 | 300 mV |
| 300 mV | 848 mV | 0 V | 848 mV | x 30.6 | x 3.33 | x 1 | x 3.33 | 1 V |
| 300 mV | 848 mV | 0 V | 848 mV | x 30.6 | x 10 | x 1 | x 10 | 3 V |
| 300 mV | 848 mV | 0 V | 848 mV | x 30.6 | x 3.33 | x 10 | x 33.3 | 10 V |
| 300 mV | 848 mV | 20 V | 20.9 V | x 1.24 | x 1 | x 1 | x 1 | 300 mV |
| 300 mV | 848 mV | 6 V | 6.85 V | x 3.80 | x 3.33 | x 1 | x 3.33 | 1 V |
| 300 mV | 848 mV | 2 V | 2.85 V | x 9.12 | x 10 | x 1 | x 10 | 3 V |
| 300 mV | 848 mV | 6 V | 6.85 V | x 3.80 | x 3.33 | x 10 | x 33.3 | 10 V |
| 100 mV | 282 mV | 0 V | 282 mV | x 92.2 | x 1 | x 1 | x 1 | 100 mV |
| 100 mV | 282 mV | 0 V | 282 mV | x 92.2 | x 3.33 | x 1 | x 3.33 | 333 mV |
| 100 mV | 282 mV | 0 V | 282 mV | x 92.2 | x 10 | x 1 | x 10 | 1 V |
| 100 mV | 282 mV | 0 V | 282 mV | x 92.2 | x 33.3 | x 1 | x 33.3 | 3.33 V |
| 100 mV | 282 mV | 0 V | 282 mV | x 92.2 | x 10 | x 10 | x 100 | 10 V |
| 100 mV | 282 mV | 20 V | 20.3 V | x 1.28 | x 1 | x 1 | x 1 | 100 mV |
| 100 mV | 282 mV | 7 V | 7.28 V | x 3.56 | x 3.33 | x 1 | x 3.33 | 333 mV |
| 100 mV | 282 mV | 2 V | 2.28 V | x 11.4 | x 10 | x 1 | x 10 | 1 V |
| 100 mV | 282 mV | 400 mV | 682 mV | x 38.1 | x 33.3 | x 1 | x 33.3 | 3.33 V |
| 30 mV | 84.8 mV | 0V | 84.8 mV | x 306 | x 1 | x 1 | x 1 | 30 mV |
| 30 mV | 84.8 mV | 0V | 84.8 mV | x 306 | x 3.33 | x 1 | x 3.33 | 100 mV |
| 30 mV | 84.8 mV | 0V | 84.8 mV | x 306 | x 10 | x 1 | x 10 | 300 mV |
| 30 mV | 84.8 mV | 0V | 84.8 mV | x 306 | x 33.3 | x 1 | x 33.3 | 1 V |
| 30 mV | 84.8 mV | 0V | 84.8 mV | x 306 | x 100 | x 1 | x 100 | 3 V |
| 30 mV | 84.8 mV | 0V | 84.8 mV | x 306 | x 33.3 | x 10 | x 333 | 10 V |
| 30 mV | 84.8 mV | 0V | 84.8 mV | x 306 | x 3.33 | x 100 | x 333 | 10 V |
| 30 mV | 84.8 mV | 20V | 20V | x 1.3 | x 1 | x 1 | x 1 | 30 mV |
| 30 mV | 84.8 mV | 7V | 7.08 V | x 3.67 | x 3.33 | x 1 | x 3.33 | 100 mV |
| 30 mV | 84.8 mV | 2V | 2.08 V | x 12.5 | x 10 | x 1 | x 10 | 300 mV |
| 30 mV | 84.8 mV | 600 mV | 685 mV | x 38.0 | x 33.3 | x 1 | x 33.3 | 1 V |
| 30 mV | 84.8 mV | 100 mV | 185 mV | x 141 | x 100 | x 1 | x 100 | 3 V |
| 30 mV | 84.8 mV | 600 mV | 84.8 mV | x 38.0 | x 33.3 | x 10 | x 333 | 10 V |
| 30 mV | 84.8 mV | 7 V | 7.08 V | x 3.67 | x 3.33 | x 100 | x 333 | 10 V |
| 10 mV | 28.2 mV | 0 V | 28.2 mV | x 922 | x 1 | x 1 | x 1 | 10 mV |
| 10 mV | 28.2 mV | 0 V | 28.2 mV | x 922 | x 3.33 | x 1 | x 3.33 | 33.3 mV |
| 10 mV | 28.2 mV | 0 V | 28.2 mV | x 922 | x 10 | x 1 | x 10 | 100 mV |
| 10 mV | 28.2 mV | 0 V | 28.2 mV | x 922 | x 33.3 | x 1 | x 33.3 | 333 mV |
| 10 mV | 28.2 mV | 0 V | 28.2 mV | x 922 | x 100 | x 1 | x 100 | 1 V |
| 10 mV | 28.2 mV | 0 V | 28.2 mV | x 922 | x 333 | x 1 | x 333 | 3.33 V |
| 10 mV | 28.2 mV | 0 V | 28.2 mV | x 922 | x 100 | x 10 | x 1000 | 10 V |
| 10 mV | 28.2 mV | 0 V | 28.2 mV | x 922 | x 10 | x 100 | x 1000 | 10 V |
| 10 mV | 28.2 mV | 0 V | 28.2 mV | x 922 | x 1 | x 1000 | x 1000 | 10 V |
| 10 mV | 28.2 mV | 20 V | 20 V | x 1.3 | x 1 | x 1 | x 1 | 10 mV |
| 10 mV | 28.2 mV | 7 V | 7.02 V | x 3.7 | x 3.33 | x 1 | x 3.33 | 33.3 mV |
| 10 mV | 28.2 mV | 2 V | 2.02V | x 12.9 | x 10 | x 1 | x 10 | 100 mV |
| 10 mV | 28.2 mV | 700 mV | 728 mV | x 35.7 | x 33.3 | x 1 | x 33.3 | 333 mV |
| 10 mV | 28.2 mV | 200 mV | 228 mV | x 114 | x 100 | x 1 | x 100 | 1 V |
| 10 mV | 28.2 mV | 40 mV | 68.2 mV | x 381 | x 333 | x 1 | x 333 | 3.33 V |
| 10 mV | 28.2 mV | 200 mV | 228 mV | x 114 | x 100 | x 10 | x 1000 | 10 V |



Scitec Instruments Ltd

Bartles Industrial Estate Tel: +44 (0)1209 314 608 scitec@scitec.uk.com
 North Street, Redruth Fax: +44 (0)1209 314 609 www.scitec.uk.com
 Cornwall TR15 1HR Fax2: +44 (0)870 1600 860

| Input Signal Level | | Input Noise | Input Noise + Signal | Maximum Input Gain Setting | Actual Input Gain Setting | Output Gain Setting | Total System Gain | Output Voltage |
|--------------------|---------|-------------|----------------------|----------------------------|---------------------------|---------------------|-------------------|----------------|
| RMS | P to P | P to P | P to P | | | | | DC |
| 10 mV | 28.2 mV | 2 V | 2.02 V | x 12.9 | x 10 | x 100 | x 1000 | 10 V |
| 10 mV | 28.2 mV | 20 V | 20 V | x 1.3 | x 1 | x 1000 | x 1000 | 10 V |
| 3 mV | 8.48 mV | 0 V | 8.48 mV | x 3070 | x 1 | x 1 | x 1 | 3 mV |
| 3 mV | 8.48 mV | 0 V | 8.48 mV | x 3070 | x 3.33 | x 1 | x 3.33 | 10 mV |
| 3 mV | 8.48 mV | 0 V | 8.48 mV | x 3070 | x 10 | x 1 | x 10 | 30 mV |
| 3 mV | 8.48 mV | 0 V | 8.48 mV | x 3070 | x 33.3 | x 1 | x 33.3 | 100 mV |
| 3 mV | 8.48 mV | 0 V | 8.48 mV | x 3070 | x 100 | x 1 | x 100 | 300 mV |
| 3 mV | 8.48 mV | 0 V | 8.48 mV | x 3070 | x 333 | x 1 | x 333 | 1 V |
| 3 mV | 8.48 mV | 0 V | 8.48 mV | x 3070 | x 100 | x 10 | x 1000 | 3 V |
| 3 mV | 8.48 mV | 0 V | 8.48 mV | x 3070 | x 333 | x 10 | x 3330 | 10 V |
| 3 mV | 8.48 mV | 0 V | 8.48 mV | x 3070 | x 33.3 | x 100 | x 3330 | 10 V |
| 3 mV | 8.48 mV | 0 V | 8.48 mV | x 3070 | x 3.33 | x 1000 | x 3330 | 10 V |
| 3 mV | 8.48 mV | 20 V | 20 V | x 1.3 | x 1 | x 1 | x 1 | 3 mV |
| 3 mV | 8.48 mV | 7 V | 7 V | x 3.7 | x 3.33 | x 1 | x 3.33 | 10 mV |
| 3 mV | 8.48 mV | 2 V | 2 V | x 13 | x 10 | x 1 | x 10 | 30 mV |
| 3 mV | 8.48 mV | 700 mV | 708 mV | x 36.7 | x 33.3 | x 1 | x 33.3 | 100 mV |
| 3 mV | 8.48 mV | 200 mV | 208 mV | x 125 | x 100 | x 1 | x 100 | 300 mV |
| 3 mV | 8.48 mV | 60 mV | 68.5 mV | x 380 | x 333 | x 1 | x 333 | 1 V |
| 3 mV | 8.48 mV | 200 mV | 208 mV | x 125 | x 100 | x 10 | x 1000 | 3 V |
| 3 mV | 8.48 mV | 60 mV | 68.5 mV | x 380 | x 333 | x 10 | x 3330 | 10 V |
| 3 mV | 8.48 mV | 700 mV | 708 mV | x 36.7 | x 33.3 | x 100 | x 3330 | 10 V |
| 3 mV | 8.48 mV | 7 V | 7 V | x 3.7 | x 3.33 | x 1000 | x 3330 | 10 V |
| 1 mV | 2.82 mV | 0 V | 2.82 mV | x 9220 | x 1 | x 1 | x 1 | 1 mV |
| 1 mV | 2.82 mV | 0 V | 2.82 mV | x 9220 | x 3.33 | x 1 | x 3.33 | 3.33 mV |
| 1 mV | 2.82 mV | 0 V | 2.82 mV | x 9220 | x 10 | x 1 | x 10 | 10 mV |
| 1 mV | 2.82 mV | 0 V | 2.82 mV | x 9220 | x 33.3 | x 1 | x 33.3 | 33.3 mV |
| 1 mV | 2.82 mV | 0 V | 2.82 mV | x 9220 | x 100 | x 1 | x 100 | 100 mV |
| 1 mV | 2.82 mV | 0 V | 2.82 mV | x 9220 | x 333 | x 1 | x 333 | 333 mV |
| 1 mV | 2.82 mV | 0 V | 2.82 mV | x 9220 | x 100 | x 10 | x 1000 | 1 V |
| 1 mV | 2.82 mV | 0 V | 2.82 mV | x 9220 | x 333 | x 10 | x 3330 | 3.33 V |
| 1 mV | 2.82 mV | 0 V | 2.82 mV | x 9220 | x 100 | x 100 | x 10000 | 10 V |
| 1 mV | 2.82 mV | 0 V | 2.82 mV | x 9220 | x 10 | x 1000 | x 10000 | 10 V |
| 1 mV | 2.82 mV | 20 V | 20 V | x 1.3 | x 1 | x 1 | x 1 | 1 mV |
| 1 mV | 2.82 mV | 7 V | 7 V | x 3.7 | x 3.33 | x 1 | x 3.33 | 3.33 mV |
| 1 mV | 2.82 mV | 2 V | 2 V | x 13 | x 10 | x 1 | x 10 | 10 mV |
| 1 mV | 2.82 mV | 700 mV | 703 mV | x 37.0 | x 33.3 | x 1 | x 33.3 | 33.3 mV |
| 1 mV | 2.82 mV | 200 mV | 203 mV | x 128 | x 100 | x 1 | x 100 | 100 mV |
| 1 mV | 2.82 mV | 70 mV | 72.8 mV | x 357 | x 333 | x 1 | x 333 | 333 mV |
| 1 mV | 2.82 mV | 200 mV | 203 mV | x 128 | x 100 | x 10 | x 1000 | 1 V |
| 1 mV | 2.82 mV | 70 mV | 72.8 mV | x 357 | x 333 | x 10 | x 3330 | 3.33 V |
| 1 mV | 2.82 mV | 200 mV | 203 mV | x 128 | x 100 | x 100 | x 10000 | 10 V |
| 1 mV | 2.82 mV | 2 V | 2 V | x 13 | x 10 | x 1000 | x 10000 | 10 V |
| 300 µV | 848 µV | 0 V | 848 µV | x 30700 | x 1 | x 1 | x 1 | 300 µV |
| 300 µV | 848 µV | 0 V | 848 µV | x 30700 | x 3.33 | x 1 | x 3.33 | 1 mV |
| 300 µV | 848 µV | 0 V | 848 µV | x 30700 | x 10 | x 1 | x 10 | 3.33 mV |
| 300 µV | 848 µV | 0 V | 848 µV | x 30700 | x 33.3 | x 1 | x 33.3 | 10 mV |
| 300 µV | 848 µV | 0 V | 848 µV | x 30700 | x 100 | x 1 | x 100 | 33.3 mV |
| 300 µV | 848 µV | 0 V | 848 µV | x 30700 | x 333 | x 1 | x 333 | 100 mV |
| 300 µV | 848 µV | 0 V | 848 µV | x 30700 | x 100 | x 10 | x 1000 | 333 mV |
| 300 µV | 848 µV | 0 V | 848 µV | x 30700 | x 333 | x 10 | x 3330 | 1 V |
| 300 µV | 848 µV | 0 V | 848 µV | x 30700 | x 100 | x 100 | x 10000 | 3.33 V |
| 300 µV | 848 µV | 0 V | 848 µV | x 30700 | x 333 | x 100 | x 33300 | 10 V |
| 300 µV | 848 µV | 0 V | 848 µV | x 30700 | x 33.3 | x 1000 | x 33300 | 10 V |
| 300 µV | 848 µV | 20 V | 20 V | x 1.3 | x 1 | x 1 | x 1 | 300 µV |
| 300 µV | 848 µV | 7 V | 7 V | x 3.7 | x 3.33 | x 1 | x 3.33 | 1 mV |
| 300 µV | 848 µV | 2 V | 2 V | x 13 | x 10 | x 1 | x 10 | 3 mV |
| 300 µV | 848 µV | 700 mV | 700 mV | x 37.0 | x 33.3 | x 1 | x 33.3 | 10 mV |
| 300 µV | 848 µV | 200 mV | 200 mV | x 128 | x 100 | x 1 | x 100 | 30 mV |



Scitec Instruments Ltd

Bartles Industrial Estate Tel: +44 (0)1209 314 608 scitec@scitec.uk.com
 North Street, Redruth Fax: +44 (0)1209 314 609 www.scitec.uk.com
 Cornwall TR15 1HR Fax2: +44 (0)870 1600 860

| Input Signal Level | | Input Noise | Input Noise + Signal | Maximum Input Gain Setting | Actual Input Gain Setting | Output Gain Setting | Total System Gain | Output Voltage |
|--------------------|---------|-------------|----------------------|----------------------------|---------------------------|---------------------|-------------------|----------------|
| RMS | P to P | P to P | P to P | | | | | DC |
| 300 µV | 848 µV | 70 mV | 70.8 mV | x 367 | x 333 | x 1 | x 333 | 100 mV |
| 300 µV | 848 µV | 200 mV | 200 mV | x 128 | x 100 | x 10 | x 1000 | 300 mV |
| 300 µV | 848 µV | 70 mV | 70.8 mV | x 367 | x 333 | x 10 | x 3330 | 1 V |
| 300 µV | 848 µV | 200 mV | 200 mV | x 128 | x 100 | x 100 | x 10000 | 3 V |
| 300 µV | 848 µV | 70 mV | 70.8 mV | x 367 | x 333 | x 100 | x 33300 | 10 V |
| 300 µV | 848 µV | 700 mV | 700 mV | x 37.0 | x 33.3 | x 1000 | x 33300 | 10 V |
| 100 µV | 282 µV | 0V | 282 µV | x 92200 | x 1 | x 1 | x 1 | 100 µV |
| 100 µV | 282 µV | 0V | 282 µV | x 92200 | x 3.33 | x 1 | x 3.33 | 333 µV |
| 100 µV | 282 µV | 0V | 282 µV | x 92200 | x 10 | x 1 | x 10 | 1 mV |
| 100 µV | 282 µV | 0V | 282 µV | x 92200 | x 33.3 | x 1 | x 33.3 | 3.33 mV |
| 100 µV | 282 µV | 0V | 282 µV | x 92200 | x 100 | x 1 | x 100 | 10 mV |
| 100 µV | 282 µV | 0V | 282 µV | x 92200 | x 333 | x 1 | x 333 | 33.3 mV |
| 100 µV | 282 µV | 0V | 282 µV | x 92200 | x 100 | x 10 | x 1000 | 100 mV |
| 100 µV | 282 µV | 0V | 282 µV | x 92200 | x 333 | x 10 | x 3330 | 333 mV |
| 100 µV | 282 µV | 0V | 282 µV | x 92200 | x 100 | x 100 | x 10000 | 1 V |
| 100 µV | 282 µV | 0V | 282 µV | x 92200 | x 333 | x 100 | x 33300 | 3.33 V |
| 100 µV | 282 µV | 0V | 282 µV | x 92200 | x 100 | x 1000 | x 100000 | 10 V |
| 100 µV | 282 µV | 20 V | 20 V | x 1.3 | x 1 | x 1 | x 1 | 100 µV |
| 100 µV | 282 µV | 7 V | 7 V | x 3.7 | x 3.33 | x 1 | x 3.33 | 333 µV |
| 100 µV | 282 µV | 2 V | 2 V | x 13 | x 10 | x 1 | x 10 | 1 mV |
| 100 µV | 282 µV | 700 mV | 700 mV | x 37.0 | x 33.3 | x 1 | x 33.3 | 3.33 mV |
| 100 µV | 282 µV | 200 mV | 200 mV | x 128 | x 100 | x 1 | x 100 | 10 mV |
| 100 µV | 282 µV | 70 mV | 70.3 mV | x 370 | x 333 | x 1 | x 333 | 33.3 mV |
| 100 µV | 282 µV | 200 mV | 200 mV | x 128 | x 100 | x 10 | x 1000 | 100 mV |
| 100 µV | 282 µV | 70 mV | 70.3 mV | x 370 | x 333 | x 10 | x 3330 | 333 mV |
| 100 µV | 282 µV | 200 mV | 200 mV | x 128 | x 100 | x 100 | x 10000 | 1 V |
| 100 µV | 282 µV | 70 mV | 70.3 mV | x 370 | x 333 | x 100 | x 33300 | 3.33 V |
| 100 µV | 282 µV | 200 mV | 200 mV | x 128 | x 100 | x 1000 | x 100000 | 10 V |
| 30 µV | 84.8 µV | 0 V | 84.8 µV | x 307000 | x 1 | x 1 | x 1 | 30 µV |
| 30 µV | 84.8 µV | 0 V | 84.8 µV | x 307000 | x 3.33 | x 1 | x 3.33 | 100 µV |
| 30 µV | 84.8 µV | 0 V | 84.8 µV | x 307000 | x 10 | x 1 | x 10 | 333 µV |
| 30 µV | 84.8 µV | 0 V | 84.8 µV | x 307000 | x 33.3 | x 1 | x 33.3 | 1 mV |
| 30 µV | 84.8 µV | 0 V | 84.8 µV | x 307000 | x 100 | x 1 | x 100 | 3.33 mV |
| 30 µV | 84.8 µV | 0 V | 84.8 µV | x 307000 | x 333 | x 1 | x 333 | 10 mV |
| 30 µV | 84.8 µV | 0 V | 84.8 µV | x 307000 | x 100 | x 10 | x 1000 | 33.3 mV |
| 30 µV | 84.8 µV | 0 V | 84.8 µV | x 307000 | x 333 | x 10 | x 3330 | 100 mV |
| 30 µV | 84.8 µV | 0 V | 84.8 µV | x 307000 | x 100 | x 100 | x 10000 | 333 mV |
| 30 µV | 84.8 µV | 0 V | 84.8 µV | x 307000 | x 333 | x 100 | x 33300 | 1 V |
| 30 µV | 84.8 µV | 0 V | 84.8 µV | x 307000 | x 100 | x 1000 | x 100000 | 3.33 V |
| 30 µV | 84.8 µV | 0 V | 84.8 µV | x 307000 | x 333 | x 1000 | x 333000 | 10 V |
| 30 µV | 84.8 µV | 20 V | 20 V | x 1.3 | x 1 | x 1 | x 1 | 30 µV |
| 30 µV | 84.8 µV | 7 V | 7 V | x 3.7 | x 3.33 | x 1 | x 3.33 | 100 µV |
| 30 µV | 84.8 µV | 2 V | 2 V | x 13 | x 10 | x 1 | x 10 | 300 µV |
| 30 µV | 84.8 µV | 700 mV | 700 mV | x 37.0 | x 33.3 | x 1 | x 33.3 | 1 mV |
| 30 µV | 84.8 µV | 200 mV | 200 mV | x 128 | x 100 | x 1 | x 100 | 3 mV |
| 30 µV | 84.8 µV | 70 mV | 70 mV | x 370 | x 333 | x 1 | x 333 | 10 mV |
| 30 µV | 84.8 µV | 200 mV | 200 mV | x 128 | x 100 | x 10 | x 1000 | 30 mV |
| 30 µV | 84.8 µV | 70 mV | 70 mV | x 370 | x 333 | x 10 | x 3330 | 100 mV |
| 30 µV | 84.8 µV | 200 mV | 200 mV | x 128 | x 100 | x 100 | x 10000 | 300 mV |
| 30 µV | 84.8 µV | 70 mV | 70 mV | x 370 | x 333 | x 100 | x 33300 | 1 V |
| 30 µV | 84.8 µV | 200 mV | 200 mV | x 128 | x 100 | x 1000 | x 100000 | 3 V |
| 30 µV | 84.8 µV | 70 mV | 70 mV | x 370 | x 333 | x 1000 | x 333000 | 10 V |
| 10 µV | 28.2 µV | 0 V | 28.2 µV | x 922000 | x 1 | x 1 | x 1 | 10 µV |
| 10 µV | 28.2 µV | 0 V | 28.2 µV | x 922000 | x 3.33 | x 1 | x 3.33 | 33.3 µV |
| 10 µV | 28.2 µV | 0 V | 28.2 µV | x 922000 | x 10 | x 1 | x 10 | 100 µV |
| 10 µV | 28.2 µV | 0 V | 28.2 µV | x 922000 | x 33.3 | x 1 | x 33.3 | 333 µV |
| 10 µV | 28.2 µV | 0 V | 28.2 µV | x 922000 | x 100 | x 1 | x 100 | 1 mV |
| 10 µV | 28.2 µV | 0 V | 28.2 µV | x 922000 | x 333 | x 1 | x 333 | 3.33 mV |



Scitec Instruments Ltd

Bartles Industrial Estate Tel: +44 (0)1209 314 608 scitec@scitec.uk.com
 North Street, Redruth Fax: +44 (0)1209 314 609 www.scitec.uk.com
 Cornwall TR15 1HR Fax2: +44 (0)870 1600 860

| Input Signal Level | | Input Noise | Input Noise + Signal | Maximum Input Gain Setting | Actual Input Gain Setting | Output Gain Setting | Total System Gain | Output Voltage |
|--------------------|---------|-------------|----------------------|----------------------------|---------------------------|---------------------|-------------------|----------------|
| RMS | P to P | P to P | P to P | | | | | DC |
| 10 µV | 28.2 µV | 0 V | 28.2 µV | x 922000 | x 100 | x 10 | x 1000 | 10 mV |
| 10 µV | 28.2 µV | 0 V | 28.2 µV | x 922000 | x 333 | x 10 | x 3330 | 33.3 mV |
| 10 µV | 28.2 µV | 0 V | 28.2 µV | x 922000 | x 100 | x 100 | x 10000 | 100 mV |
| 10 µV | 28.2 µV | 0 V | 28.2 µV | x 922000 | x 333 | x 100 | x 33300 | 333 mV |
| 10 µV | 28.2 µV | 0 V | 28.2 µV | x 922000 | x 100 | x 1000 | x 100000 | 1 V |
| 10 µV | 28.2 µV | 0 V | 28.2 µV | x 922000 | x 333 | x 1000 | x 333000 | 3.33 V |
| 10 µV | 28.2 µV | 20 V | 20 V | x 1.3 | x 1 | x 1 | x 1 | 10 µV |
| 10 µV | 28.2 µV | 7 V | 7 V | x 3.7 | x 3.33 | x 1 | x 3.33 | 33.3 µV |
| 10 µV | 28.2 µV | 2 V | 2 V | x 13 | x 10 | x 1 | x 10 | 100 µV |
| 10 µV | 28.2 µV | 700 mV | 700 mV | x 37.0 | x 33.3 | x 1 | x 33.3 | 333 µV |
| 10 µV | 28.2 µV | 200 mV | 200 mV | x 128 | x 100 | x 1 | x 100 | 1 mV |
| 10 µV | 28.2 µV | 70 mV | 70 mV | x 370 | x 333 | x 1 | x 333 | 3.33 mV |
| 10 µV | 28.2 µV | 200 mV | 200 mV | x 128 | x 100 | x 10 | x 1000 | 10 mV |
| 10 µV | 28.2 µV | 70 mV | 70 mV | x 370 | x 333 | x 10 | x 3330 | 33.3 mV |
| 10 µV | 28.2 µV | 200 mV | 200 mV | x 128 | x 100 | x 100 | x 10000 | 100 mV |
| 10 µV | 28.2 µV | 70 mV | 70 mV | x 370 | x 333 | x 100 | x 33300 | 333 mV |
| 10 µV | 28.2 µV | 200 mV | 200 mV | x 128 | x 100 | x 1000 | x 100000 | 1 V |
| 10 µV | 28.2 µV | 70 mV | 70 mV | x 370 | x 333 | x 1000 | x 333000 | 3.33 V |
| 3 µV | 8.48 µV | 0 V | 8.48 µV | x 3070000 | x 1 | x 1 | x 1 | 3 µV |
| 3 µV | 8.48 µV | 0 V | 8.48 µV | x 3070000 | x 3.33 | x 1 | x 3.33 | 10 µV |
| 3 µV | 8.48 µV | 0 V | 8.48 µV | x 3070000 | x 10 | x 1 | x 10 | 30 µV |
| 3 µV | 8.48 µV | 0 V | 8.48 µV | x 3070000 | x 33.3 | x 1 | x 33.3 | 100 µV |
| 3 µV | 8.48 µV | 0 V | 8.48 µV | x 3070000 | x 100 | x 1 | x 100 | 300 µV |
| 3 µV | 8.48 µV | 0 V | 8.48 µV | x 3070000 | x 333 | x 1 | x 333 | 1 mV |
| 3 µV | 8.48 µV | 0 V | 8.48 µV | x 3070000 | x 100 | x 10 | x 1000 | 3 mV |
| 3 µV | 8.48 µV | 0 V | 8.48 µV | x 3070000 | x 333 | x 10 | x 3330 | 10 mV |
| 3 µV | 8.48 µV | 0 V | 8.48 µV | x 3070000 | x 100 | x 100 | x 10000 | 30 mV |
| 3 µV | 8.48 µV | 0 V | 8.48 µV | x 3070000 | x 333 | x 100 | x 33300 | 100 mV |
| 3 µV | 8.48 µV | 0 V | 8.48 µV | x 3070000 | x 100 | x 1000 | x 100000 | 300 mV |
| 3 µV | 8.48 µV | 0 V | 8.48 µV | x 3070000 | x 333 | x 1000 | x 333000 | 1 V |
| 3 µV | 8.48 µV | 20 V | 20 V | x 1.3 | x 1 | x 1 | x 1 | 3 µV |
| 3 µV | 8.48 µV | 7 V | 7 V | x 3.7 | x 3.33 | x 1 | x 3.33 | 10 µV |
| 3 µV | 8.48 µV | 2 V | 2 V | x 13 | x 10 | x 1 | x 10 | 30 µV |
| 3 µV | 8.48 µV | 700 mV | 700 mV | x 37.0 | x 33.3 | x 1 | x 33.3 | 100 µV |
| 3 µV | 8.48 µV | 200 mV | 200 mV | x 128 | x 100 | x 1 | x 100 | 300 µV |
| 3 µV | 8.48 µV | 70 mV | 70 mV | x 370 | x 333 | x 1 | x 333 | 1 mV |
| 3 µV | 8.48 µV | 200 mV | 200 mV | x 128 | x 100 | x 10 | x 1000 | 3 mV |
| 3 µV | 8.48 µV | 70 mV | 70 mV | x 370 | x 333 | x 10 | x 3330 | 10 mV |
| 3 µV | 8.48 µV | 200 mV | 200 mV | x 128 | x 100 | x 100 | x 10000 | 30 mV |
| 3 µV | 8.48 µV | 70 mV | 70 mV | x 370 | x 333 | x 100 | x 33300 | 100 mV |
| 3 µV | 8.48 µV | 200 mV | 200 mV | x 128 | x 100 | x 1000 | x 100000 | 300 mV |
| 3 µV | 8.48 µV | 70 mV | 70 mV | x 370 | x 333 | x 1000 | x 333000 | 1 V |



5 CONNECTIONS

The external connections to the 442 lock-in amplifier are shown in Figure 9.

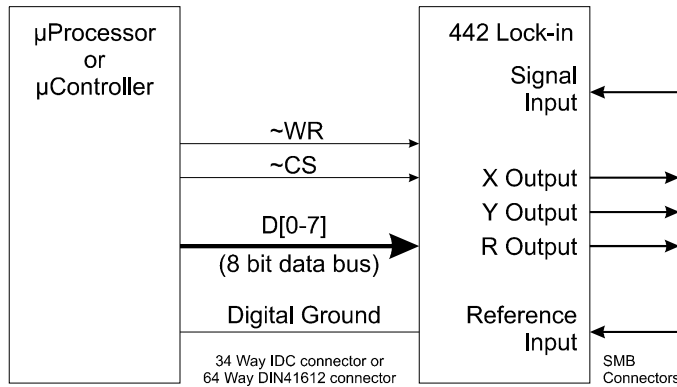

Figure 9 - External Connections

The digital connections to the μ Processor or μ Controller are made by one of two connectors, a 34 way IDC connector or a DIN41612 connector. One or other or both of these connectors may be fitted to the 442 board, though care must be made that signal conflicts do not occur if both connectors are used.

5.1 DIN41612 Connector

The DIN41612 connector uses the following pins:

| Name | Number | Description |
|--|--|---|
| ~CS | 19A | Active low Chip Select line. This pin must be held low when writing data to the board. |
| ~WR | 20C | Active low WRite lines. This pin must be taken low to write data to the board. The data is latched on the rising edge of ~WR and the data should be valid 20nS before and 10nS after this edge. |
| D0 D1 D2 D3 D4 D5 D6 D7 | 3A 3C 4A 4C 5A 5C 6A 6C | Data Bus |
| +15V | 30C | Power Connection - 55mA |
| 0V | 1A, 1C, 7C, 19C, 21C, 26A, 32A, 32C | Digital Ground Connection |
| -15V | 30A | Power Connection - 40mA |



Scitec Instruments Ltd

Bartles Industrial Estate Tel: +44 (0)1209 314 608 scitec@scitec.uk.com
 North Street, Redruth Fax: +44 (0)1209 314 609 www.scitec.uk.com
 Cornwall TR15 1HR Fax2: +44 (0)870 1600 860

Please note that the pin numbers are labelled on the back of the connector next to the solder pins and as per Figure 10. Please also note that some connectors have P1~A on the front face. Rather confusingly, this A is actually next to row C pins.

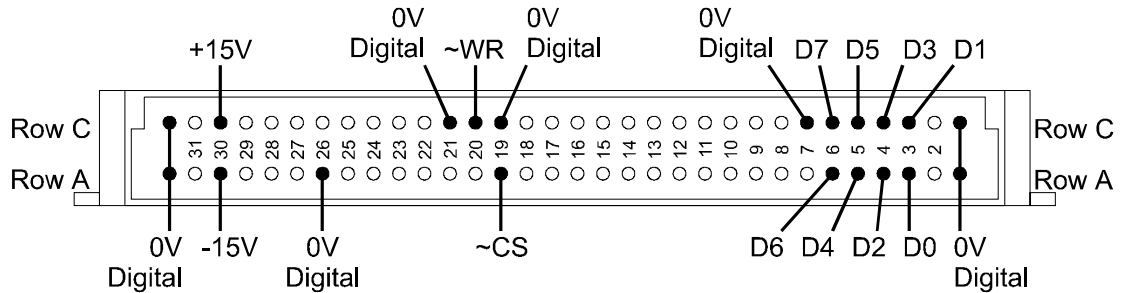

Figure 10 - 64 Pin DIN41612 Connector

5.2 34 Way IDC Connector

The 34 way IDC connector uses the following pins:

| Name | Number | Description |
|----------|--------|---|
| ~WR | 1 | Connected to Pin 23 |
| ~CS | 2 | Connected to Pin 25 |
| D0 | 3 | Data Line |
| DGND | 4 | Digital Ground |
| D1 | 5 | Data Bus |
| DGND | 6 | Digital Ground |
| D2 | 7 | Data Line |
| DGND | 8 | Digital Ground |
| D3 | 9 | Data Line |
| DGND | 10 | Digital Ground |
| D4 | 11 | Data Line |
| DGND | 12 | Digital Ground |
| D5 | 13 | Data Line |
| DGND | 14 | Digital Ground |
| D6 | 15 | Data Line |
| DGND | 16 | Digital Ground |
| D7 | 17 | Data Line |
| DGND | 18 | Digital Ground |
| Reserved | 19 | Do not connect |
| DGND | 20 | Digital Ground |
| Reserved | 21 | Do not connect |
| DGND | 22 | Digital Ground |
| ~WR | 23 | Active low WRite line. This pin must taken low to write data to the board. The data is latched on the rising edge of ~WR and the data should be valid 20nS before and 10nS after this edge. |
| DGND | 24 | Digital Ground |



Scitec Instruments Ltd

Bartles Industrial Estate Tel: +44 (0)1209 314 608 scitec@scitec.uk.com
 North Street, Redruth Fax: +44 (0)1209 314 609 www.scitec.uk.com
 Cornwall TR15 1HR Fax2: +44 (0)870 1600 860

| | | |
|----------|----|--|
| ~CS | 25 | Active low Chip Select line. This pin must be held low when writing data to the board. |
| DGND | 26 | Digital Ground |
| Reserved | 27 | Do not connect |
| Reserved | 28 | Do not connect |
| Output | 29 | Analogue Output from the board. |
| AGND | 30 | Ground Connection |
| +15V | 31 | Power Connection |
| -15V | 32 | Power Connection |
| +15V | 33 | Power Connection |
| -15V | 34 | Power Connection |

Pin 1 of the connector has a small triangle moulded into the plastic close to the pin. This is often difficult to find. See also Figure 11.

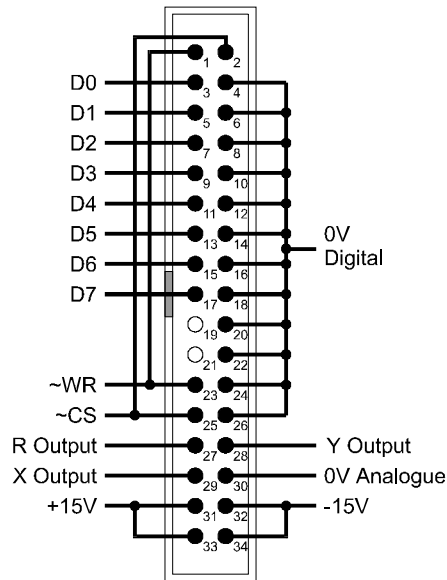

Figure 11 - 34 Way IDC Connector



6 POWER SUPPLY

6.1 Power Connections

A well regulated $\pm 15\text{V}$ DC supply is required to power the lock-in amplifier board. Power supply filters are used onboard to drive the analogue circuitry, however the better the power supply the better the performance of the board. A $\pm 12\text{V}$ DC supply can also be used to power the board but this will reduce the maximum signal size by a similar margin. E.g. A 10V rms AC input signal will be clipped as it has a peak amplitude of 14V .

6.2 Earth Connections for High Voltage / ESD Protection

As lock-in amplifiers are often used in optics applications with lasers driven by high voltage power supplies, it is sometimes important to protect equipment from high voltage discharges. Electro-Static Discharge (ESD) protection is also important and is a requirement for CE marking. All analogue inputs and outputs to the 442 are protected by transient suppression devices but for full protection a case earth connection is required directly to the PCB.

To give full protection to the board from high voltages, a thick earth wire should be bonded to the board at one or other or both of the solder pads shown in Figure 12 and connected to case or chassis ground by as short a lead as possible. If this is done then links 2 and 3 should be made and links 1 and 4 should be open circuit. If the board is mounted on conductive pillars using the holes in the solder pads then this will provide a suitable earthing solution.

If the solder pads are not connected to case ground via a thick earth wire then links 1, 3 & 4 should be made and link 2 should be open circuit. In this case electro-static discharges will be conducted to either analogue or digital ground. As these routes pass close to sensitive components this method should be avoided if possible.

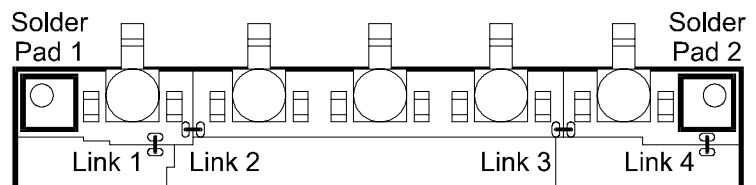

Figure 12 - Case Earth Connections

6.3 Analogue and Digital Ground

The 442 board has separate analogue and digital grounds. These grounds can be linked together on the board via a jumper (J1) or connected externally. There should not be more than 0.5V difference between the analogue and digital grounds.

Please see Figure 13 for more details.



Scitec Instruments Ltd

Bartles Industrial Estate Tel: +44 (0)1209 314 608 scitec@scitec.uk.com
North Street, Redruth Fax: +44 (0)1209 314 609 www.scitec.uk.com
Cornwall TR15 1HR Fax2: +44 (0)870 1600 860

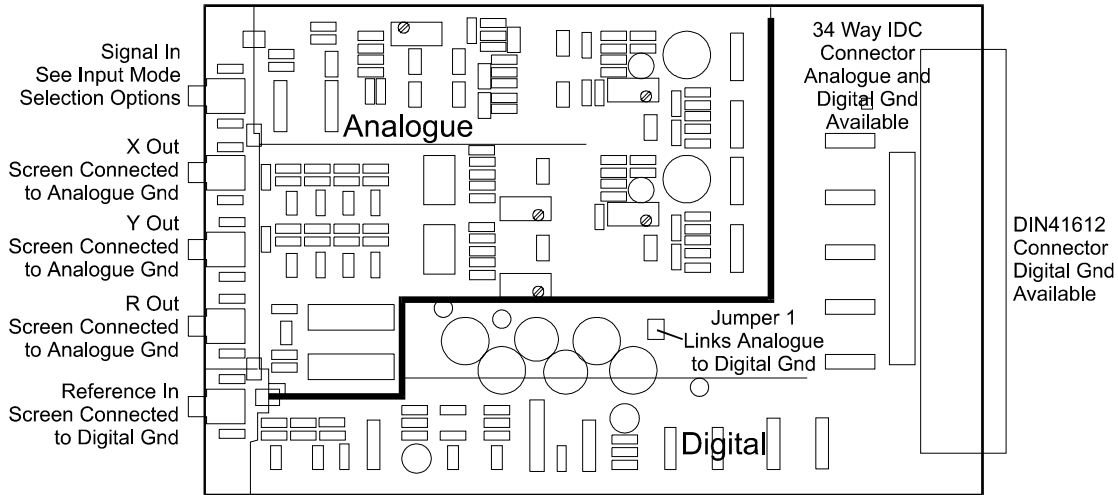

Figure 13 - Analogue and Digital Ground Connections



Bartles Industrial Estate Tel: +44 (0)1209 314 608 scitec@scitec.uk.com
 North Street, Redruth Fax: +44 (0)1209 314 609 www.scitec.uk.com
 Cornwall TR15 1HR Fax2: +44 (0)870 1600 860

7 WRITING CONTROL DATA TO THE BOARD

Data is written to the board using the \sim CS, \sim WR and Data lines as shown in Figure 14.

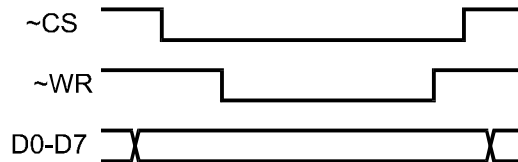

Figure 14 - A Sample Write Cycle

The \sim CS and \sim WR both need to be pulled low for data to be latched. If only one of \sim CS and \sim WR is to be used then the other line should be tied to ground.

| \sim CS | \sim WR | D0 to D7 | Result |
|-----------|-----------|------------|------------------------------|
| 0 | 0 | Data | Data transferred (See Notes) |
| 0 | 1 | Don't Care | - |
| 1 | 0 | Don't Care | - |
| 1 | 1 | Don't Care | - |

Notes:

The data will be latched into the 442 when either \sim CS or \sim WR go to a logic 1.

It is important that D0 to D7 are stable whilst \sim CS and \sim WR are at a logic 0.

The order in which \sim CS and \sim WR are activated is not important.

The data lines D5 to D7 operate effectively as address lines, selecting which signals are updated using pins D0 to D4 as shown in the following table.

| D7 | D6 | D5 | D4 | D3 | D2 | D1 | D0 |
|----|----|----|----------------|----------------|----------------|----------------|----------------|
| 0 | 0 | 0 | PotLoadY | PotDataY | PotLoadX | PotDataX | PotClk |
| 0 | 0 | 1 | TimeConstantY1 | TimeConstantY0 | - | InputMode1 | InputMode0 |
| 0 | 1 | 0 | TimeConstantY3 | TimeConstantY2 | InputGndPos | InputGainA1 | InputGainA0 |
| 0 | 1 | 1 | - | TimeConstantY4 | InputGndNeg | InputGainB1 | InputGainB0 |
| 1 | 0 | 0 | OutputGainY1 | OutputGainY0 | TimeConstantX2 | TimeConstantX1 | TimeConstantX0 |
| 1 | 0 | 1 | - | OutputGainY2 | - | TimeConstantX4 | TimeConstantX3 |
| 1 | 1 | 0 | ReferenceY1 | ReferenceY0 | OutputGainX2 | OutputGainX1 | OutputGainX0 |
| 1 | 1 | 1 | - | ReferenceY2 | ReferenceX2 | ReferenceX1 | ReferenceX0 |



Scitec Instruments Ltd

Bartles Industrial Estate Tel: +44 (0)1209 314 608 scitec@scitec.uk.com
North Street, Redruth Fax: +44 (0)1209 314 609 www.scitec.uk.com
Cornwall TR15 1HR Fax2: +44 (0)870 1600 860

As an example, to set the following:

TimeConstantY3 = 1

TimeConstantY2 = 1

InputGndPos = 1

InputGainA1 = 0

InputGainA0 = 1

then the number 01011101b, 5Dh or 93d^[1] should be written to the board.

At power up, all the above signals are in an unknown state. It therefore takes a total of eight writes to the board, one write for each of the above rows, to put the board into a known state. However, this is not enough to completely set up the board as the fine phase control and output offset circuitry requires multiple writes to PotLoadX&Y, PotDataX&Y and PotClk to program them.

7.1 Setting Fine Phase and Output Offset

The fine phase and output offsets are controlled with digital potentiometers. These pots are controlled by the signals PotLoadX&Y, PotDataX&Y and PotClk which operates as a serial interface.

| D7 | D6 | D5 | D4 | D3 | D2 | D1 | D0 |
|----|----|----|----------|----------|----------|----------|--------|
| 0 | 0 | 0 | PotLoadY | PotDataY | PotLoadX | PotDataX | PotClk |

At power up, PotLoadX&Y, PotDataX&Y and PotClk are in an unknown state. After power up these signals should all be set to 0. This is achieved by writing 0000000b, 00h or 0d to the board.

To set the values of the fine phase and output offset, a total of 35 writes need to be made to the board, with the data being output serially to PotDataX and PotDataY. The actual data is loaded on the 35th write cycle. This process is shown below.

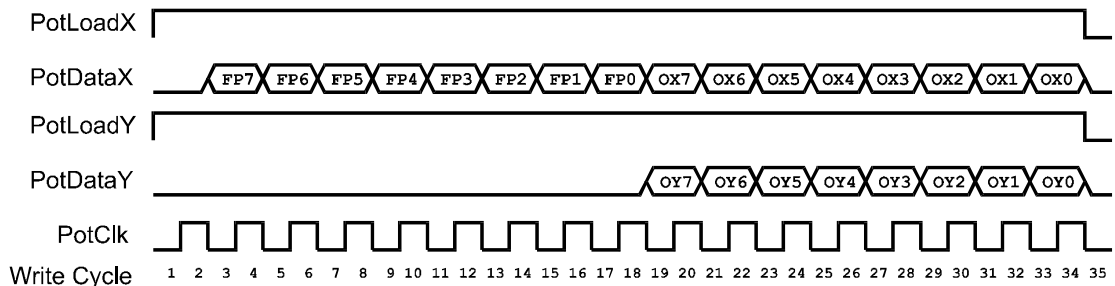

Writing Data to the Digital Potentiometers

^[1] 01011101b means the number 01011101 in binary, 5Dh means the number 5D in hex and 93d means the number 93 in decimal.



Scitec Instruments Ltd

Bartles Industrial Estate Tel: +44 (0)1209 314 608 scitec@scitec.uk.com
 North Street, Redruth Fax: +44 (0)1209 314 609 www.scitec.uk.com
 Cornwall TR15 1HR Fax2: +44 (0)870 1600 860

The values FP7 to FP0 combine to produce an 8 bit number which controls the Fine Phase setting. Example values are shown below.

| FP7 | FP6 | FP5 | FP4 | FP3 | FP2 | FP1 | FP0 | Binary | Hex | Decimal | Fine Phase Shift Setting |
|-----|-----|-----|-----|-----|-----|-----|-----|----------|-----|---------|--------------------------|
| 0 | 0 | 0 | 0 | 0 | 0 | 0 | 0 | 00000000 | 00 | 0 | 0° |
| 0 | 0 | 0 | 0 | 0 | 0 | 0 | 1 | 00000001 | 01 | 1 | 0.59° |
| 0 | 1 | 0 | 0 | 1 | 1 | 0 | 1 | 01001101 | 4D | 77 | 45.29° |
| 1 | 0 | 0 | 0 | 0 | 0 | 0 | 0 | 10000000 | 80 | 128 | 75.29° |
| 1 | 0 | 0 | 1 | 1 | 0 | 0 | 1 | 10011001 | 99 | 153 | 90° |
| 1 | 1 | 1 | 1 | 1 | 1 | 1 | 1 | 11111111 | FF | 255 | 150° |

The values of OX7 to OX0 combine to produce an 8 bit number which controls the X channel output offset. The values of OY7 to OY0 combine to produce an 8 bit number which controls the Y channel output offset. Example values are shown below. The Y channel is similar.

| OX7 | OX6 | OX5 | OX4 | OX3 | OX2 | OX1 | OX0 | Binary | Hex | Decimal | Output Offset Setting |
|-----|-----|-----|-----|-----|-----|-----|-----|----------|-----|---------|-----------------------|
| 0 | 0 | 0 | 0 | 0 | 0 | 0 | 0 | 00000000 | 00 | 0 | -1V |
| 0 | 0 | 0 | 0 | 0 | 0 | 0 | 1 | 00000001 | 01 | 1 | -0.992V |
| 0 | 1 | 0 | 0 | 0 | 0 | 0 | 0 | 01000000 | 40 | 64 | -0.5V |
| 1 | 0 | 0 | 0 | 0 | 0 | 0 | 0 | 10000000 | 80 | 128 | 0V |
| 1 | 1 | 0 | 0 | 0 | 0 | 0 | 0 | 11000000 | C0 | 192 | +0.5V |
| 1 | 1 | 1 | 1 | 1 | 1 | 1 | 1 | 11111111 | FF | 255 | 0.992V |

As a final example, to set the following:

fine phase = 45.3° (FP=01001101b)

X channel output offset = +0.5V (OX=11000000)

Y channel output offset = -0.992V (OY=00000001)

then it is necessary to send the following 35 values to the board:

(It is assumed that PotLoadX and PotLoadY were set to 0 before this data is sent)

| Write Cycle | Value in Binary | Value in Hex | Value in Decimal | Description |
|-------------|-----------------|--------------|------------------|-------------|
| 1 | 00010100 | 04 | 4 | - |
| 2 | 00010101 | 05 | 5 | - |
| 3 | 00010100 | 04 | 4 | FP7 |
| 4 | 00010101 | 05 | 5 | FP7 |
| 5 | 00010110 | 06 | 6 | FP6 |
| 6 | 00010111 | 07 | 7 | FP6 |
| 7 | 00010100 | 04 | 4 | FP5 |
| 8 | 00010101 | 05 | 5 | FP5 |



Scitec Instruments Ltd

Bartles Industrial Estate Tel: +44 (0)1209 314 608 scitec@scitec.uk.com
 North Street, Redruth Fax: +44 (0)1209 314 609 www.scitec.uk.com
 Cornwall TR15 1HR Fax2: +44 (0)870 1600 860

| Write Cycle | Value in Binary | Value in Hex | Value in Decimal | Description |
|-------------|-----------------|--------------|------------------|-------------|
| 9 | 00010100 | 04 | 4 | FP4 |
| 10 | 00010101 | 05 | 5 | FP4 |
| 11 | 00010110 | 06 | 6 | FP3 |
| 12 | 00010111 | 07 | 7 | FP3 |
| 13 | 00010110 | 06 | 6 | FP2 |
| 14 | 00010111 | 07 | 7 | FP2 |
| 15 | 00010100 | 04 | 4 | FP1 |
| 16 | 00010101 | 05 | 5 | FP1 |
| 17 | 00010110 | 06 | 6 | FP0 |
| 18 | 00010111 | 07 | 7 | FP0 |
| 19 | 00010110 | 06 | 6 | OY7 / OX7 |
| 20 | 00010111 | 07 | 7 | OY7 / OX7 |
| 21 | 00010110 | 06 | 6 | OY6 / OX6 |
| 22 | 00010111 | 07 | 7 | OY6 / OX6 |
| 23 | 00010100 | 04 | 4 | OY5 / OX5 |
| 24 | 00010101 | 05 | 5 | OY5 / OX5 |
| 25 | 00010100 | 04 | 4 | OY4 / OX4 |
| 26 | 00010101 | 05 | 5 | OY4 / OX4 |
| 27 | 00010100 | 04 | 4 | OY3 / OX3 |
| 28 | 00010101 | 05 | 5 | OY3 / OX3 |
| 29 | 00010100 | 04 | 4 | OY2 / OX2 |
| 30 | 00010101 | 05 | 5 | OY2 / OX2 |
| 31 | 00010100 | 04 | 4 | OY1 / OX1 |
| 32 | 00010101 | 05 | 5 | OY1 / OX1 |
| 33 | 00011100 | 04 | 4 | OY0 / OX0 |
| 34 | 00011101 | 05 | 5 | OY0 / OX0 |
| 35 | 00000000 | 00 | 0 | load |

7.2 Input Stage Settings

The input stage settings allow a number of different options to be used as the input to the lock-in amplifier board. The signals used to control the input stage are as follows.

| D7 | D6 | D5 | D4 | D3 | D2 | D1 | D0 |
|----|----|----|----------------|----------------|-------------|-------------|-------------|
| 0 | 0 | 1 | TimeConstantY1 | TimeConstantY0 | - | InputMode1 | InputMode0 |
| 0 | 1 | 0 | TimeConstantY3 | TimeConstantY2 | InputGndPos | InputGainA1 | InputGainA0 |
| 0 | 1 | 1 | - | TimeConstantY4 | InputGndNeg | InputGainB1 | InputGainB0 |

InputGndPos, InputGndNeg, InputMode0 & InputMode1 set the mode of operation of the input stage. InputGainA0, A1, B0 & B1 set the gain for the input stage.

There are 6 different modes of the input stage and these are set as follows:



Scitec Instruments Ltd

Bartles Industrial Estate Tel: +44 (0)1209 314 608 scitec@scitec.uk.com
 North Street, Redruth Fax: +44 (0)1209 314 609 www.scitec.uk.com
 Cornwall TR15 1HR Fax2: +44 (0)870 1600 860

Single Ended DC Coupled

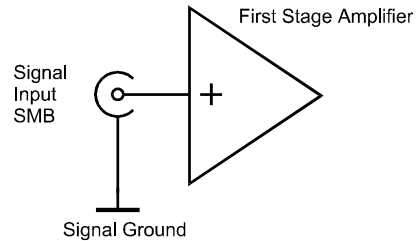

| | |
|-------------|---|
| InputMode0 | 0 |
| InputMode1 | 1 |
| InputGndPos | 1 |
| InputGndNeg | 0 |

Single Ended DC Coupled Centre Ground

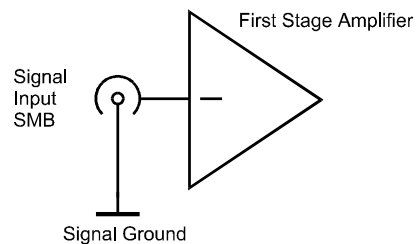

| | |
|-------------|---|
| InputMode0 | 0 |
| InputMode1 | 1 |
| InputGndPos | 0 |
| InputGndNeg | 1 |

Differential DC Coupled

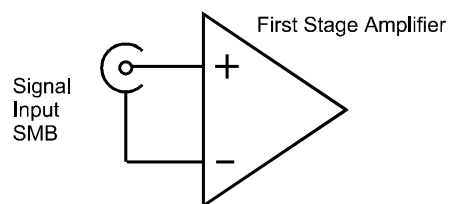

| | |
|-------------|---|
| InputMode0 | 0 |
| InputMode1 | 1 |
| InputGndPos | 1 |
| InputGndNeg | 1 |

Single Ended AC Coupled



Scitec Instruments Ltd

Bartles Industrial Estate Tel: +44 (0)1209 314 608 scitec@scitec.uk.com
 North Street, Redruth Fax: +44 (0)1209 314 609 www.scitec.uk.com
 Cornwall TR15 1HR Fax2: +44 (0)870 1600 860

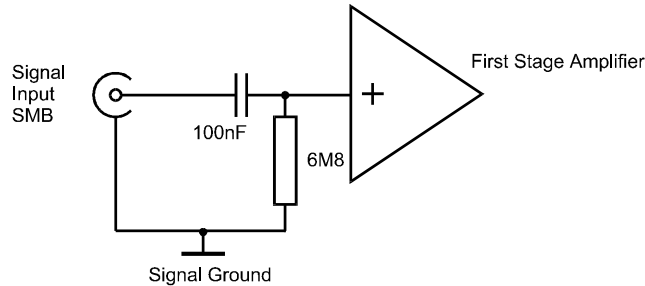

| | |
|-------------|---|
| InputMode0 | 1 |
| InputMode1 | 0 |
| InputGndPos | 1 |
| InputGndNeg | 0 |

Differential AC Coupled

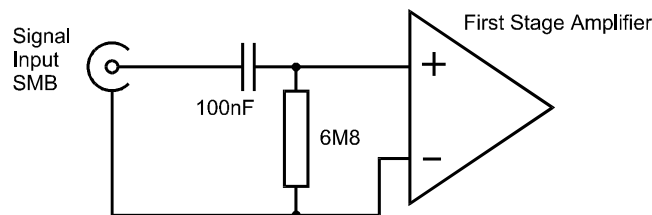

| | |
|-------------|---|
| InputMode0 | 1 |
| InputMode1 | 0 |
| InputGndPos | 1 |
| InputGndNeg | 1 |

Inputs Shorted

This mode can be useful as a test mode. Please note that the input SMB connector is shorted by a 100nF capacitor.

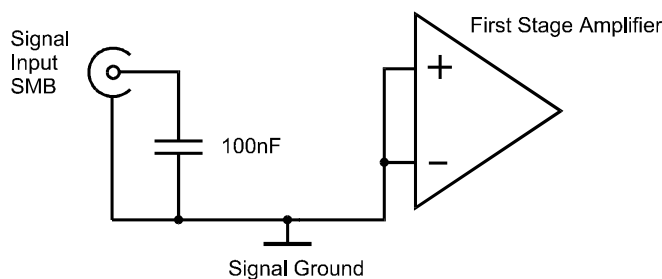

| | |
|-------------|---|
| InputMode0 | 1 |
| InputMode1 | 0 |
| InputGndPos | 0 |
| InputGndNeg | 0 |



Scitec Instruments Ltd

Bartles Industrial Estate Tel: +44 (0)1209 314 608 scitec@scitec.uk.com
 North Street, Redruth Fax: +44 (0)1209 314 609 www.scitec.uk.com
 Cornwall TR15 1HR Fax2: +44 (0)870 1600 860

The input gain stages are set as follows:

Input Gain Stage A

| InputGainA1 | InputGainA0 | Nominal | Actual |
|-------------|-------------|---------|--------|
| 1 | 1 | x1 | x1.00 |
| 1 | 0 | x10 | x9.90 |
| 0 | 1 | x100 | x100.2 |
| 0 | 0 | x110 | x110.1 |

Input Gain Stage B

| InputGainB1 | InputGainB0 | Nominal | Actual |
|-------------|-------------|---------|--------|
| 1 | 1 | x1 | x1.00 |
| 1 | 0 | x3.33 | x3.32 |
| 0 | 1 | x10 | x9.90 |
| 0 | 0 | x12 | x12.22 |

7.3 Output Stage Settings

The low pass filter between the demodulator and the output gain stage has its time constant set by the signals TimeConstantX0 to X4 for the X channel and TimeConstantY0 to Y4 for the Y channel.

| D7 | D6 | D5 | D4 | D3 | D2 | D1 | D0 |
|----|----|----|----------------|----------------|----------------|----------------|----------------|
| 0 | 0 | 1 | TimeConstantY1 | TimeConstantY0 | - | InputMode1 | InputMode0 |
| 0 | 1 | 0 | TimeConstantY3 | TimeConstantY2 | InputGndPos | InputGainA1 | InputGainA0 |
| 0 | 1 | 1 | - | TimeConstantY4 | InputGndNeg | InputGainB1 | InputGainB0 |
| 1 | 0 | 0 | OutputGainY1 | OutputGainY0 | TimeConstantX2 | TimeConstantX1 | TimeConstantX0 |
| 1 | 0 | 1 | - | OutputGainY2 | - | TimeConstantX4 | TimeConstantX3 |

The time constant settings possible are as follows:

| TimeConstantX TimeConstantY | | | | | Nominal | Actual |
|--------------------------------|----------|----------|----------|----------|---------|--------|
| X4 Y4 | X3 Y3 | X2 Y2 | X1 Y1 | X0 Y0 | | |
| 1 | 1 | 0 | 0 | 0 | - | 82µS |
| 1 | 1 | 1 | 0 | 0 | - | 87µS |
| 1 | 1 | 0 | 1 | 0 | 100µS | 98µS |
| 1 | 1 | 1 | 1 | 0 | - | 105µS |
| 1 | 1 | 0 | 0 | 1 | 330µS | 330µS |
| 1 | 1 | 1 | 0 | 1 | - | 430µS |
| 1 | 1 | 0 | 1 | 1 | 1mS | 990µS |
| 1 | 1 | 1 | 1 | 1 | 3.3mS | 3.3mS |



Scitec Instruments Ltd

Bartles Industrial Estate Tel: +44 (0)1209 314 608 scitec@scitec.uk.com
 North Street, Redruth Fax: +44 (0)1209 314 609 www.scitec.uk.com
 Cornwall TR15 1HR Fax2: +44 (0)870 1600 860

| TimeConstantX TimeConstantY | | | | | Nominal | Actual |
|--------------------------------|----------|----------|----------|----------|---------|--------|
| X4 Y4 | X3 Y3 | X2 Y2 | X1 Y1 | X0 Y0 | | |
| 1 | 0 | 0 | 0 | 0 | - | 8.2mS |
| 1 | 0 | 1 | 0 | 0 | - | 8.7mS |
| 1 | 0 | 0 | 1 | 0 | 10mS | 9.8mS |
| 1 | 0 | 1 | 1 | 0 | - | 10.5mS |
| 1 | 0 | 0 | 0 | 1 | 33mS | 33.0mS |
| 1 | 0 | 1 | 0 | 1 | - | 43.0mS |
| 1 | 0 | 0 | 1 | 1 | 100mS | 99mS |
| 1 | 0 | 1 | 1 | 1 | 330mS | 330mS |
| 0 | 1 | 0 | 0 | 0 | - | 820mS |
| 0 | 1 | 1 | 0 | 0 | - | 870mS |
| 0 | 1 | 0 | 1 | 0 | 1S | 980mS |
| 0 | 1 | 1 | 1 | 0 | - | 1.05S |
| 0 | 1 | 0 | 0 | 1 | 3.3S | 3.30S |
| 0 | 1 | 1 | 0 | 1 | - | 4.30S |
| 0 | 1 | 0 | 1 | 1 | 10S | 9.9S |
| 0 | 1 | 1 | 1 | 1 | 33S | 33S |

The output gain stage settings for the X and the Y channels are controlled by signals OutputGainX0 to OutputGainX2 and OutputGainY0 to OutputGainY2 respectively.

| D7 | D6 | D5 | D4 | D3 | D2 | D1 | D0 |
|----|----|----|--------------|--------------|----------------|----------------|----------------|
| 1 | 0 | 0 | OutputGainY1 | OutputGainY0 | TimeConstantX2 | TimeConstantX1 | TimeConstantX0 |
| 1 | 0 | 1 | - | OutputGainY2 | - | TimeConstantX4 | TimeConstantX3 |
| 1 | 1 | 0 | ReferenceY1 | ReferenceY0 | OutputGainX2 | OutputGainX1 | OutputGainX0 |



Scitec Instruments Ltd

Bartles Industrial Estate Tel: +44 (0)1209 314 608 scitec@scitec.uk.com
 North Street, Redruth Fax: +44 (0)1209 314 609 www.scitec.uk.com
 Cornwall TR15 1HR Fax2: +44 (0)870 1600 860

Output Gain Settings are as follows:

| | | | Output Gain Stage | |
|------------------------------|------------------------------|------------------------------|-------------------|--------|
| OutputGainX2 OutputGainY2 | OutputGainX1 OutputGainY2 | OutputGainX0 OutputGainY0 | Nominal | Actual |
| 1 | 1 | 1 | x1 | x1.00 |
| 1 | 1 | 0 | x10 | x11 |
| 1 | 0 | 1 | x100 | x101 |
| 1 | 0 | 0 | - | x110 |
| 0 | 1 | 1 | x1000 | x1001 |
| 0 | 1 | 0 | - | x1010 |
| 0 | 0 | 1 | - | x1100 |
| 0 | 0 | 0 | - | x1110 |

7.4

Reference Settings

By changing the control signals ReferenceX0 to X2 and ReferenceY0 to Y2, it is possible to phase shift the reference signal in 90° increments and to double the demodulation frequency for each channel separately.

| D7 | D6 | D5 | D4 | D3 | D2 | D1 | D0 |
|----|----|----|-------------|-------------|--------------|--------------|--------------|
| 1 | 1 | 0 | ReferenceY1 | ReferenceY0 | OutputGainX2 | OutputGainX1 | OutputGainX0 |
| 1 | 1 | 1 | - | ReferenceY2 | ReferenceX2 | ReferenceX1 | ReferenceX0 |

| ReferenceX2 ReferenceY2 | ReferenceX1 ReferenceY1 | ReferenceX0 ReferenceY0 | Coarse Phase |
|----------------------------|----------------------------|----------------------------|----------------|
| 0 | 1 | 0 | 0° @ 2 x Ref |
| 0 | 1 | 1 | 90° @ 2 x Ref |
| 0 | 0 | 0 | 180° @ 2 x Ref |
| 0 | 0 | 1 | 270° @ 2 x Ref |
| 1 | 1 | 0 | 0° @ Ref |
| 1 | 1 | 1 | 90° @ Ref |
| 1 | 0 | 0 | 180° @ Ref |
| 1 | 0 | 1 | 270° @ Ref |



Scitec Instruments Ltd

Bartles Industrial Estate Tel: +44 (0)1209 314 608 scitec@scitec.uk.com
North Street, Redruth Fax: +44 (0)1209 314 609 www.scitec.uk.com
Cornwall TR15 1HR Fax2: +44 (0)870 1600 860