



HTPA

Thermopile Array with Ge-Lense f = 4mm

Heimann offers a world new fully monolithic thermopile sensor array. This allows the measurement of temperature distribution of the environment, where very high resolutions are not necessary, such as person detection, surveillance of temperature critical surfaces, hotspot or fire detection, energy management and security applications. Other applications can be found in industrial process control and air condition control.

The benefits of this technology are low costs, the very small power consumption, small size, as well as the high sensitivity of the system. They fit in a TO8 housing, which provides small dimensions and a reliable mechanical assembly.

Principal Schematic:

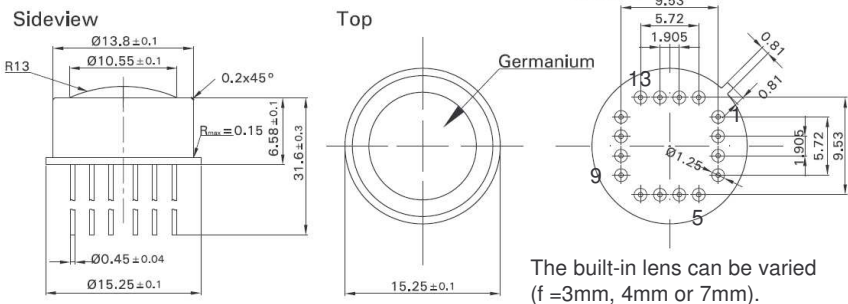
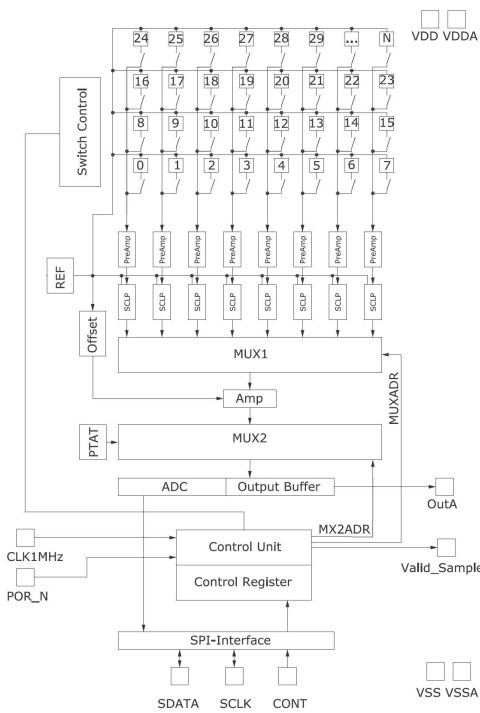

Pin	Name	Description	Type
1	VSS	Negative power supply voltage	Power
2	CONT	Control Pin for SPI	Digital Input
3	OUT_A	Analog Output	Analog Output
4	VCM_C	Common mode voltage	Reference Voltage
5	VCM_OUT	Common mode voltage	Reference Voltage
6	VREF_N	Negative reference voltage for ADC	Reference Voltage
7	VREF_P	Positive reference voltage for ADC	Reference Voltage
8	VREF_1225V	1.225V reference voltage	Reference Voltage
9	AGND	Analog ground for ADC	Reference Voltage
10	VDDA	Positive power supply voltage	Power
11	VDD	Positive power supply voltage	Power
12	POR_N	Power on reset, negated	Digital Input
13	CLK_1MHZ	Master clock	Digital Input
14	VSAM	Valid sample	Digital Output
15	SCLK_IO	Clock input/output for SPI	Digital Input/Output
16	DATA_IO	Data input/output for SPI	Digital Input/Output

Parameter	Comment	HTPA 8x8	HTPA 16x16	Unit
Technology		n-poly/p-poly Si		
Element resistance		approx. 80		kOhm
Sensitivity	without optics and filter	n/a	approx. 45	V/W
NETD	@ 1Hz	n/a	0.3	K
Total noise		n/a	50	nV/Hz ^{1/2}
Thermal pixel time constant		<4		ms
Internal ADC		12		bit
Digital interface		SPI		
Analog output		Yes		
2 point selectable gains		2640x / 7920 x		
Pitch		300	220	µm
Absorber size		210x210	160x160	µm ²
Max. framerate	without averaging	66.8	18.6	Hz
Supply voltage		5		V
		4 internal amps + MUX	8 internal amps + MUX	
		64 sensitive elements	256 sensitive elements	

Modifications reserved Rev.01 / 25.04.2008



Application Set

For demonstration and easy application of our arrays we designed an evaluating processor unit in a modular metal case for better handling. The module's field of view depends on housing, the built-in lens and can be varied on demand.

The object temperature range can be easily changed by software.

The digital data stream is transferred from the module to the PCB via SPI and contains the signal voltages of the elements, the offset of the amplifiers and the ambient temperature information of the module. The analogous data stream contains the same information and can be sampled by an external ADC. The microcontroller processes the data and sends it via RS232 or TCP/IP to a PC. On PC side the data stream is logged and visualized with a Graphical User Interface.

The given software allows you to start your measurements and testing almost immediately.

Applications

- Person detection
- Fire detection
- Hotspot detection
- Energy management
- Security cameras
- Industrial process control
- Air condition control

Benefit

- Low cost
- Low power consumption
- Short time constant
- High sensitivity of the system
- TO8/TO39 housing

Options:

- Communication via RS 232 or TCP/IP
- Several Lenses for different field of view

Software features:

- False color images with auto scaling
- Selectable frame rate
- Data log mode
- Contrast adjustment
- Interpolation
- Temperature display

Included in delivery:

- Array module
- Cable interface
- AC adapter
- Tripod
- Software

Module dimension:

- Diameter 28 mm; length approx. 95 mm

