



PDI Series Photovoltaic IR Photodetectors

2-12 μ m IR PHOTODETECTORS Fast PHOTOVOLTAIC

FEATURES

- Ambient temperature operation
- No bias required
- *Fast* response time
- No $1/f$ (flicker) noise
- Operation from DC to VHF
- Perfect match to fast electronics
- Wide dynamic range

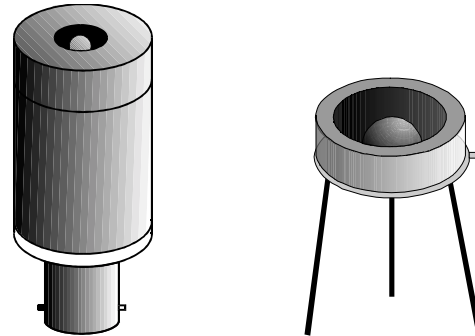

SPECTRAL RESPONSE

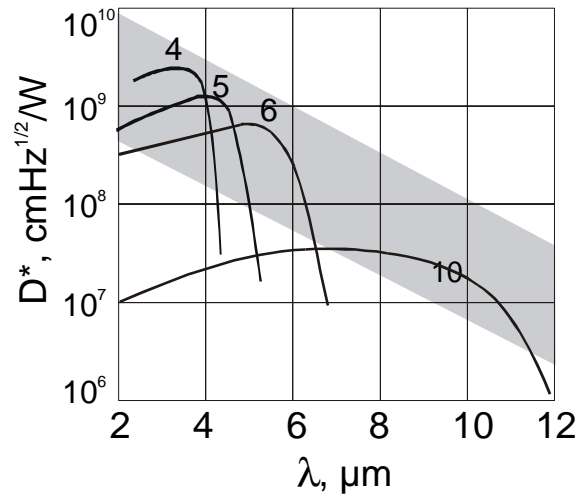

Spectral detectivities of PDI detectors.

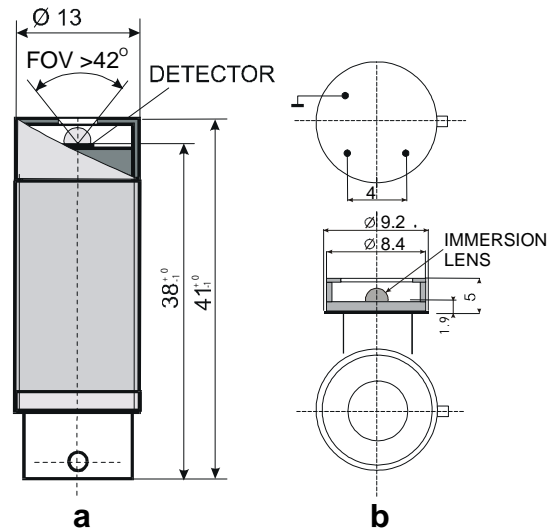

Devices are typically mounted in specialized packages with BNC connectors: **(a)** for broadband applications and **(b)** in modified TO-5-style packages for low frequency operation (DC to 20 MHz). The devices are usually delivered without windows.



DESCRIPTION

The PDI-*n* series photodetectors (where *n* is wavelength λ_{op} , in micrometers, for which the detector is optimized) are photovoltaic IR detectors which have been optically immersed to high refractive index CdZnTe hemispherical or hyperhemispherical lenses. These devices can be optimized for the maximum performance anywhere from 2 to 12 μm . High performance and stability are achieved by using a newly developed variable gap semiconductors (Hg-Cd-Zn-Te) as well as graded composition and doping level profiles and optimization of surface processing. Custom devices are available on request.

SPECIFICATIONS

Specifications are subject to change without notice. Specifications measured @20°C, 1x1 active area.

Characteristics	Units	PDI-4	PDI-5	PDI-6	PDI-8	PDI-10.6
Optimization λ	μm	4	5	6	8	10.6
Detectivity at λ_p at λ_{op}	$\text{cmHz}^{1/2}/\text{W}$	$\geq 3 \cdot 10^9$	$\geq 1.5 \cdot 10^9$	$\geq 8 \cdot 10^8$	$\geq 3 \cdot 10^8$	$\geq 5 \cdot 10^7$
		$\geq 1.5 \cdot 10^9$	$\geq 5 \cdot 10^8$	$\geq 3 \cdot 10^8$	$\geq 1 \cdot 10^8$	$\geq 1.5 \cdot 10^7$
Responsivity	V/W	≥ 30	≥ 6	≥ 2	≥ 1.5	≥ 0.15
Response Time	Nsec	≤ 15	≤ 15	≤ 12	≤ 7	≤ 1
Resistance	Ω	200 – 1500	60 – 250	10 – 150	30 – 300	10 – 150
Field of View*	Degrees	42				
Area	mm^2	0.2x0.2; 0.5x0.5; 1x1; 2x2 (Customer choice)				

* $\geq 42^\circ$ FOV devices are available only for hemispherically immersed devices with D^* reduced by a factor of ≈ 3

TYPICAL OPERATING CIRCUIT

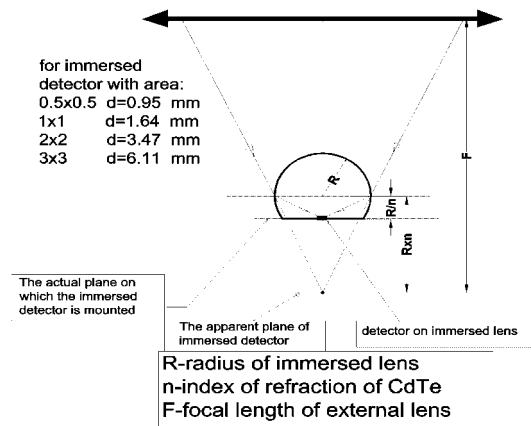
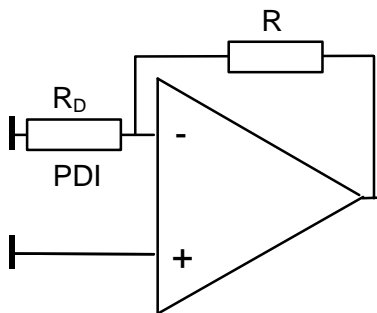

CAUTION

- CW optical power must not exceed $20\text{W}/\text{cm}^2$!
- Pulses shorter than $1\mu\text{s}$ must not exceed $10\text{kW}/\text{cm}^2$!
- Do not bias these detectors!

More Information: see J. Piotrowski et al., "New generation of near-room temperature photodetectors", Optical Engineering, May 1994, Vol. 33 No. 5, pages 1413-1421

We supply compatible low-noise preamplifiers with bandwidths from DC to 200 MHz or, AC-coupled, to 500+ MHz. These detectors require no bias voltage, exhibit no 1/f (flicker) noise, and thus have optimum performance from DC to very high frequencies.



Boston Electronics Corporation, 91 Boylston Street, Brookline MA 02445
(800)347-5445 or (617)566-3821 * fax (617)731-0935 * bouselec@boselec.com * www.boselec.com

04/06/2001