

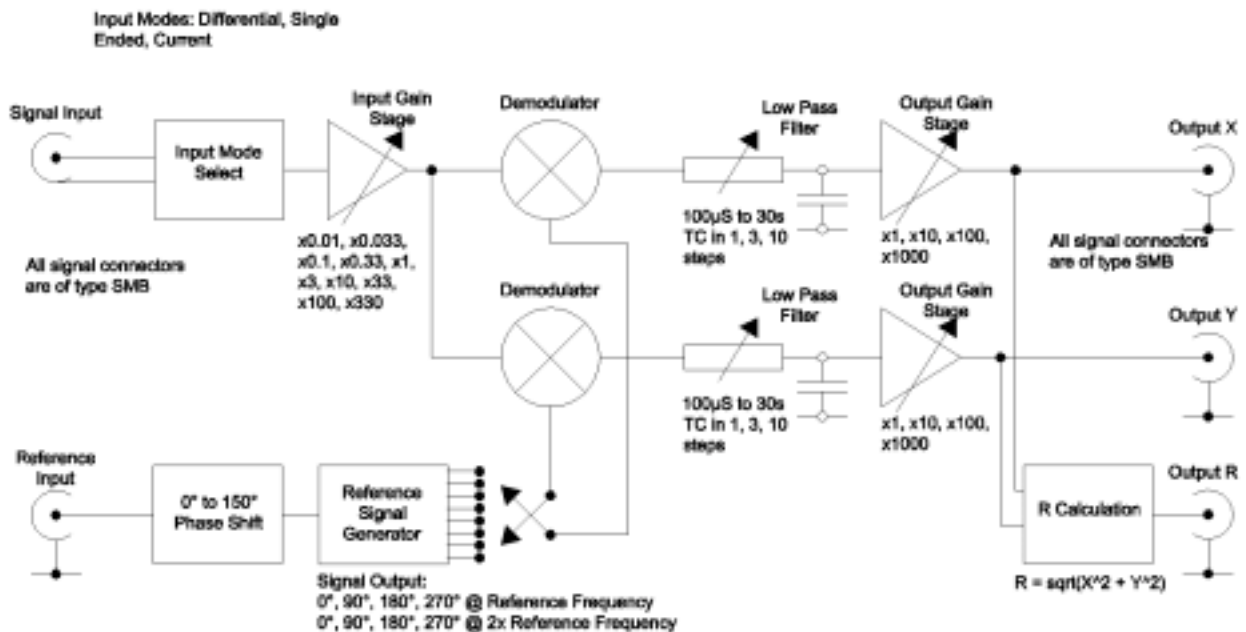

Model 441 OEM Dual Phase Lock-In Amplifier

Scitec Instruments' Model 441 OEM analogue lock-in amplifier uses advanced technology to provide a versatile high performance instrument.

- Dual phase operation
- Differential, single-ended or current input
- Gain settings from 3 μ V to 10V
- High performance wide bandwidth input gain stage
- Low pass filter output time constants from 100 μ s to 30s
- X, Y and R Outputs
- 1F and 2F reference signal operation
- 90° step and fine phase control

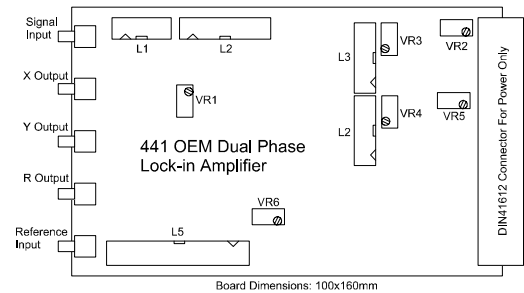

OPERATIONAL MODES

The 441 OEM analogue lock-in amplifier can operate in 2 main modes:

- Dual phase operation - 1 input signal with 2 demodulators operating at 90° apart providing the X and Y or real and imaginary parts of the input signal.
- Single channel 1F and 2F operation - 1 input signal and 2 demodulators operating at 1x and 2x the reference frequency to measure the first and second harmonic of the input signal.

INPUT SIGNAL CHANNELS

The input signal channel amplifies the input signals to a level suitable for the demodulator. High performance, low-noise, broad-band amplifiers are used throughout.

The input circuit can accept differential or single-ended inputs via the input SMB connectors. Jumper options within the unit allow the outer SMB contact or screen to act as a high impedance differential input or allow it to be connected to ground for single-ended operation. The 441 lock-in will also accept current inputs through the development of a voltage across a precision resistor. This mode is not guaranteed by Scitec.



The input channels are DC coupled rather than the more normal AC coupling seen on other lock-in amplifiers as the noise performance is improved.

Input Sensitivity	Differential or single ended voltage or current input via SMB socket 3 μ V to 10V in 1, 3, 10 steps. The input gain is set using jumpers enabling simple gain changes. One set of gain resistors are mounted on solder pillars so that they can be easily changed by the user with the aid of a soldering iron.
Input Impedance	10 ¹² Ω 1nF, dc coupled
Frequency	10Hz to 100kHz
Maximum Inputs	\pm 10V before saturation occurs.
Noise	Scitec Instruments no longer specify input noise values as this leads to comparison with other manufacturers data sheets which are clearly grossly in error. If you wish for details of these values then please contact us and we will explain the situation.
Gain Accuracy	1%
Gain Stability	200ppm/ $^{\circ}$ C
Dynamic Reserve	0dB to 80dB adjustable via jumpers.

DEMODULATOR

The input stage drives two high bandwidth demodulators to recover the input signal.

OUTPUT

The demodulator outputs are passed through low pass filters before being amplified for output.

Low Pass Filter Time Constant	100 μ S to 30s in 1, 3, 10 steps. The time constant is set using jumpers enabling simple time constant changes. One set of resistor capacitor values are mounted on solder pillars so that they can be easily modified with the aid of a soldering iron.
Outputs - SMB connectors	\pm 100mV to \pm 10V full scale output. Can be modified through jumper settings.
R Calculation	The modulus of the two output signals is produced, where $R = \sqrt{(X^2 + Y^2)}$.

REFERENCE CHANNEL

A single reference signal is used to generate the signals that drive both demodulators. A fine phase shifting circuit allows the reference signal to be phase shifted from 0 $^{\circ}$ to 150 $^{\circ}$ with relation to the signal input. A second circuit then produces signals that are phase shifted by 0 $^{\circ}$, 90 $^{\circ}$, 180 $^{\circ}$ and 270 $^{\circ}$ at both the reference frequency and twice the reference frequency. Any of these 8 signals can be used to drive either demodulator through the positioning of a set of jumpers.

Frequency	10Hz to 100kHz
Trigger	Standard TTL, 95% mark/space ratio min. Rising edge triggered.
Acquisition time	10s max.
Phase control	90 $^{\circ}$ steps + fine shift in range 0 $^{\circ}$ - 150 $^{\circ}$
Phase Drift	0.1 $^{\circ}$ / $^{\circ}$ C
1F and 2F operation	

GENERAL

Power	-15V, 0V, +5V, +15V DC @ 50mA per supply. Power connections are made via 64 pin type C DIN41612 connector. Signal connections are not possible via this connector.
Mechanical	100 x 160mm
Temperature range	0-50 $^{\circ}$ C (operational)
Warranty	2 years from date of shipment

