

OPTICAL CHOPPERS & LOCK INS

**VARIABLE SPEED
ROTATING DISK CHOPPERS**

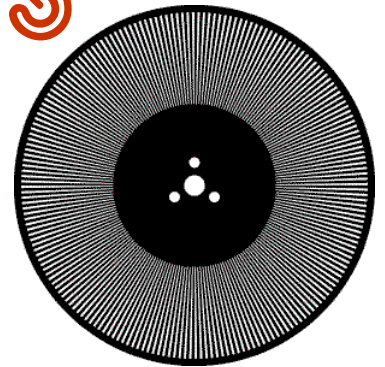

**DIGITAL AND ANALOG
LOCK-IN AMPLIFIERS**

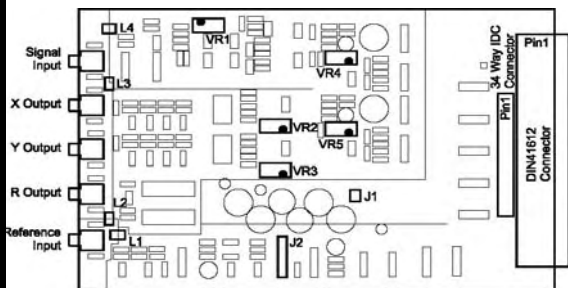

For laboratory use and
for dedicated incorporation into instrumentation

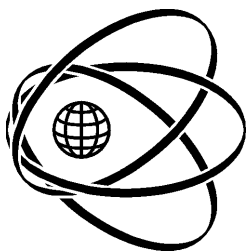

Boston Electronics Corporation

91 Boylston Street, Brookline MA 02445 USA
(800)347-5445 or (617)566-3821 fax (617)731-0935

www.boselec.com

boselec@boselec.com

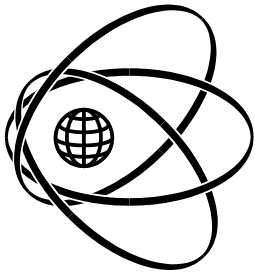

Boston Electronics Corporation

91 Boylston Street, Brookline, Massachusetts 02445 USA
(800)347-5445 or (617)566-3821 fax (617)731-0935
www.boselec.com boselec@boselec.com

450S Digital Lock-in Amplifier

Features

Scitec Instruments Model 450S is a dual phase DSP lock-in amplifier. It has been designed for computer control and features both Ethernet and RS232 interfaces. All settings can be managed under browser control. State of the art electronics have been used to produce an instrument that is exceptionally versatile and easy to use. The instrument performs all the usual measurements of a dual phase lock-in amplifier, measuring the in-phase and quadrature components, vector magnitude and phase angle.



- **Dual phase instrument**
- **Voltage or current input**
- **Gain settings from 1 μ V to 1 V**
- **Frequency range from 1 mHz to 200 kHz**
- **High performance wide bandwidth input gain stage**
- **Digital demodulation**
- **First and second order digital filters with time constants from 1 μ s to 500 ks**
- **Operation at 1/8, 1/4, 1/2, 1, 2, 4, 8th harmonics of the reference signal.**
- **Ethernet and RS232 interfaces**
- **Control selection and adjustment by onscreen menus and sub-menus via web browser**
- **All outputs are general purpose and fully programmable**

Lock-in amplifiers are used to measure the amplitude and phase of small AC signals in the presence of much larger noise levels. They are widely used to recover small optical signals such as those encountered in spectroscopy and studies of fluorescence and luminescence. However, they also have applications in many other fields including electronics and cryogenics where they can be used in component characterisation, bridge networks and to measure the resistance of superconductors. The output from a lock-in amplifier is a DC voltage proportional to the amplitude of the input signal but with the noise removed. It is also a function of the relative phase difference between the input signal and the associated reference signal. This property allows lock-in amplifiers to be used for measuring the phase properties of the input signal as well. Scitec Instruments DSP lock-in amplifiers are dual phase instruments. Dual phase lock-in amplifiers have two demodulators which make measurements with a 90° phase separation.

A key figure of merit used for lock-in amplifiers is dynamic reserve. The dynamic reserve of a lock-in amplifier is defined as the ratio of the noise to signal that is allowed before saturation occurs. The maximum dynamic reserve for the Model 450S is 100dB (*), allowing an input signal buried in noise of up to 100,000 times larger to be recovered.

(*) This figure is subject to change

Specifications

Input Signal Channel

The input signal channel amplifies the input signal to a level suitable for digitisation. High performance, low-noise, broad-band amplifiers are used throughout. The input circuitry can accept voltage or current inputs via the front panel signal input BNC.

- **Input: voltage or current inputs, via front panel BNC**
- **Sensitivity: 1 μ V to 1 V (for 1 V output) switched in 1, 2, 5, 10 steps**
- **Input Impedance: 108 ohm//50 pF, dc coupled**
- **Frequency: 1 mHz to 200 kHz**
- **Maximum Inputs: \pm 3 V before input protection circuitry comes into operation.**
- **Dynamic Reserve: 100 dB max(*), limited by a maximum signal input noise voltage of 1 V**

(*) This figure is subject to change

Demodulator

The output of the signal input stage is processed using a very high bandwidth digital demodulator to recover the input signal.

Low Pass Filters

Following demodulation, first or second order low pass filters may be selected.

- **Time Constant: 1 μ s to 500 ks in 1, 2, 5, 10 steps**
- **Output: \pm 1 V output corresponds to full scale input, with headroom to 4.5 V. Short circuit protection included**
- **Offset: Up to 1x full scale, switchable on or off**
- **780 kHz output update rate**

Reference Channel

- **Frequency: 1 mHz to 200 kHz**
- **Input Impedance: 100K**
- **Trigger: Zero crossing at 0 V and -0.1 V. TTL/CMOS trigger points at 2 V and 1 V**
- **Acquisition Time: 1.5 cycles + 2 μ s**

General

- **Power: 9 V, 1.8 A**
- **Mechanical: 435(W) x 44(H) x 300(D) mm**
- **Temperature range: 0-50°C**

Warranty: 2 years from date of shipment

For more information contact **Boston Electronics** or -

Scitec Instruments Ltd
Bartles Industrial Estate
North Street
Redruth
Cornwall TR15 1HR
United Kingdom

t +(44) 1209 314608
f. +(44) 1209 314609
f2. +(44) 870 1600860
i. www.scitec.uk.com
e. scitec@scitec.uk.com





Lock-In Amplifiers

What Are They?

LOCK-IN AMPLIFIERS

Lock-in amplifiers are used to measure the amplitude and phase of signals buried in noise. They achieve this by acting as an extremely narrow bandpass filter which removes all the noise while allowing through the signal to be measured. The frequency of the signal to be measured and hence the pass band region of the filter, is set by a reference signal which has to be supplied to the lock-in amplifier.

Lock-In Amplifiers Internal Workings

A basic lock-in amplifier can be split into 4 stages. An input gain stage, the reference circuit, a demodulator and a low pass filter. I will consider each section in turn.

Input Gain Stage

The variable gain input stage pre-processes the signal by amplifying it to a level suitable for the demodulator. Nothing complicated but high performance amplifiers are required.

Reference Circuit

The reference circuit allows the reference signal to be phase shifted.

Demodulator

The demodulator is just a multiplier. It takes the input signal and the reference and multiplies them together. When you multiply two sine waves together you get the sum and difference frequencies as the result. As the input signal to be measured and the reference signal are of the same frequency, the difference frequency is zero and you get a DC output which is proportional to the amplitude of the input signal and the cosine of the phase difference between the signals. By adjusting the phase of the reference signal using the reference circuit, the phase difference between the input signal and the reference can be brought to zero. At that point the DC output level from the multiplier is proportional to the input signal. The noise signals will still be present at the output of the demodulator and may have amplitudes 1000x larger than the DC offset.

Low Pass Filter

As the various noise components on the input signal are at different frequencies to the reference signal, the sum and difference frequencies will be non zero and will not contribute to the DC level of the output signal. This DC level (which is proportional to the input signal) can now be recovered by passing the output from the demodulator through a low pass filter.

We hope the above gives you an idea on how a basic Lock-In Amplifier works. Actual lock-in amplifiers are more complicated as there are instrument offsets that need to be removed, but the basic principle of operation is the same.





Noise In Lock-In Amplifiers

NOISE IN LOCK INS

There is no standard definition for lock-in amplifiers as to how to measure the input noise figure. This makes nonsense of other manufacturers figures and certainly makes comparisons difficult. Many of Scitec's competitors simply put the noise figure of their input stage op-amp down on their data sheets. This is easy to do but is incorrect as it is only valid for very high gains (x100000) and is not applicable for the lower first stage gains that are typically used (x10).

Taking actual measurements is difficult as well. Where should you take the measurement? after the first op-amp? (which will have a different gain from instrument to instrument) after the input gain stage? (if so at what gain setting?) or at the output of the instrument (which has far more noise sources than just the input).

Finally, we know some of competitors' figures are nonsense (or at the very least misleading) due to the circuits they use. Most lock-in's have AC coupled input which is produced by a simple RC filter. The resistor used is typically very high so as not to affect the input from a high impedance source and may have a value of 100M ohms. If you calculate the noise generated from this resistor you find it produces thermal noise of $1.27 \mu\text{V} / \text{Hz}^{1/2}$. This is a couple of orders of magnitude larger than then figure specified in the data sheets we are criticizing. The Scitec 400 series of lock-in's gets around this problem by DC coupling the input stage and does not use any resistors larger than 470k ohms.

Unfortunately, none of the above helps the customer make a comparison between Scitec and competitors regarding noise figures. We are not in a position to be able to test our competitors units so can not state that we are better or worse than they are. We can only say that the figures they give at best require a good deal of justification as to how they were produced.



Noise	been tested for electrostatic discharge damage. Scitec Instruments no longer specify input noise values as this leads to comparison with other manufacturers data sheets which are clearly grossly in error. If you wish for details of these values then please contact us and we will explain the situation.
Gain Accuracy	1%
Gain Stability	200ppm/°C
Dynamic Reserve	60dB

DEMODULATOR

The output of the signal input stage is processed using a very high bandwidth demodulator to recover the input signal. Offsets introduced at this stage are automatically removed via novel feedback mechanisms.

LOW PASS FILTER

The output from the demodulator is passed through a first order low pass filter and then amplified before output via a front panel BNC.

Time Constant	100µS to 30s in 1, 3, 10 steps
Output	±1V output corresponds to full scale Input. Short circuit protection included.
Offset	Up to 1x full scale, switchable on or off

REFERENCE CHANNEL

The reference input circuitry uses a phase locked loop to lock on to a range of signals, such as TTL pulses or sinusoidal waveforms. A phase shifting circuit allows the reference signal to be moved with relation to the signal input. signals at both the reference frequency and twice the reference frequency can be monitored.

Frequency	10Hz to 100kHz
Input Impedance	5.6MΩ ac coupled
Trigger	
Sine	100mV rms min (15V max.)
Pulse	5V, 95% mark/space ratio min.
Acquisition time	10s max.
Phase control	90° steps + fine shift in range 0° - 100°
Phase Drift	0.1°/°C

GENERAL

Power	115Vac, 230Vac; 50-60Hz; 10VA max.
Mechanical	440mm W x 87mm H x 190mm D (17½in x 3½in x 7½in)
Temperature range	0-50°C (operational)
Warranty	2 years from date of shipment

STANDARDS

Electrostatic Discharge	BS EN 61000-4-2 Level 2
Surge	BS EN 61000-4-5 Level 3
Burst & Transient	BS EN 61000-4-4 Level 2
RF Emissions	BS EN 50081-2
RF Immunity	BS EN 61000-4-3 / BS EN 50082-2
Low Voltage Directive	BS EN 61010-1





Model 420 Dual Phase Lock-In Amplifier

Scitec Instruments' Model 420 analogue dual phase lock-in amplifier uses advanced technology to provide a high performance instrument which is both versatile and easy to use.

- Dual phase operation with modulus (R) calculation
- Differential or single-ended input
- Gain settings from 3 μ V to 1V
- High performance wide bandwidth input gain stage
- Analogue meter for display of X, Y or R output signals
- Separate X, Y and R output BNCs
- X & Y Offset controls
- Output time constants from 100 μ s to 30s
- 1F and 2F reference signal operation
- 90° step and fine phase control

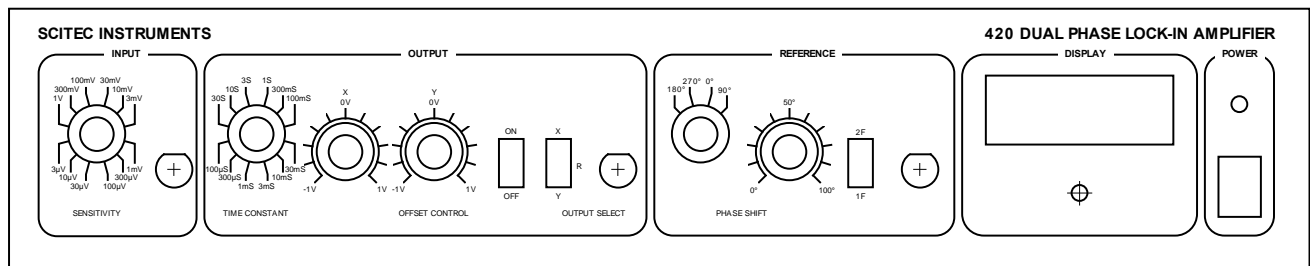

INPUT SIGNAL CHANNEL

The input signal channel amplifies the input signal to a level suitable for the demodulator. High performance, low-noise, broad-band amplifiers are used throughout. The input circuit can accept a differential or single-ended input via the front panel signal input BNC. Jumper options within the unit allow the outer BNC contact or screen to act as a high impedance differential input, as a low impedance (100 Ω) differential input or allow it to be connected to ground for single-ended operation.

The input channel can be either AC or DC coupled via internal jumper selection. It is recommended that the unit is used in DC coupled mode as the noise performance is improved. In this mode, through the careful design of the lock-in, up to ± 10 V of DC offset is allowed before saturation for gain settings from 1V to 300 μ V, ± 1 V of DC offset for gain settings from 100 μ V to 10 μ V and ± 300 mV of DC offset for the gain setting of 3 μ V.

Input	High or low impedance differential or single ended via front panel BNC
Sensitivity	3 μ V to 1V (for 1V output) switched in 1, 3, 10 steps
Input Impedance	10 ¹² Ω 1nF, dc coupled
Frequency	10Hz to 100kHz
Maximum Inputs	± 16 V before input protection circuitry comes into operation. The input BNC has



Noise	been tested for electrostatic discharge damage. Scitec Instruments no longer specify input noise values as this leads to comparison with other manufacturers data sheets which are clearly grossly in error. If you wish for details of these values then please contact us and we will explain the situation.
Gain Accuracy	1%
Gain Stability	200ppm/°C
Dynamic Reserve	60dB

DEMODULATOR

The output of the signal input stage is processed using two very high bandwidth demodulators each operating 90° apart from each other to produce the X and Y signals. Offsets introduced at this stage are automatically removed via novel feedback mechanisms.

LOW PASS FILTER

The X and Y outputs from the demodulator are passed through two first order low pass filters and then amplified. The X and Y signals are combined to produce R the modulus signal, where $R = \sqrt{(x^2 + y^2)}$, before output via a front panel BNC.

Time Constant	100µS to 30s in 1, 3, 10 steps
All Outputs	±1V output corresponds to full scale Input. Short circuit protection included.
Front Panel Output	X, Y or R switchable output
Rear Panel Outputs	X, Y and R separate outputs
Offset	Up to 1x full scale for both X and Y channels, switchable on or off

REFERENCE CHANNEL

The reference input circuitry uses a phase locked loop to lock on to a range of signals, such as TTL pulses or sinusoidal waveforms. A phase shifting circuit allows the reference signal to be moved with relation to the signal input. Signals at both the reference frequency and twice the reference frequency can be monitored.

Frequency	10Hz to 100kHz
Input Impedance	5.6MΩ ac coupled
Trigger	
Sine	100mV rms min (15V max.)
Pulse	5V, 95% mark/space ratio min.
Acquisition time	10s max.
Phase control	90° steps + fine shift in range 0° - 100°
Phase Drift	0.1°/°C

GENERAL

Power	115Vac, 230Vac; 50-60Hz; 10VA max.
Mechanical	440mm W x 87mm H x 190mm D (17½in x 3½in x 7½in)
Temperature range	0-50°C (operational)
Warranty	2 years from date of shipment

STANDARDS

Electrostatic Discharge	BS EN 61000-4-2 Level 2
Surge	BS EN 61000-4-5 Level 3
Burst & Transient	BS EN 61000-4-4 Level 2
RF Emissions	BS EN 50081-2
RF Immunity	BS EN 61000-4-3 / BS EN 50082-2
Low Voltage Directive	BS EN 61010-1



Boston Electronics Corporation, 91 Boylston Street, Brookline MA 02445

(800)347-5445 or (617)566-3821 * fax (617)731-0935 * boselec@boselec.com * www.boselec.com



Model 430 OEM Single Phase Lock-In Amplifier

Scitec Instruments' Model 430 OEM analogue lock-in amplifier uses advanced technology to provide a versatile high performance instrument.

- Single channel single phase operation
- Differential, single-ended or current input
- Gain settings from $3\mu\text{V}$ to 10V
- High performance wide bandwidth input gain stage
- Low pass filter output time constants from $100\mu\text{s}$ to 30s
- 1F and 2F reference signal operation
- 90° step and fine phase control

Input Modes: Differential, Single Ended, Current

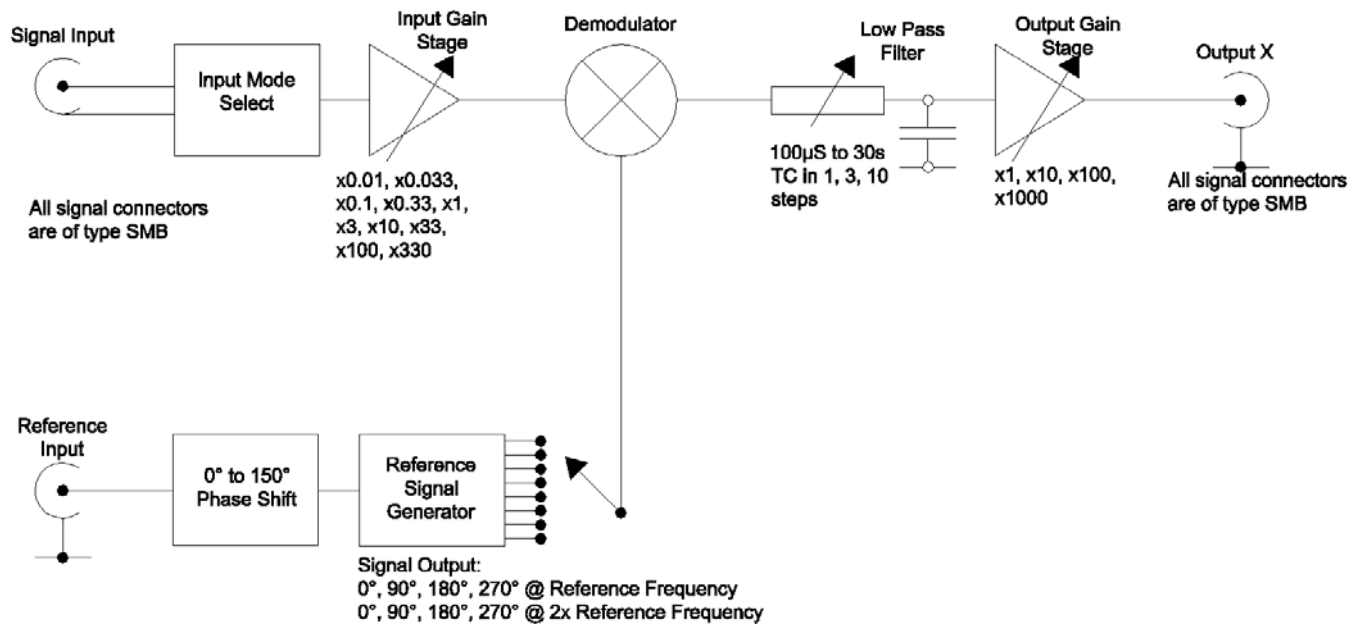
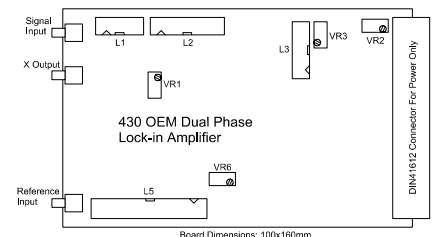

INPUT SIGNAL CHANNELS

The input signal channel amplifies the input signal to a level suitable for the demodulator. High performance, low-noise, broad-band amplifiers are used throughout.

The input circuits can accept differential or single-ended inputs via the input BNC connectors. Jumper options within the unit allow the outer SMB contact or screen to act as a high impedance differential input or allow it to be connected to ground for single-ended operation. The 430 lock-in will also accept current inputs through the development of a voltage across a resistor. This mode is not guaranteed by Scitec.



The input channels are DC coupled rather than the more normal AC coupling seen on other lock-in amplifiers as the noise performance is improved.

Input	Differential or single ended voltage or current input via SMB socket
Sensitivity	3 μ V to 10V in 1, 3, 10 steps. The input gain is set using jumpers enabling simple gain changes. One set of gain resistors are mounted on solder pillars so that they can be easily changed by the user with the aid of a soldering iron.
Input Impedance	10 ¹² Ω 1nF, dc coupled
Frequency	10Hz to 100kHz
Maximum Inputs	\pm 10V before saturation occurs.
Noise	Scitec Instruments no longer specifies input noise values as this leads to comparison with other manufacturers data sheets which are clearly grossly in error. If you wish for details of these values then please contact us and we will explain the situation.
Gain Accuracy	1%
Gain Stability	200ppm/ $^{\circ}$ C
Dynamic Reserve	0dB to 80dB adjustable via jumpers.

DEMODULATOR

The input stage drives a high performance demodulator to recover the input signal.

OUTPUT

The demodulator output is passed through a low pass filter before being amplified for output.

Low Pass Filter Time Constant	100 μ S to 30s in 1, 3, 10 steps. The time constant is set using jumpers enabling simple time constant changes. One set of resistor capacitor values are mounted on solder pillars so that they can be easily modified with the aid of a soldering iron.
Outputs - SMB connectors	\pm 100mV to \pm 10V full scale output. Can be modified through jumper settings.

REFERENCE CHANNEL

The reference signal is used to generate the signals that drive the demodulator. A fine phase shifting circuit allows the reference signal to be phase shifted from 0 $^{\circ}$ to 150 $^{\circ}$ with relation to the signal input. A second circuit then produces signals that are phase shifted by 0 $^{\circ}$, 90 $^{\circ}$, 180 $^{\circ}$ and 270 $^{\circ}$ at both the reference frequency and twice the reference frequency. Any of these 8 signals can be used to drive the demodulator.

Frequency	10Hz to 100kHz
Trigger	Standard TTL, 95% mark/space ratio min. Rising edge triggered.
Acquisition time	10s max.
Phase control	90 $^{\circ}$ steps + fine shift in range 0 $^{\circ}$ - 150 $^{\circ}$
Phase Drift	0.1 $^{\circ}$ / $^{\circ}$ C
1F and 2F operation	

GENERAL

Power	-15V, 0V, +5V, +15V DC @ 35mA per supply. Power connections are made via 64 pin type C DIN41612 connector. Signal connections are not possible via this connector.
Mechanical	100 x 160mm
Temperature range	0-50 $^{\circ}$ C (operational)
Warranty	2 years from date of shipment



SPECIFICATIONS, Model 432 digital control lock in

Input Stage

Input Signal Modes: Single Ended or Fully Differential, AC or DC coupled.

Input Gain: x1, x3.3, x10, x33, x100, x330, x1000

Analogue Connections: SMB connectors

Input Impedance: 10^{12} Ohms || 1nF, dc coupled

Maximum Inputs: ± 12 V DC before saturation occurs.

Gain Accuracy: 1%

Gain Stability: 200ppm/ $^{\circ}$ C

Frequency: 10Hz to 100kHz

Output Stage

Output Gain: x1, x10, x100, x1000 (Equivalent to Dynamic Reserves of 0dB, 20dB, 40dB and 80dB respectively)

Time Constant Settings: 100 μ s, 330 μ s, 1ms, 3.3ms, 10ms, 33ms, 100ms, 330ms, 1s, 3.3s, 10s, 33s

Output Offset Trim: ± 1 V in 256 steps

Reference Stage

Frequency: 10Hz to 100kHz

Signal Types: Standard TTL or CMOS with mark to space ratio from 1:10 to 10:1. Rising edges only used by the instrument. Sine, triangular, square waves, etc. with amplitudes from 200mV to 10V rms.

Fine Phase Adjust: 0° to 150° in 256 steps

Coarse Phase Adjust: 0° , 90° , 180° & 270° @ reference frequency

0° , 90° , 180° & 270° @ 2 x reference frequency

Bypass: Both the coarse and fine phase circuitry can be bypassed using jumpers.

General

Size: 100x160mm - Standard Eurocard

Digital Connector: 64 pin type C DIN41612

30 pin IDC connector

Power: 55mA @ +15V, 0V, 40mA @ -15V

The device will also operate from ± 12 V but with reduced headroom

Computer Interface: 8 bit interface with Chip Select and Write signals.

All settings are undefined at power up.



Model 441

OEM Dual Phase Lock-In Amplifier

Scitec Instruments' Model 441 OEM analogue lock-in amplifier uses advanced technology to provide a versatile high performance instrument.

- Dual phase operation
- Differential, single-ended or current input
- Gain settings from 3 μ V to 10V
- High performance wide bandwidth input gain stage
- Low pass filter output time constants from 100 μ s to 30s
- X, Y and R Outputs
- 1F and 2F reference signal operation
- 90° step and fine phase control

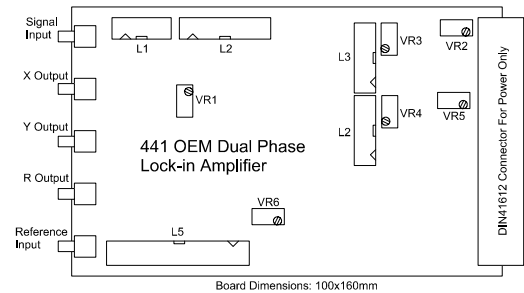

Input Modes: Differential, Single Ended, Current

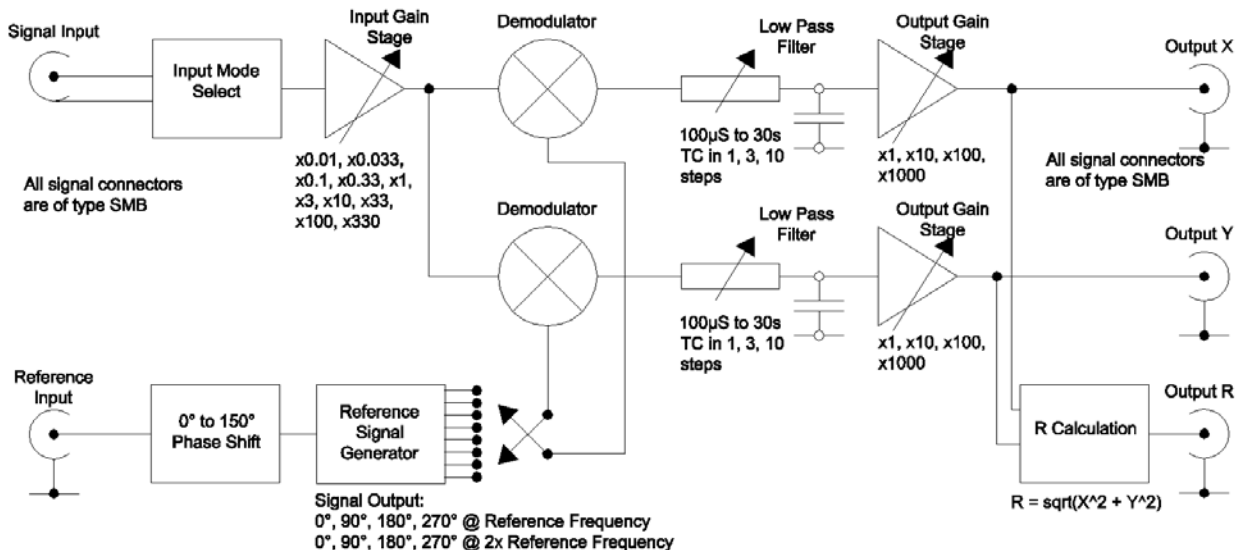

OPERATIONAL MODES

The 441 OEM analogue lock-in amplifier can operate in 2 main modes:

- Dual phase operation - 1 input signal with 2 demodulators operating at 90° apart providing the X and Y or real and imaginary parts of the input signal.
- Single channel 1F and 2F operation - 1 input signal and 2 demodulators operating at 1x and 2x the reference frequency to measure the first and second harmonic of the input signal.

INPUT SIGNAL CHANNELS

The input signal channel amplifies the input signals to a level suitable for the demodulator. High performance, low-noise, broad-band amplifiers are used throughout.

The input circuit can accept differential or single-ended inputs via the input SMB connectors. Jumper options within the unit allow the outer SMB contact or screen to act as a high impedance differential input or allow it to be connected to ground for single-ended operation. The 441 lock-in will also accept current inputs through the development of a voltage across a precision resistor. This mode is not guaranteed by Scitec.



The input channels are DC coupled rather than the more normal AC coupling seen on other lock-in amplifiers as the noise performance is improved.

Input Sensitivity	Differential or single ended voltage or current input via SMB socket 3 μ V to 10V in 1, 3, 10 steps. The input gain is set using jumpers enabling simple gain changes. One set of gain resistors are mounted on solder pillars so that they can be easily changed by the user with the aid of a soldering iron.
Input Impedance	10 ¹² Ω 1nF, dc coupled
Frequency	10Hz to 100kHz
Maximum Inputs	\pm 10V before saturation occurs.
Noise	Scitec Instruments no longer specify input noise values as this leads to comparison with other manufacturers data sheets which are clearly grossly in error. If you wish for details of these values then please contact us and we will explain the situation.
Gain Accuracy	1%
Gain Stability	200ppm/ $^{\circ}$ C
Dynamic Reserve	0dB to 80dB adjustable via jumpers.

DEMODULATOR

The input stage drives two high bandwidth demodulators to recover the input signal.

OUTPUT

The demodulator outputs are passed through low pass filters before being amplified for output.

Low Pass Filter Time Constant	100 μ S to 30s in 1, 3, 10 steps. The time constant is set using jumpers enabling simple time constant changes. One set of resistor capacitor values are mounted on solder pillars so that they can be easily modified with the aid of a soldering iron.
Outputs - SMB connectors	\pm 100mV to \pm 10V full scale output. Can be modified through jumper settings.
R Calculation	The modulus of the two output signals is produced, where $R = \sqrt{X^2 + Y^2}$.

REFERENCE CHANNEL

A single reference signal is used to generate the signals that drive both demodulators.

A fine phase shifting circuit allows the reference signal to be phase shifted from 0 $^{\circ}$ to 150 $^{\circ}$ with relation to the signal input. A second circuit then produces signals that are phase shifted by 0 $^{\circ}$, 90 $^{\circ}$, 180 $^{\circ}$ and 270 $^{\circ}$ at both the reference frequency and twice the reference frequency. Any of these 8 signals can be used to drive either demodulator through the positioning of a set of jumpers.

Frequency	10Hz to 100kHz
Trigger	Standard TTL, 95% mark/space ratio min. Rising edge triggered.
Acquisition time	10s max.
Phase control	90 $^{\circ}$ steps + fine shift in range 0 $^{\circ}$ - 150 $^{\circ}$
Phase Drift	0.1 $^{\circ}$ / $^{\circ}$ C
1F and 2F operation	

GENERAL

Power	-15V, 0V, +5V, +15V DC @ 50mA per supply. Power connections are made via 64 pin type C DIN41612 connector. Signal connections are not possible via this connector.
Mechanical	100 x 160mm
Temperature range	0-50 $^{\circ}$ C (operational)
Warranty	2 years from date of shipment





Scitec Instruments Ltd

Bartles Industrial Estate Tel: +44 (0)1209 314 608 scitec@scitec.uk.com
North Street, Redruth Fax: +44 (0)1209 314 609 www.scitec.uk.com
Cornwall TR15 1HR Fax2: +44 (0)870 1600 860

SPECIFICATIONS, Model 442 digital control lock in

Input Stage

Input Signal Modes: Single Ended or Fully Differential, AC or DC coupled.

Input Gain: x1, x3.3, x10, x33, x100, x330, x1000

Analogue Connections: SMB connectors

Input Impedance: 10^{12} Ohms || 1nF, dc coupled

Maximum Inputs: ± 12 V DC before saturation occurs.

Gain Accuracy: 1%

Gain Stability: 200ppm/ $^{\circ}$ C

Frequency: 10Hz to 100kHz

Output Stage

Outputs: X, Y and R

Output Gain: x1, x10, x100, x1000 (Equivalent to Dynamic Reserves of 0dB, 20dB, 40dB and 80dB respectively)

Time Constant Settings: 100 μ s, 330 μ s, 1ms, 3.3ms, 10ms, 33ms, 100ms, 330ms, 1s, 3.3s, 10s, 33s

Output Offset Trim: ± 1 V in 256 steps

Reference Stage

Frequency: 10Hz to 100kHz

Signal Types: Standard TTL or CMOS with mark to space ratio from 1:10 to 10:1. Rising edges only used by the instrument. Sine, triangular, square waves, etc. with amplitudes from 200mV to 10V rms.

Fine Phase Adjust: 0° to 150° in 256 steps

Coarse Phase Adjust: 0° , 90° , 180° & 270° @ reference frequency

0° , 90° , 180° & 270° @ 2 x reference frequency

Bypass: Both the coarse and fine phase circuitry can be bypassed using jumpers.

General

Size: 100x160mm - Standard Eurocard

Digital Connector: 64 pin type C DIN41612

34 pin IDC connector

Power: 75mA @ +15V, 0V, 60mA @ -15V

The device will also operate from ± 12 V but with reduced headroom

Computer Interface: 8 bit interface with Chip Select and Write signals.

All settings are undefined at power up.

The interface can be directly connected to the Parallel Port of a PC. DOS based software to control the lock-in amplifier board from the PC is included together with source code.



410, 420, 43x, 44x 10V Operation

Application Note Overview

A number of customers have required a +/- 10V output from the Scitec Instruments 4xx lock-in amplifiers. This application note gives details of how this can be achieved.

Standard Operation

During standard operation, the 4xx units will produce output voltages and meter readings as specified in the following table:

Standard Operation (60dB Dynamic Reserve)				
Gain Setting	Input Signal	Maximum Input Noise Signal Before Overload Occurs	Output Voltage*	Meter Reading*
1V	1V AC RMS	14V Peak	1V DC	Full Scale (+1)
300mV	300mV AC RMS	14V Peak		
100mV	100mV AC RMS	14V Peak		
30mV	30mV AC RMS	14V Peak		
10mV	10mV AC RMS	14V Peak		
3mV	3mV AC RMS	4.2V Peak		
1mV	1mV AC RMS	1.4V Peak		
300µV	300µV AC RMS	420mV Peak		
100µV	100µV AC RMS	140mV Peak		
30µV	30µV AC RMS	42mV Peak		
10µV	10µV AC RMS	14mV Peak		
3µV	3µV AC RMS	4.2mV Peak		

* Assumes input signal is in phase with reference.

An input signal of the same size as the gain setting will give full scale or 1V output. Signals smaller than the gain setting will give proportionately smaller outputs.

When operated as above, the unit has a dynamic reserve of 60dB.

Overdriving the Input to Give +/-10V Output

A 10V output signal can be produced by reducing the gain setting by a factor of 10. No modifications to the 4xx are required to do this.

Overdriving the input by a factor of 10 (40dB Dynamic Reserve)				
Gain Setting	Input Signal	Maximum Input Noise Signal Before Overload Occurs	Output Voltage*	Meter Reading*
1V	10V AC RMS	14V Peak	+10V DC	OVERLOAD
300mV	3V AC RMS	14V Peak		
100mV	1V AC RMS	14V Peak		
30mV	300mV AC RMS	14V Peak		



10mV	100mV AC RMS	14V Peak		
3mV	30mV AC RMS	4.2V Peak		
1mV	10mV AC RMS	1.4V Peak		
300µV	3mV AC RMS	420mV Peak		
100µV	1mV AC RMS	140mV Peak		
30µV	300µV AC RMS	42mV Peak		
10µV	100µV AC RMS	14mV Peak		
3µV	30µV AC RMS	4.2mV Peak		

* Assumes input signal is in phase with reference

This method of operation has a number of disadvantages which need to be noted:

- The dynamic reserve of the system is reduced to 40dB
- The meter reading is off scale. This will not harm the meter as the 410 and 420 instruments have meter protection circuitry built into them.

Factory Modification to Give +/-10V Output

The internal circuitry of the 410 or the 420 can be modified at the factory to give a +/-10V Output.

Standard Operation (60dB Dynamic Reserve)				
Gain Setting	Input Signal	Maximum Input Noise Signal Before Overload Occurs	Output Voltage*	Meter Reading*
1V	1V AC RMS	14V Peak	10V DC	Full Scale (+10)
300mV	300mV AC RMS	14V Peak		
100mV	100mV AC RMS	14V Peak		
30mV	30mV AC RMS	14V Peak		
10mV	10mV AC RMS	14V Peak		
3mV	3mV AC RMS	4.2V Peak		
1mV	1mV AC RMS	1.4V Peak		
300µV	300µV AC RMS	420mV Peak		
100µV	100µV AC RMS	140mV Peak		
30µV	30µV AC RMS	42mV Peak		
10µV	10µV AC RMS	14mV Peak		
3µV	3µV AC RMS	4.2mV Peak		

* Assumes input signal is in phase with reference.

There is no charge for making this modification if specified at any time before delivery.

Care must be taken with these units that the time constant used on the output is sufficiently large to keep the output signal below about 12V DC. If the output has an average level of 10V but has a noise level of say +/-5V then the signal above 12V DC will be removed, causing the average output level to be lowered. This will cause the meter to read low.

If you currently own a 410 or 420 instrument and wish to modify the unit yourself, then please contact Scitec for details.

